

WOODEN CITY®

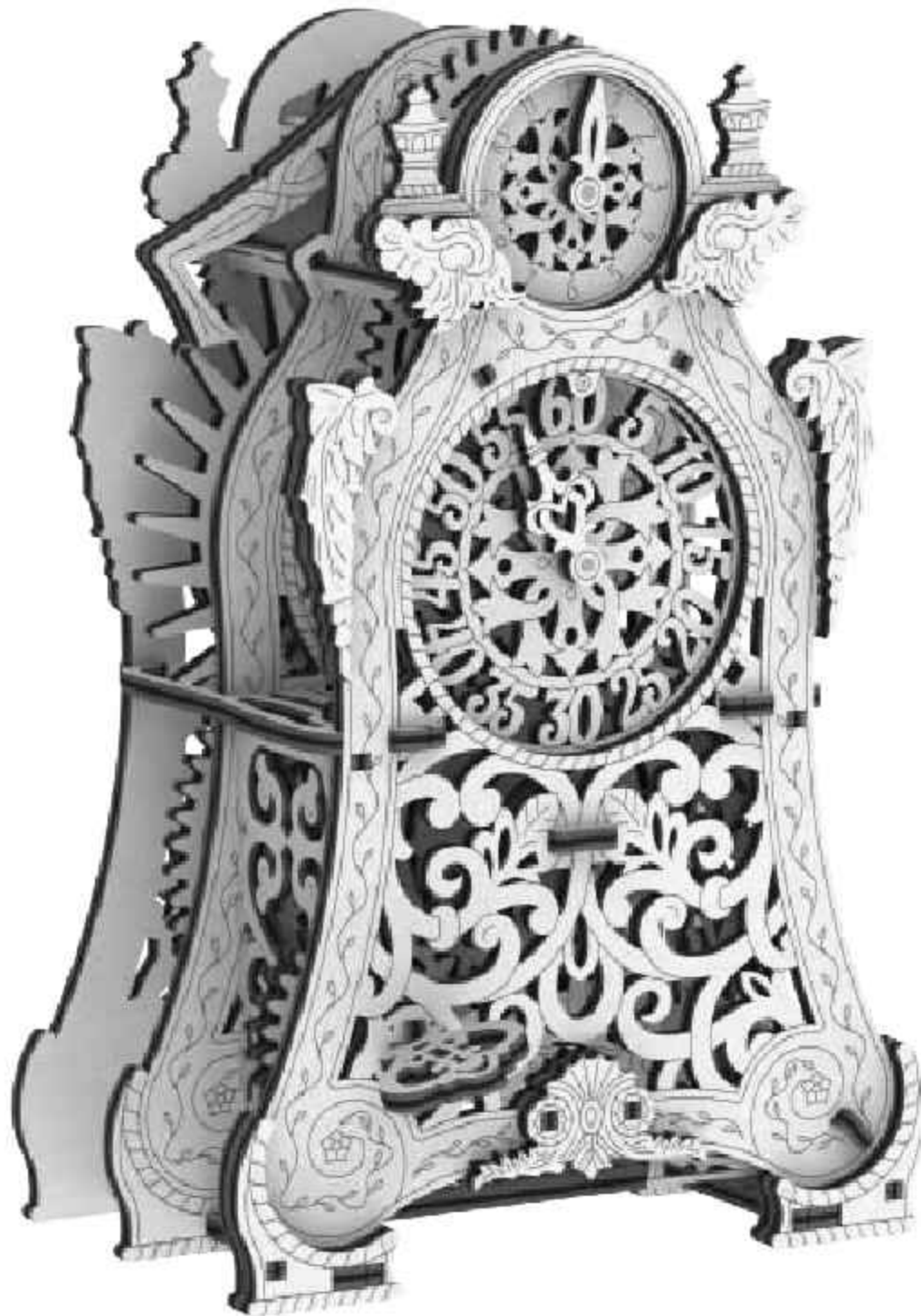

Magic clock  
Assembly instruction

**EN**

Assembly instruction.

Package contains:

1. 140 parts on 3 ply sheets
2. 9 spare parts
3. Rubber bands
4. Axles (large and small)
5. Ruler (for checking dimensions)

You will need: razor blade, scissors, sandpaper and wax candle. Very carefully push out the pieces from the front side of the board, taking care not to break them. If the piece does not come out, gently cut the notches with the razor blade. This model does not require glue or paint. To reduce friction, the gear face and the axle rotation areas should be waxed. Assemble in a well-lit area and follow the instructions carefully. You can also disassemble this model in reverse order.

**ES**

Instrucción de montaje.

El paquete contiene:

1. 140 partes fijadas en las 3 hojas de la madera contrachapada
2. 9 piezas de repuesto
3. Gomas elásticas
4. Ejes (grandes y pequeños)
5. Regla para comprobar las dimensiones

Para el montaje necesitará: cuchillo de papelería, tijeras, papel de lija y una vela. Con mucho cuidado exprimirá los detalles desde el anverso de la tabla, tratando de no romperlos. Si, el detalle no sale, corte suavemente los puentes con el cuchillo estacionario. Este modelo se monta sin pegamento y no requiere la pintura. Para evitar el agarrotamiento y para reducir la fricción, la cara del engranaje y las áreas de rotación del eje deben encerarse. Es recomendable montar el modelo con buena iluminación y seguir estrictamente las instrucciones. También puede desmontar este modelo en orden inverso.

**FR**

Instruction de montage.

Composant modèle:

1. 140 pièces sur 3 panneau
2. 9 pièces de rechange
3. Des élastiques
4. Axe épais et mince
5. Il possède une règle pour vérifier les dimensions

Pour l'assemblage, vous auriez besoin: du couteau de papeterie, des ciseaux, du papier de verre et d'une bougie de cire. Il faut enlever les détails tout doucement du côté avant de la feuille, de soi, de façon qu'ils ne soient pas endommagés. Si l'article ne peut pas être retiré, coupez-le avec le couteau de papeterie. Le montage du modèle se fait sans colle et ne nécessite pas de peinture. Pour éviter les blocages et pour une meilleur glissement du mécanisme, il faut graisser les extrémités des engrenages et l'axe dans les zones de rotation avec la bougie de cire. Il est recommandé de monter le modèle ayant une bonne illumination et strictement selon les instructions. Vous pouvez également démonter ce modèle dans l'ordre inverse.

**PL**

Instrukcja składania

Zestaw zawiera:

1. 140 detali umieszczonych na 3 arkuszach sklejk
2. 9 części zapasowych
3. Gumki
4. Osie grube i cienkie
5. Linijka do sprawdzania wymiarów

Do złożenia modelu niezbędne będą: nóż techniczny, nożyczki, papier ścierny oraz świeca woskowa. Detale wypycha się delikatnie od prawej strony arkusza uważając, aby ich nie uszkodzić. Jeżeli wystąpi trudność z wyciśnięciem pożądanego elementu, wówczas należy go delikatnie naciąć nożykiem z lewej strony arkusza. Powinno się wypychać z arkusza tylko te elementy nad którymi aktualnie się pracuje, w przeciwnym razie mogą się pogubić. Model należy składać przy dobrze doświetlonym stanowisku zgodnie z instrukcją. Model można rozłożyć w odwrotnej kolejności. Model składa się bez użycia kleju. W celu prawidłowego funkcjonowania mechanizmu, należy osie i koła zębate natrzeć świecą woskową.

**DE**

Aufbauanleitung.  
Im Set enthalten:

1. 140 Teile in 3 Platten
2. 9 Ersatzteile
3. Gummibänder
4. Achsen dick und dünn
5. Lineal zur Kontrolle

Fürs Zusammenbauen benötigen Sie: Messer, Schere, Schleifpapier und eine Kerze. Die Einzelteile werden von der Oberseite nach unten ausgedrückt. Wenn sich ein Teil nicht herausnehmen lässt, schneiden Sie die Haltestege mit dem Messer leicht ein Um ein Steckenbleiben vorzubeugen, schmieren Sie die Achsen und Zahnräder etwas mit dem Kerzenwachs ein. Dieses Modell ist ohne Kleber montiert und erfordert keine Lackierung. Sie beim Zusammenbau für eine gute Beleuchtung und setzen die Einzelteile strikt nach der Anleitung zusammen. Modell kann auch wieder auseinandergebaut werden.

**CN**

裝配說明。

每盒模型包括：

- 1、3片樺木板, 合共140件零件
- 2、9件備用零件
- 3、橡筋圈
- 4、粗幼輪軸兩款
- 5、輔助測量尺

您會用到：美工刀、剪刀、砂紙、干蠟燭。請小心翼翼並從正對着板材的方向將零件推出，注意不要折斷。如果零件無法推出，可以用美工刀小心地輔助。此模型無需用到膠水和油漆。為防止交合和過大的摩擦，齒輪表面以及轉動軸的區域可以擦上干蠟。請在照明充足的情況下進行裝配並且積極遵循說明書。也可以通過逆向順序對模型進行拆解。

**RU**

Инструкция по сборке.  
Комплектация модели:

1. 140 деталей, расположенных на 3 листах фанеры
2. 9 запасных деталей
3. Резинки канцелярские
4. Оси толстые и тонкие
5. Линейка для проверки размеров

Для сборки Вам понадобится: канцелярский нож, ножницы, наждачная бумага и восковая свеча. Выдавливать детали нужно аккуратно с лицевой стороны листа от себя, чтобы их не повредить. Если деталь не вынимается, надрежьте перемычки канцелярским ножом. Модель собирается без клея и не требует покраски. Для предотвращения заклинивания и наилучшего скольжения механизма, необходимо торец шестерни и оси в местах вращения смазать восковой свечой. Собирать модель рекомендуется при хорошем освещении и строго по инструкции. Разбирать можно в обратной последовательности.

**IT**

Istruzioni di montaggio.

La scatola contiene:

1. 140 pezzi situati sui 3 fogli
2. 9 pezzi di ricambio
3. Elastici
4. Asse sottile e spessa
5. La linea e/o dima per controllare le dimensioni

Il necessario per costruire: coltello di cancelleria, forbici, carta vetrata e cera di candela. Premere delicatamente sui pezzi pretagliati, dalla parte anteriore del foglio, per non rovinarli. Se il singolo pezzo non può essere rimosso, fate piccoli tagli con un taglierino da cancelleria. Il modello si monta senza colla e non ha bisogno di essere pitturato. Per evitare inceppamenti e migliorare lo scivolamento dei meccanismi, attrezzarsi di un prodotto lubrificante tipo cera di candela. Si consiglia di montare il modello con la luce adeguata e seguendo le istruzioni. Lo smontaggio dello stesso può avvenire con le dovute precauzioni. Smontare il modello possibile in ordine inverso.

**EN** Notations **FR** Désignation symbollique **ES** Notas  
**PL** Oznaczenia umowne **DE** Symbolbezeichnung **RU** Условные обозначения  
**IT** Simboli **CN** 符号示意



**EN** Approximate assembly time.  
**FR** Temps d'assemblage estimé.  
**ES** Tiempo estimado de construcción.  
**PL** Przybliżony czas składnia.  
**DE** Aufbauzeit.  
**RU** Примерное время сборки.  
**IT** Tempo di costruzione stimato.  
**CN** 预估组装时间



**EN** Check orientation of each piece before connecting.  
**FR** Vérifiez l'emplacement des éléments.  
**ES** Comprobar la posición de los elementos.  
**PL** Uwaga! Sprawdź rozmieszczenie elementów.  
**DE** Prüfen Sie die Positionen der Elemente.  
**RU** Проверьте расположение элементов.  
**IT** Controllare le posizioni degli elementi.  
**CN** 检查零件位置



**EN** Check the measurements with the ruler.  
**FR** Vérifiez les dimensions.  
**ES** Comprobar los tamaños.  
**PL** Sprawdź rozmiar.  
**DE** Prüfen Sie die Abmessungen.  
**RU** Проверьте размеры.  
**IT** Controllare le dimensioni.  
**CN** 检查零件尺寸



**EN** Press each piece all the way up to the stop.  
**FR** Appuyez au maximum.  
**ES** Presione hasta el tope.  
**PL** Wciśnij do oporu.  
**DE** Bis zum Anschlag zusammendrücken.  
**RU** Прижмите до упора.  
**IT** Premere per interrompere.  
**CN** 向上压紧直至到位



**EN** Use wax.  
**FR** Lubrifiez les pièces avec la bougie.  
**ES** Cera los detalles.  
**PL** Natrzyj element świecą woskową.  
**DE** Mit Kerzenwachs einschmieren.  
**RU** Смажьте детали свечой.  
**IT** Candela per Lubrificare le parti.  
**CN** 给零件上干蜡



**EN** Remember spare pieces are included.  
**FR** Pièces de rechange.  
**ES** Detalles de repuesto.  
**PL** Części zamienné.  
**DE** Ersatzteile.  
**RU** Запасные детали.  
**IT** Pezzi di ricambio.  
**CN** 备用零件



**EN** Cut off with a knife.  
**FR** Coupez avec le couteau.  
**ES** Cortar con el cuchillo.  
**PL** Odetniij nożem.  
**DE** Abschneiden.  
**RU** Отрежьте ножом.  
**IT** Tagliarino.  
**CN** 用美工刀切断



**EN** Carefully move apart.  
**FR** Faites séparer délicatement.  
**ES** Separar cuidadosamente.  
**PL** Delikatnie rozsunąć detale.  
**DE** Vorsichtig auseinanderschieben.  
**RU** Аккуратно раздвиньте.  
**IT** Far scorrere delicatamente.  
**CN** 分离时多加小心



**EN** Use sandpaper or razor blade to smooth notches on each piece.  
**FR** Les bavures après les coupures doivent être ponçées légèrement avec du papier de verre fin ou coupées soigneusement avec un couteau de papeterie.  
**ES** Las rebabas en el puente deben ser amoladas suavemente con el papel esmeril o cortadas cuidadosamente con el cuchillo estacionario.  
**PL** Uwaga: pozostałości po zaczepach technicznych na detalach można usunąć drobnoziarnistym papierem ściernym lub nożem technicznym.  
**DE** Eventuell verbleibende Haltereste mit Messer oder Schleifpapier entfernen. Das Modell wird ohne Kiebel zusammengesetzt.  
**RU** Заусенцы от перемычек следует отшлифовать легкими движениями мелкой наждачной бумагой или аккуратно срезать канцелярским ножом.  
**IT** Le barbe dei ponticelli devono essere levigate leggermente con la sottile carta vetrata o tagliati con cautela con coltello di cancelleria.  
**CN** 推出后的零件边缘可能会有毛刺，请用砂纸去除，也可以用美工刀小心切除。



**EN** The part numbers that are included in this node.  
**FR** Les références sont incluses dans cette unité.  
**ES** Números de piezas que forman parte de la junta.  
**PL** Numery części, które wchodzą do składu danego węzła.  
**DE** Die Nummern der Elemente, die zu diesem Teil des Modells gehören.  
**RU** Номера деталей которые входят в этот узел.  
**IT** Numero di pezzi per questo nodo.  
**CN** 此信息已包括所需要组件编号

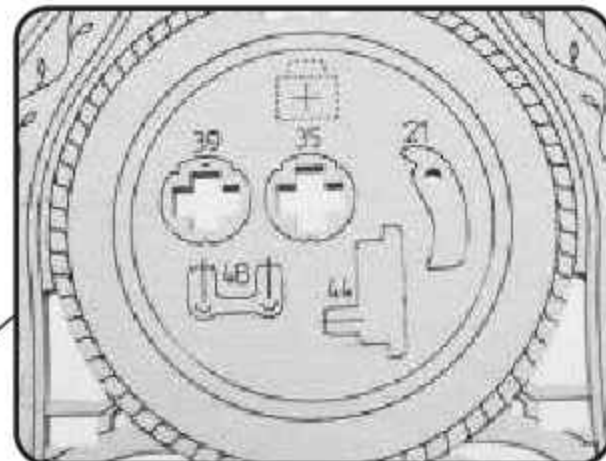
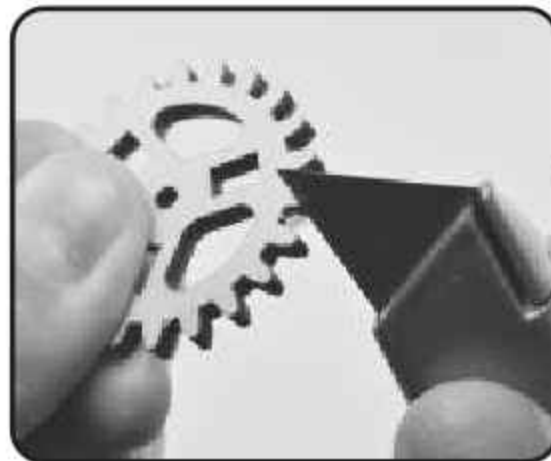
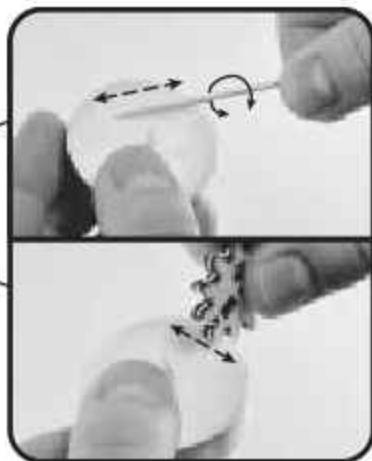



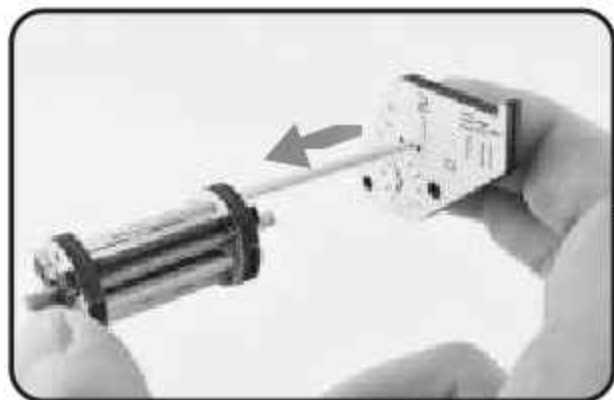

**EN** The ruler is used for size check. **FR** La règle pour vérifier les dimensions. **ES** La escala para la verificación de tamaño. **PL** Linijka do sprawdzenia wymiarów. **DE** Lineal um diverse Abmessungen zu prüfen. **RU** Линейка для проверки размеров. **IT** La linea per controllare le dimensioni. **CN** 辅助测量尺

**EN** These holes help to push thin axles through several of the pieces. **FR** Les ouvertures indiquées vous aideront à pousser l'axe fin à travers quelques détails. **ES** Estos agujeros ayudan a empujar el eje delgado a través de varios detalles sobre ejes. **PL** Otwory w linijce mogą być pomocne przy przeciskaniu patyczków (osi) przez kilka elementów. **DE** Die angegebenen Öffnungen helfen Ihnen, eine dünne Achse durch mehrere Öffnungen zu schieben. **RU** Указанные отверстия помогут протолкнуть тонкую ось через несколько деталей. **IT** Questi piccoli fori aiuteranno a spingere ed inserire l'asse attraverso le piccole parti. **CN** 小孔是用于帮助细轴穿过不同零件而设计的。

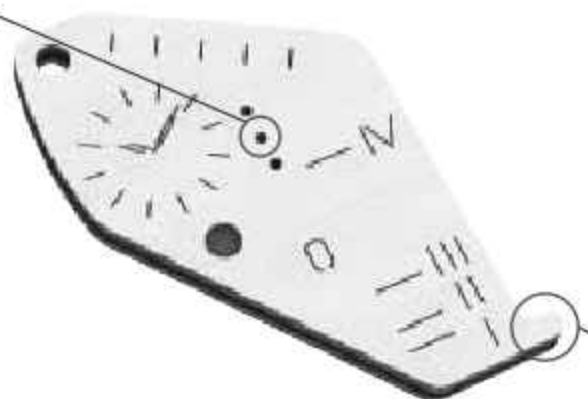

**EN** Large rubber piece.  
**FR** Grande pièce en caoutchouc.  
**ES** Banda de caucho grande.  
**PL** Duża gumka.  
**DE** Dickes Gummiband.  
**RU** Большая резинка.  
**IT** Grande elastico.  
**CN** 大橡胶件

**EN** The yellow rubber band is for the rotation of the model mechanism. Install it as shown in the picture. **FR** L'élastique jaune est conçu pour faire tourner le mécanisme du modèle. Installez-le comme est indiqué sur le dessin. **ES** El caucho amarillo es para la rotación del mecanismo del modelo. Instálelo como se muestra en la imagen. **PL** Żółta gumka przeznaczona jest do napędu mechanizmu modelu. Zamontować ją należy zgodnie z instrukcją. **DE** Gelbes Gummiband dient dazu, den Mechanismus zu drehen. **RU** Желтая резинка предназначена для вращения механизма модели. Установите её как показано на рисунке. **IT** Elastico giallo serve per il movimento del meccanismo del modello. Installare come mostrato nel disegno. **CN** 黄色皮筋用于模型机构的旋转。请按图示进行安装

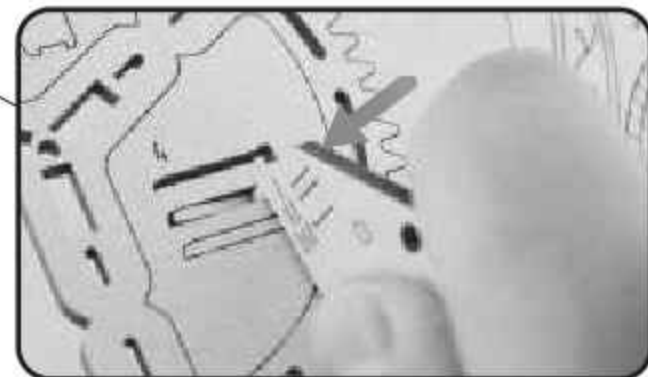
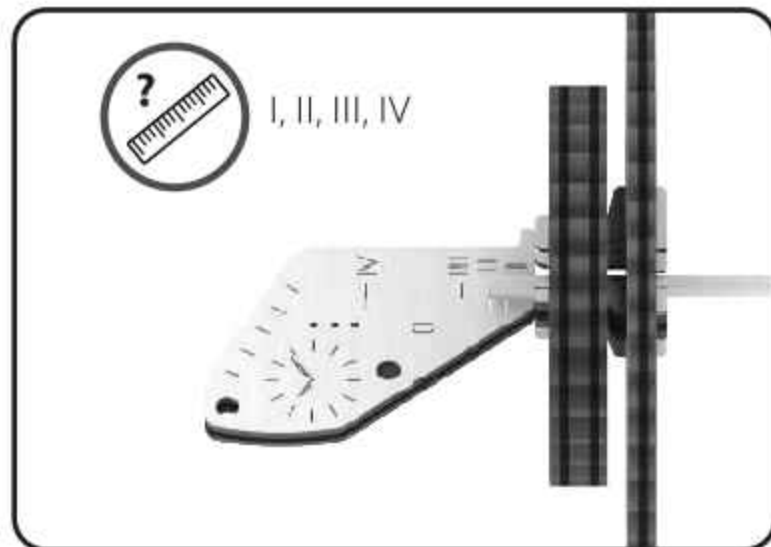

**EN** This tool is for pushing the small pieces out of the board. Also may be used for disassembly. **FR** La proéminence est conçue pour aider à presser et enlever les petits détails de la feuille. On peut l'utiliser aussi pour pousser les petites pièces lors du démontage du modèle. **ES** La repisa es para apretar los pequeños detalles fuera del tablero. Además, también puede empujar los pequeños detalles en el proceso de desmontaje. **PL** Występ w linijce przeznaczony jest do wyciskania małych detali z arkusza sklejki. Można go wykorzystać również przy rozkładaniu modelu. **DE** Der Vorsprung dient dazu, kleine Teile aus den Platten zu drücken. Er kann auch zum ausdrücken kleiner Teile beim Auseinanderbauen des Modells benutzt werden. **RU** Выступ предназначен для выдавливания из листа мелких деталей. Также им можно выталкивать мелкие детали при разборке модели. **IT** Le proiezioni riportate sui fogli di istruzioni sono utili anche nella fase di smontaggio per estrarre i pezzi. **CN** 推件器是用于将小零件从板材上推出。您可以遵照2张示意图中的拆解步骤将小零件推出。

**EN** Axles large and small **FR** Axe épais et mince **ES** Ejes grandes y pequeños **PL** Osie grube i cienkie  
**DE** Achsen in dick und dünn **RU** Оси толстые и тонкие **IT** Asse sottili e spessi **CN** 粗细轮轴两款

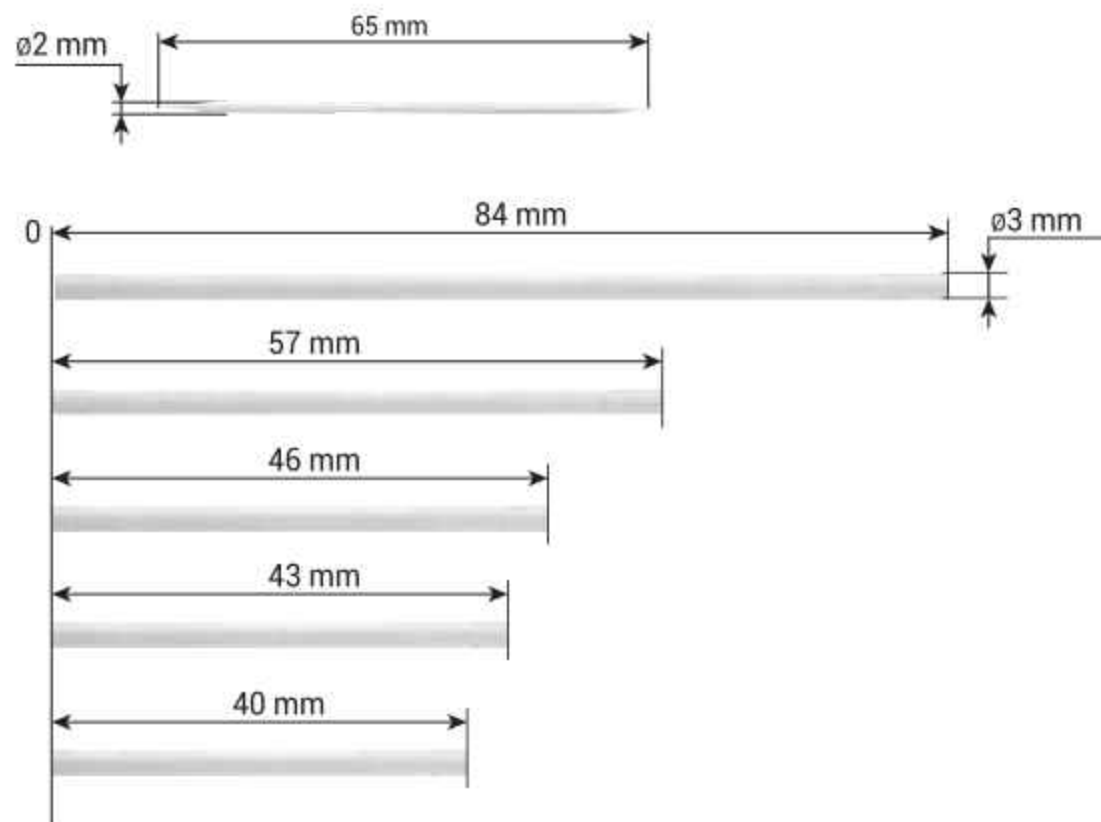

**EN** Small rubber piece.  
**FR** Petite pièce en caoutchouc.  
**ES** Banda de caucho pequeña.  
**PL** Mała gumka.  
**DE** Dünnes Gummiband.  
**RU** Малая резинка.  
**IT** Piccolo elastico.  
**CN** 小橡胶件

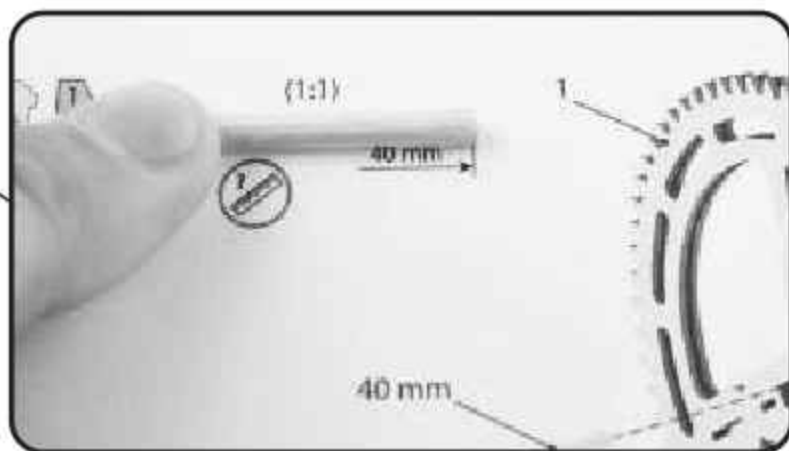

**EN** Check the measurements.  
**FR** Vérifiez les dimensions.  
**ES** Comprobar los tamaños.  
**PL** Sprawdź rozmiar.  
**DE** Prüfen Sie die Abmessungen.  
**RU** Проверьте размеры.  
**IT** Controllare le dimensioni.  
**CN** 检查零件尺寸

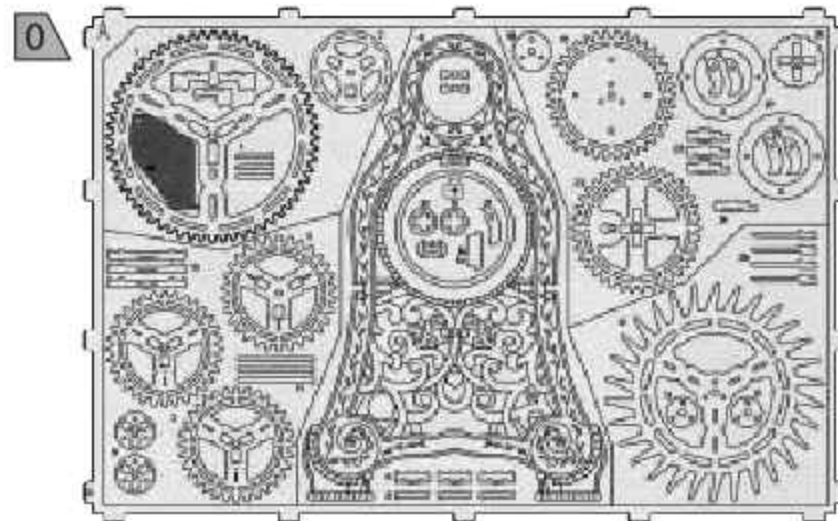

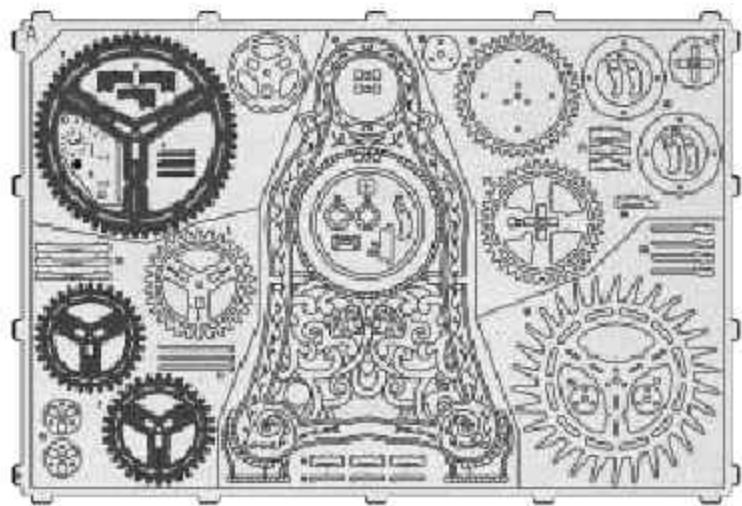

1

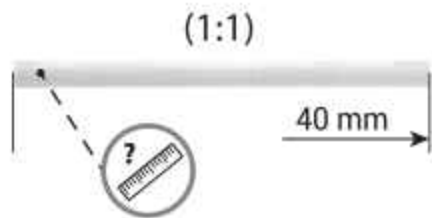

(1:1)

40 mm

1

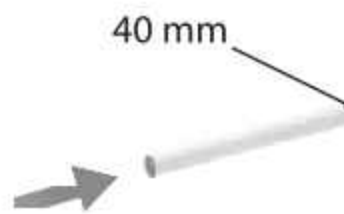

40 mm

2

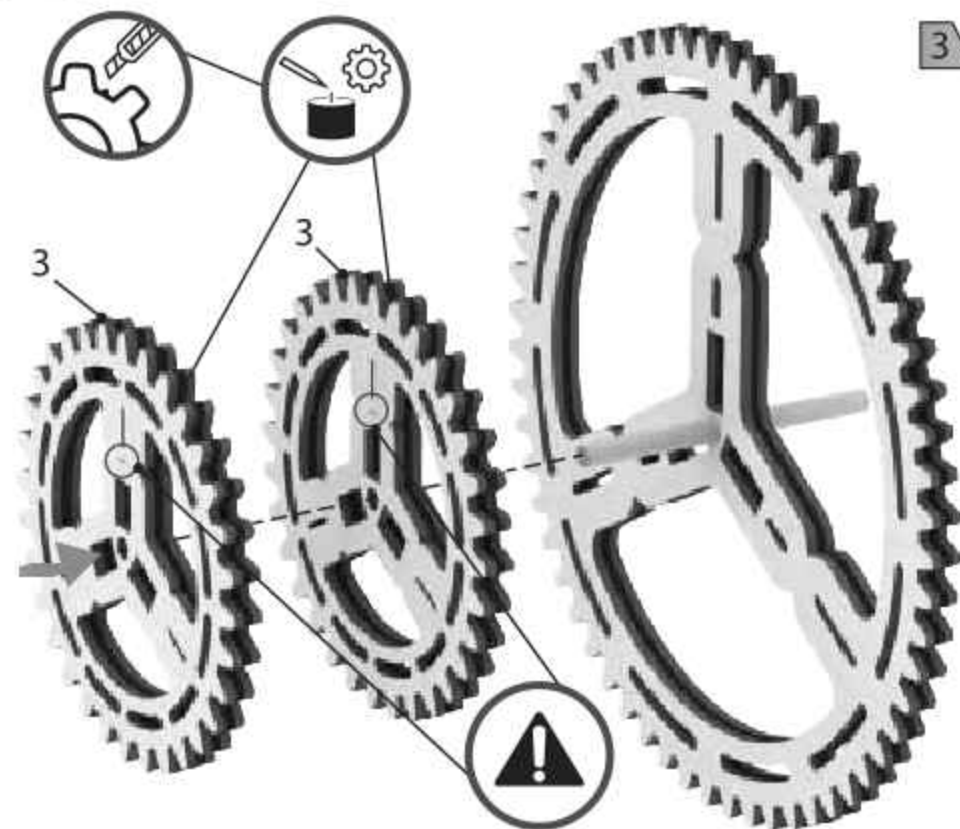

3



4

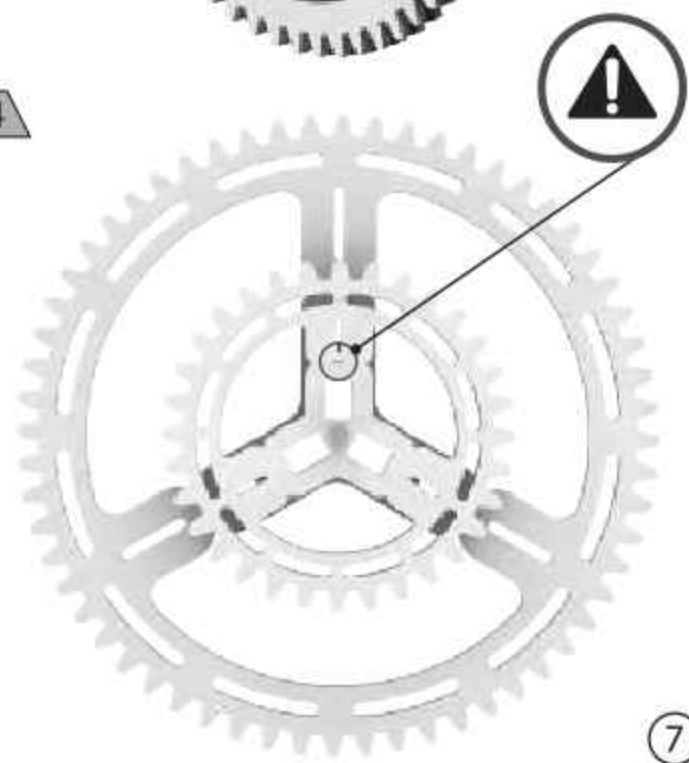

7

5

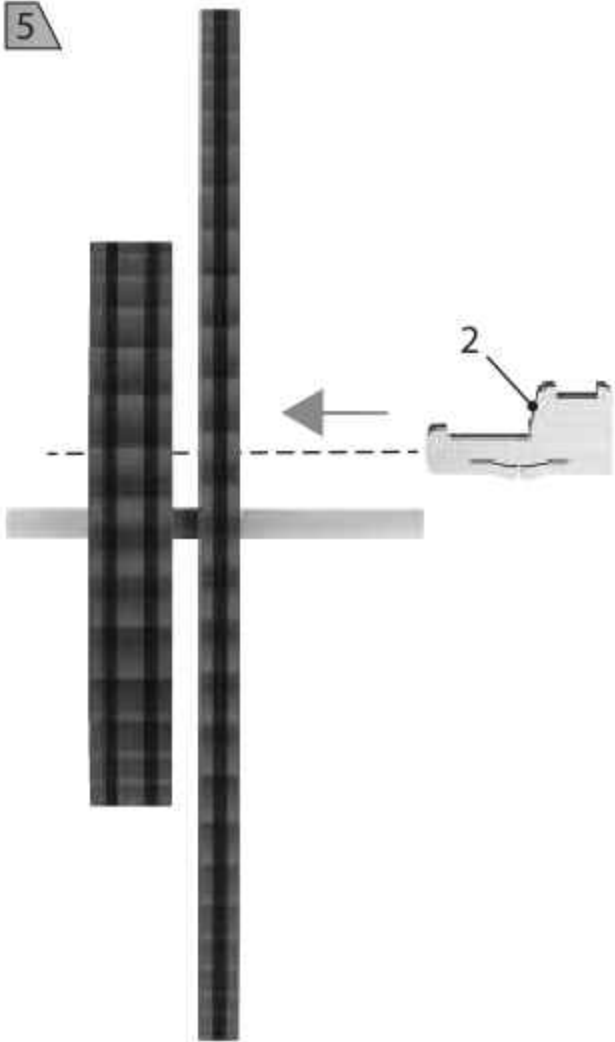

6

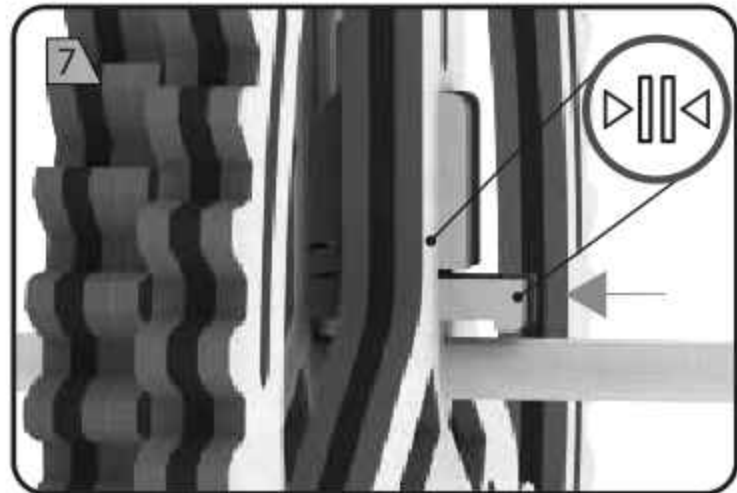
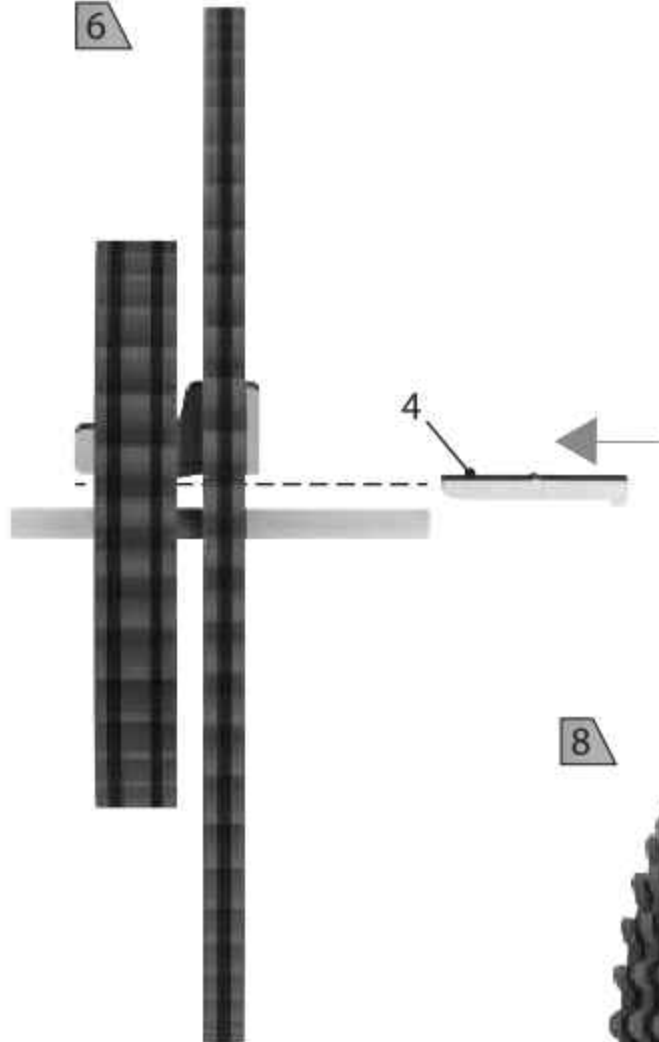

8

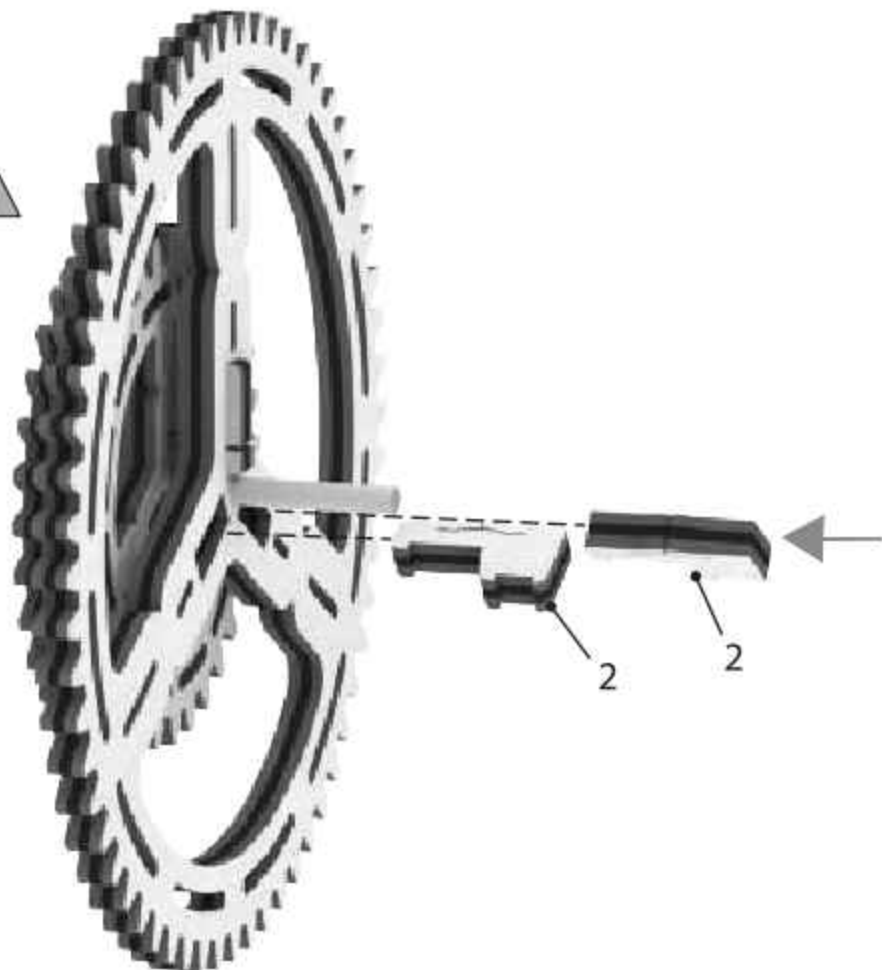

8



9

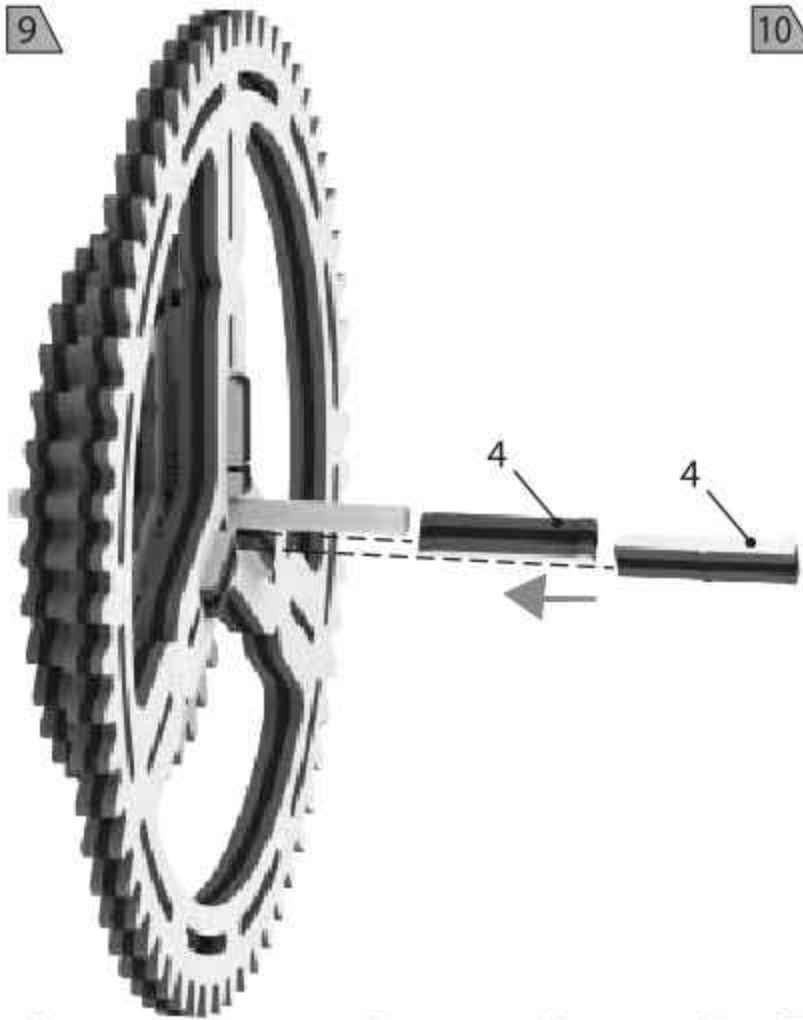

10



11

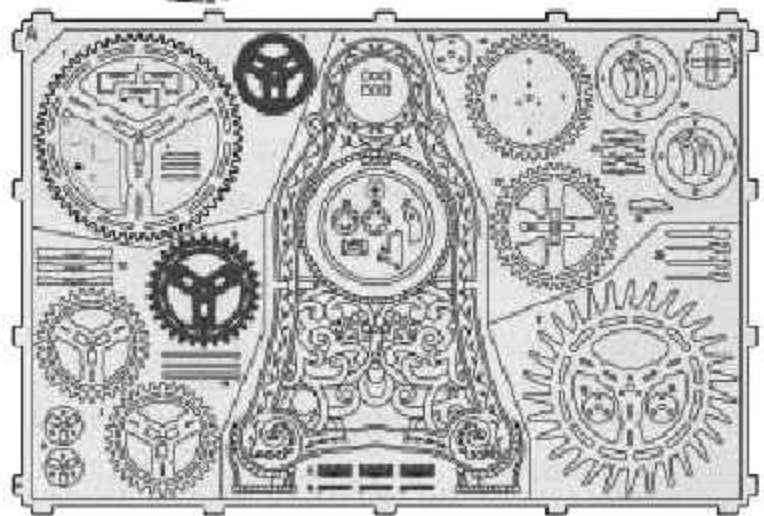
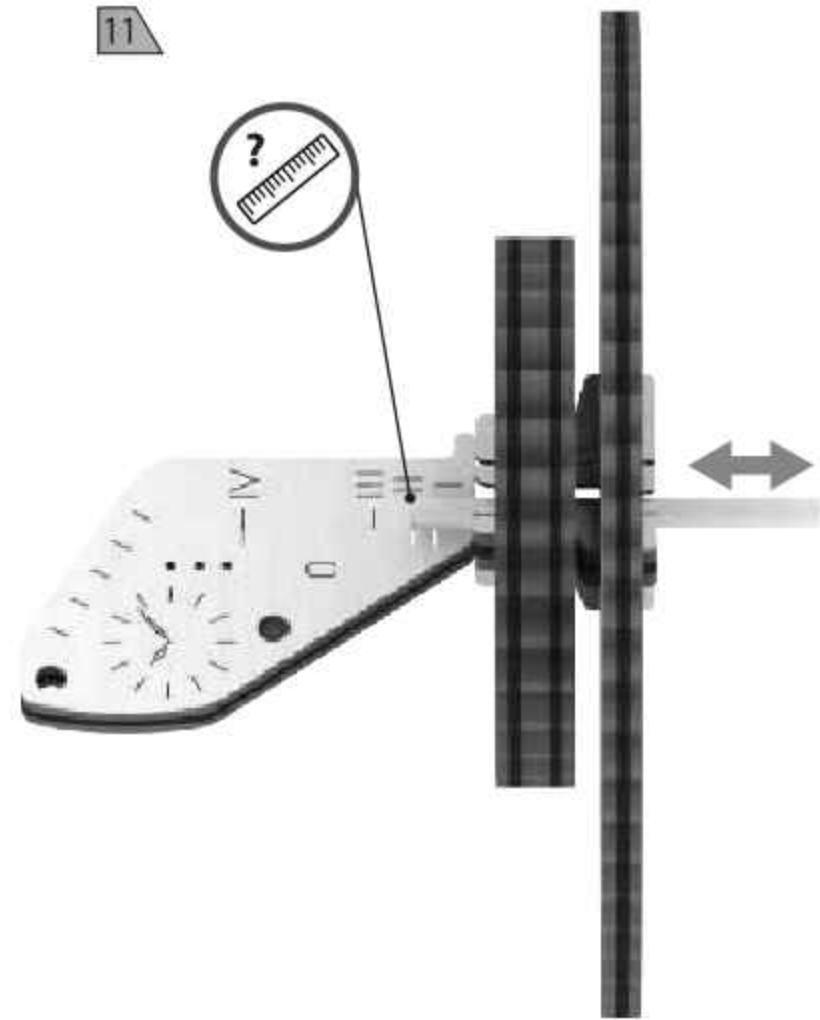

1

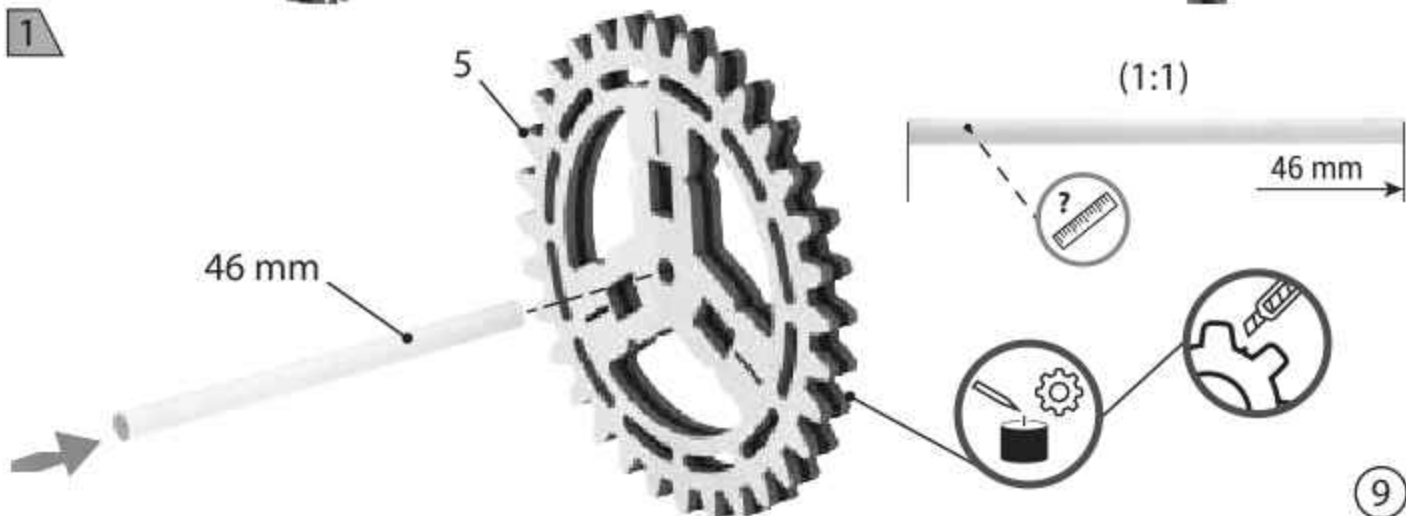

9

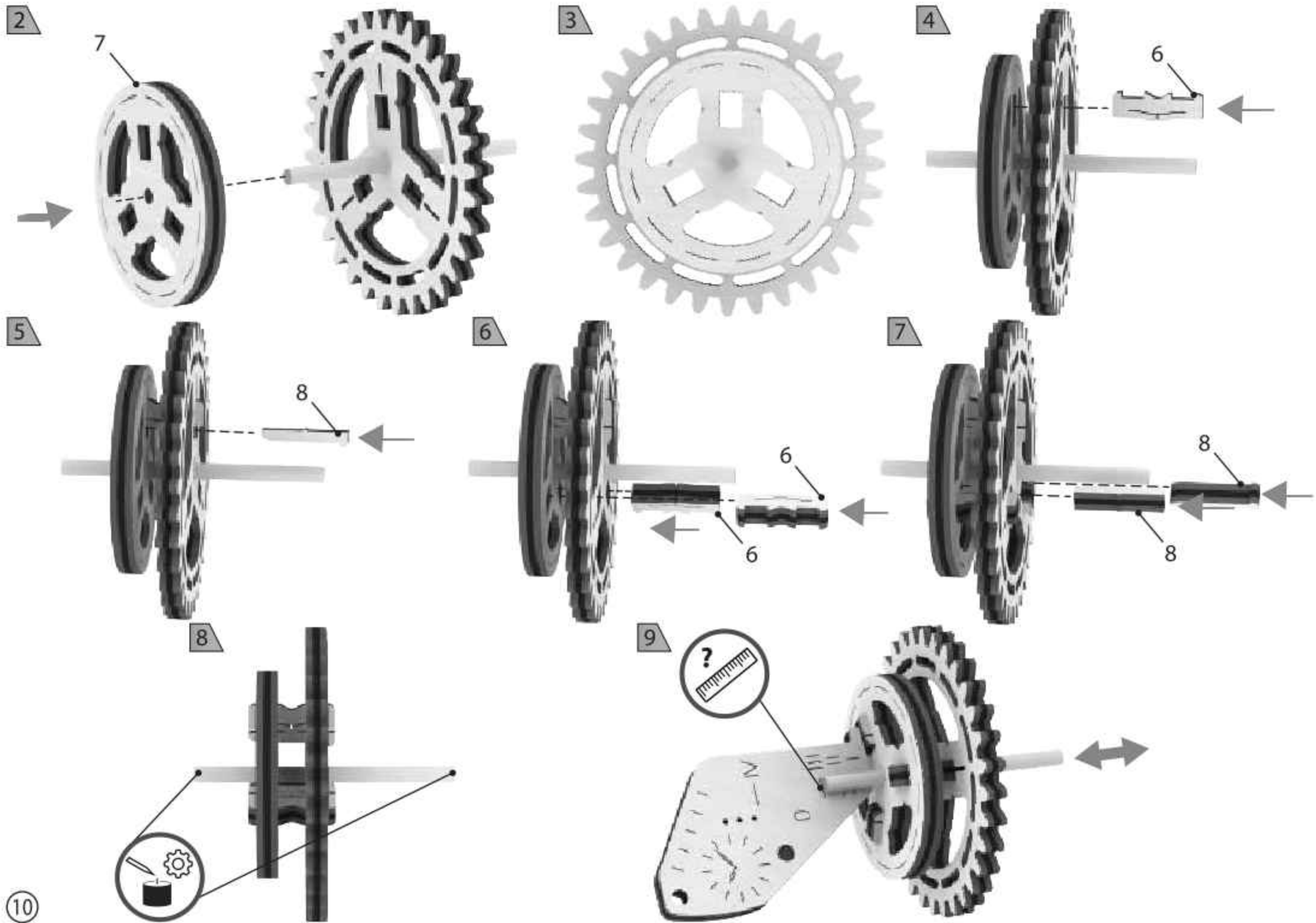



7

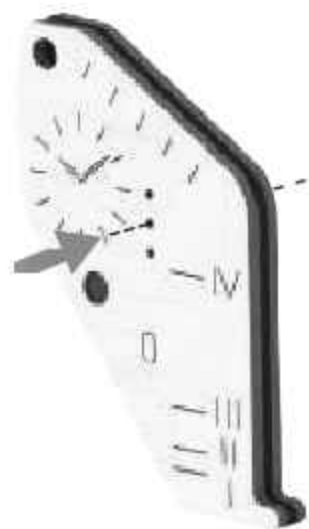

8

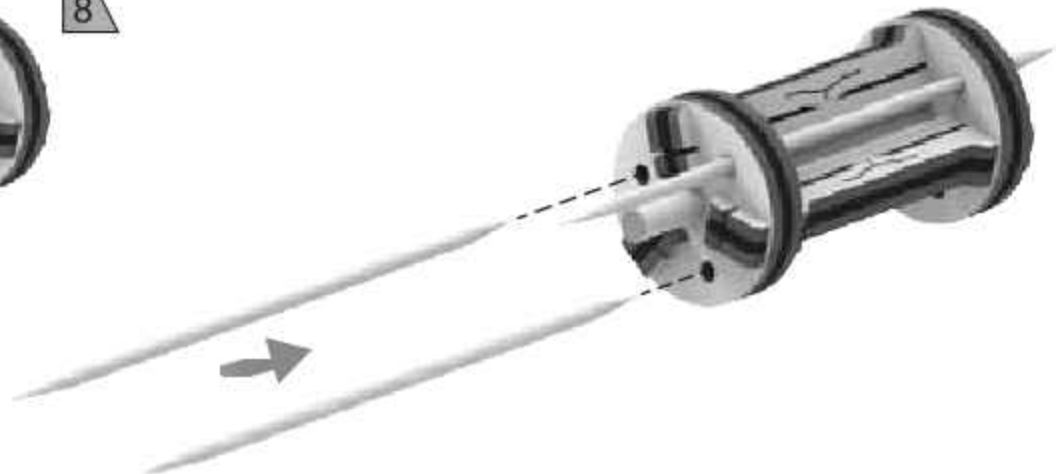

9



10



11

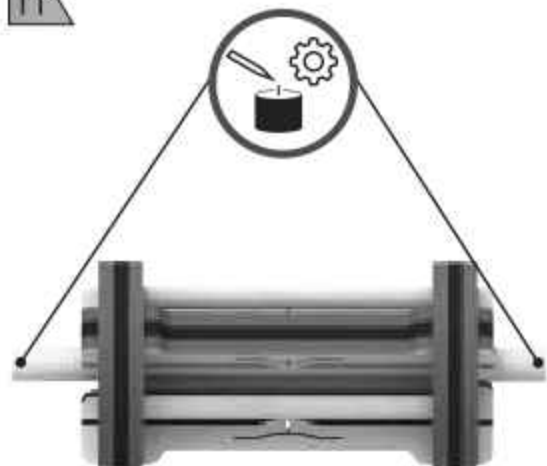

12

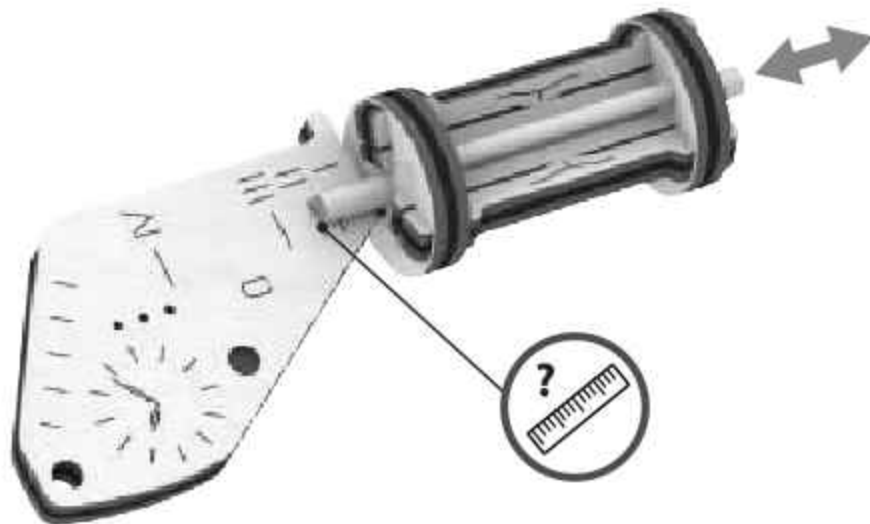

12

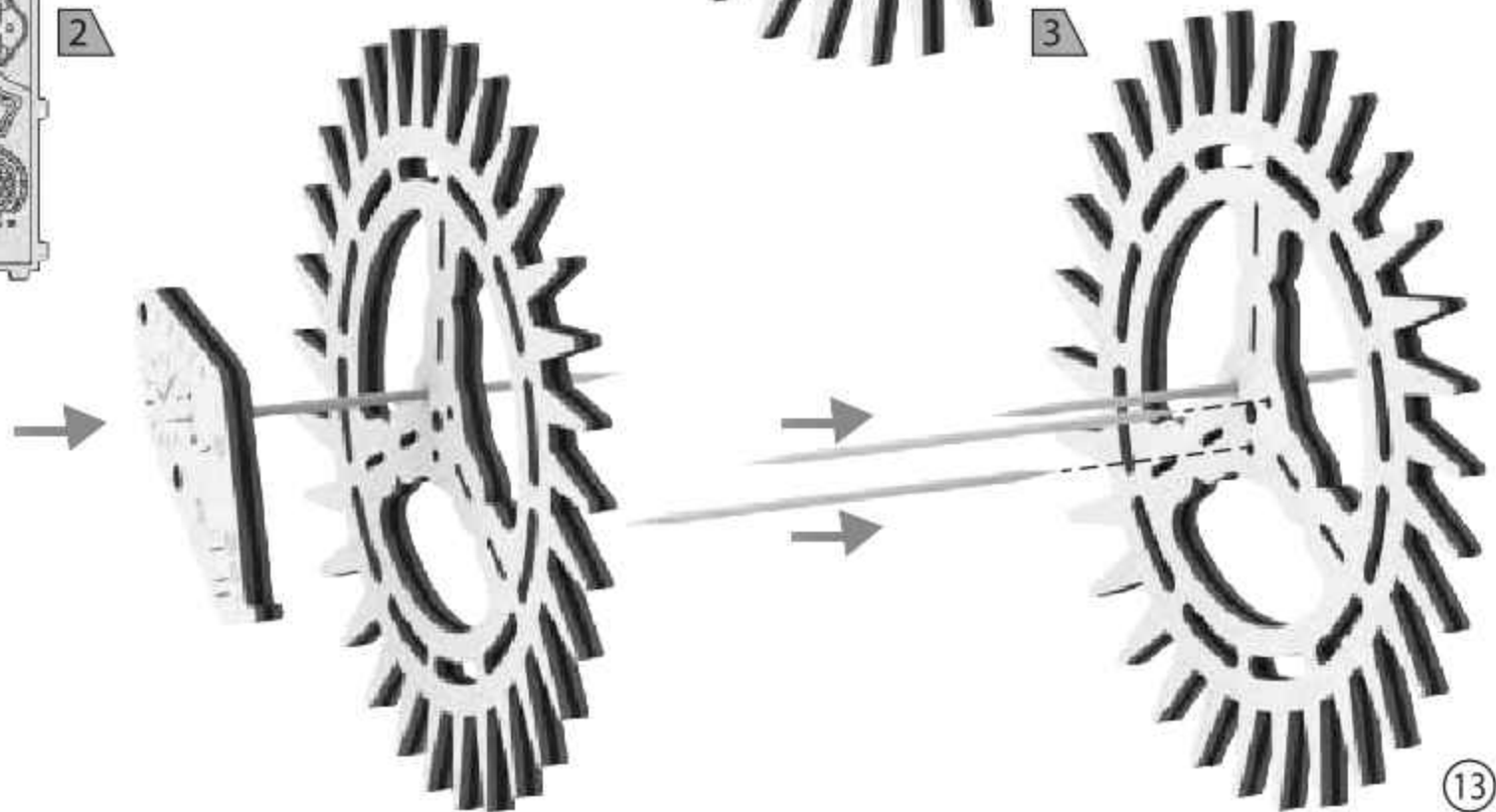
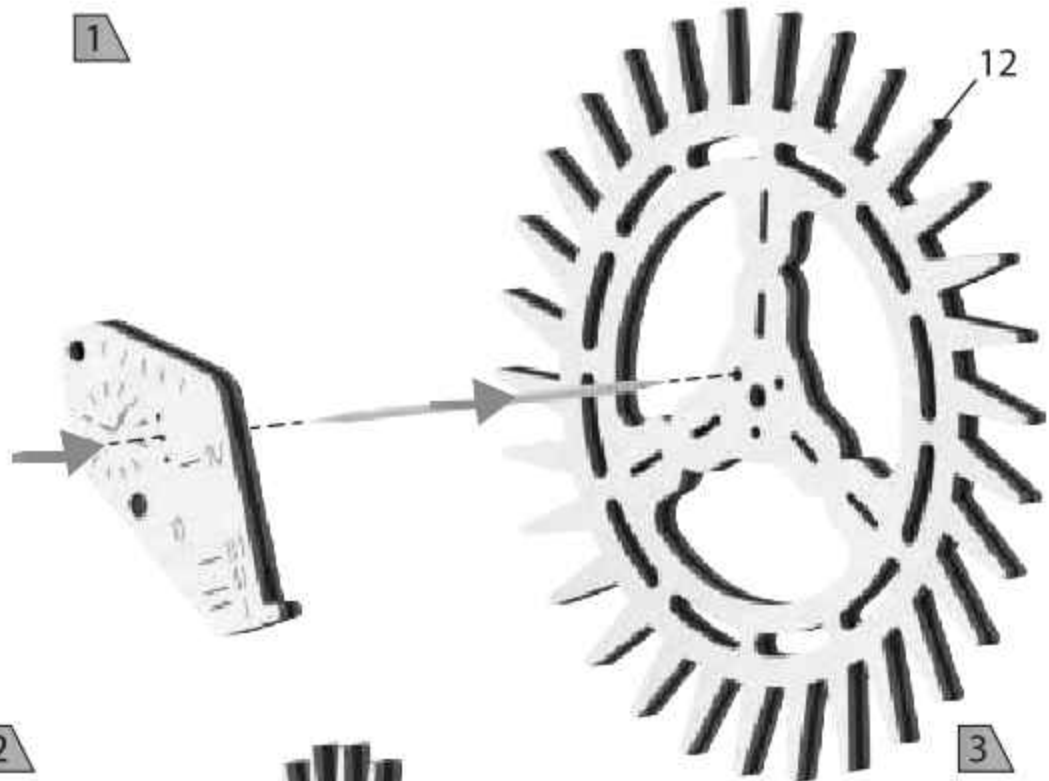
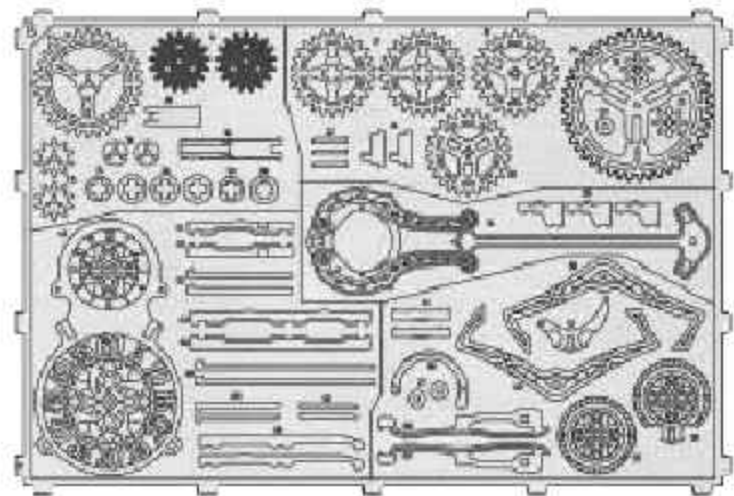
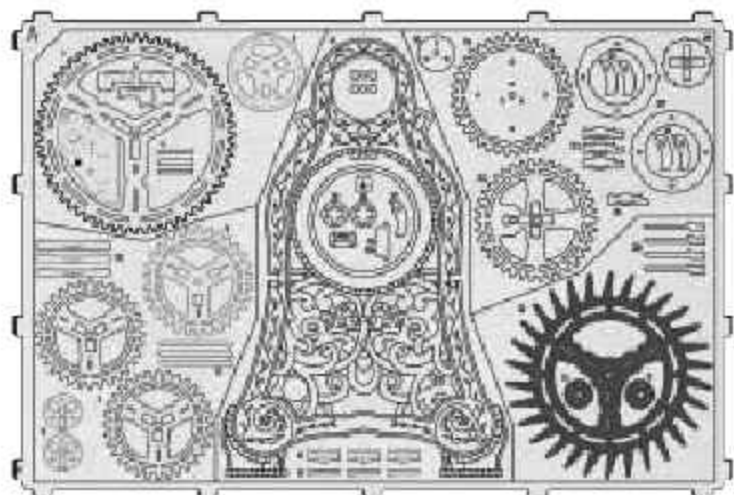



4

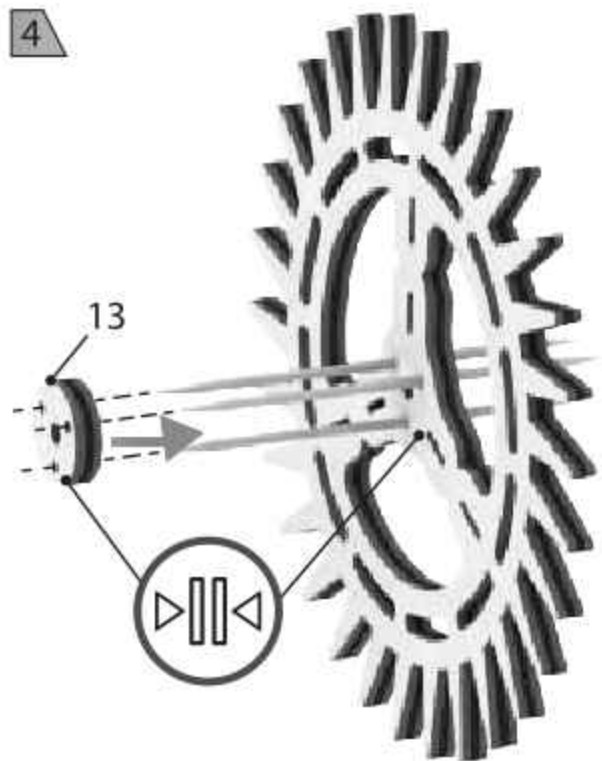

5

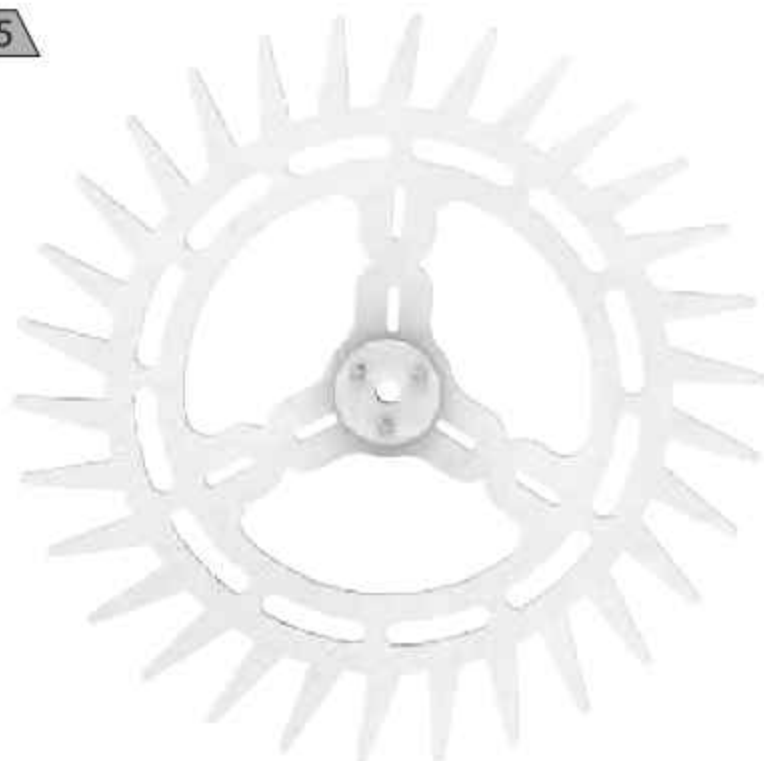

6

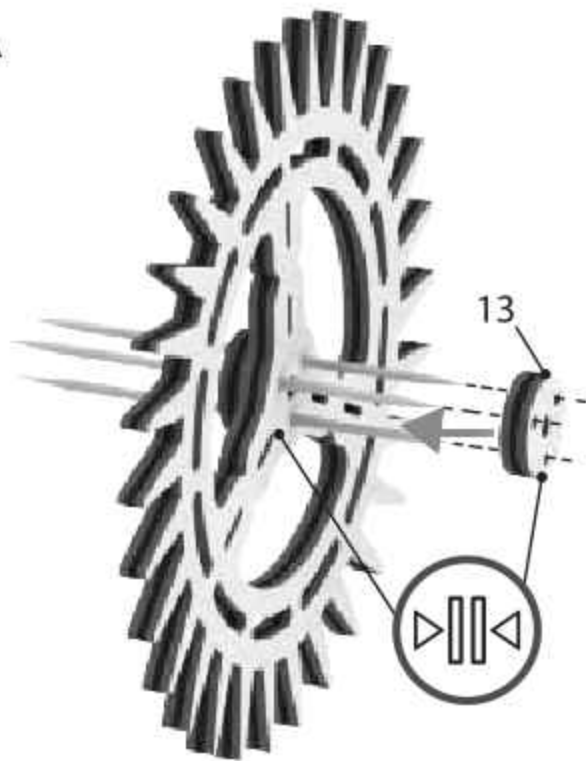

7



8

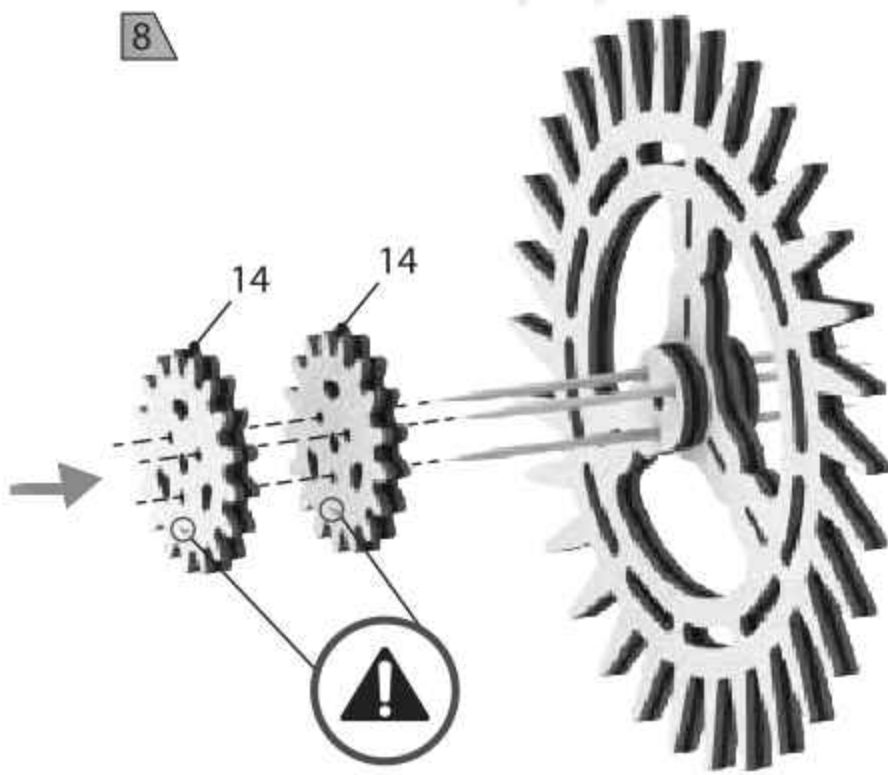

9



14



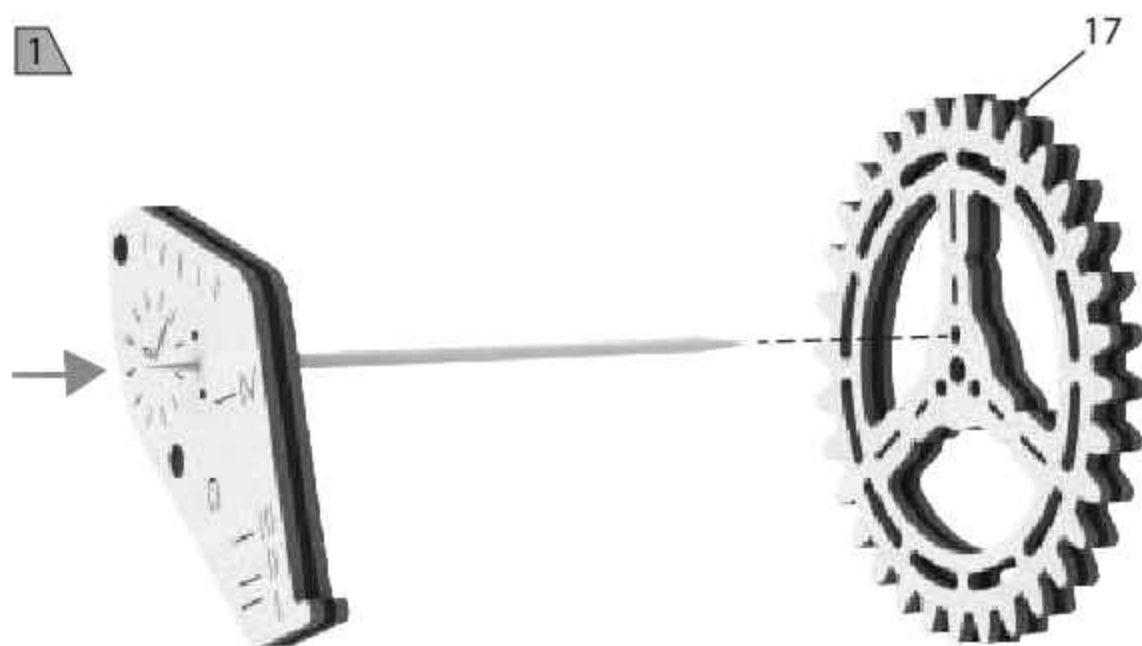
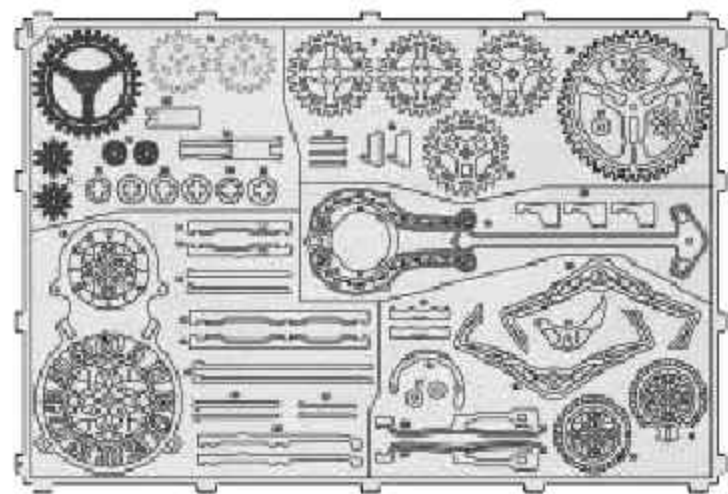
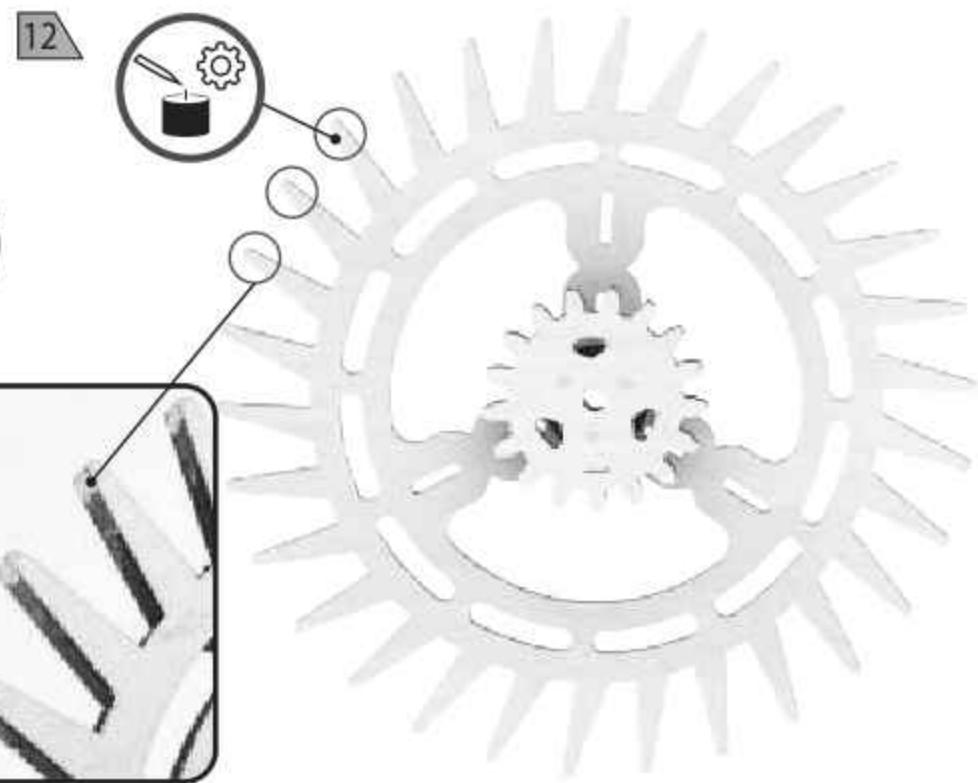
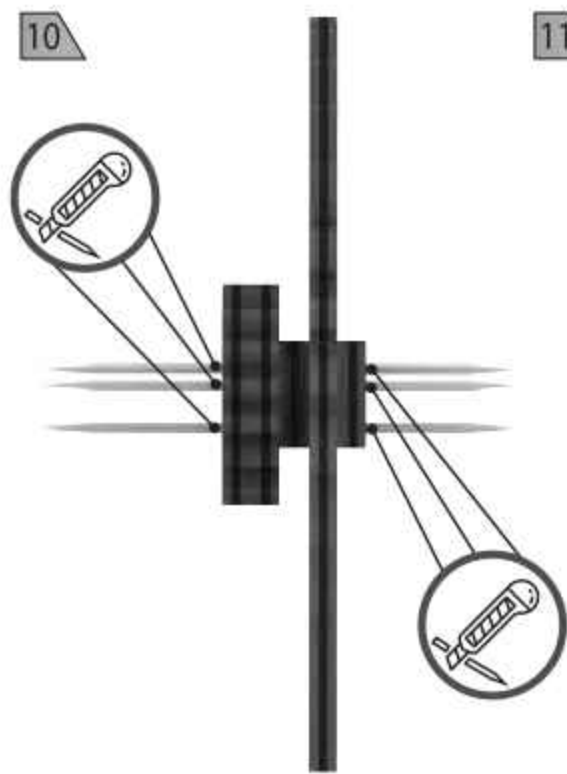



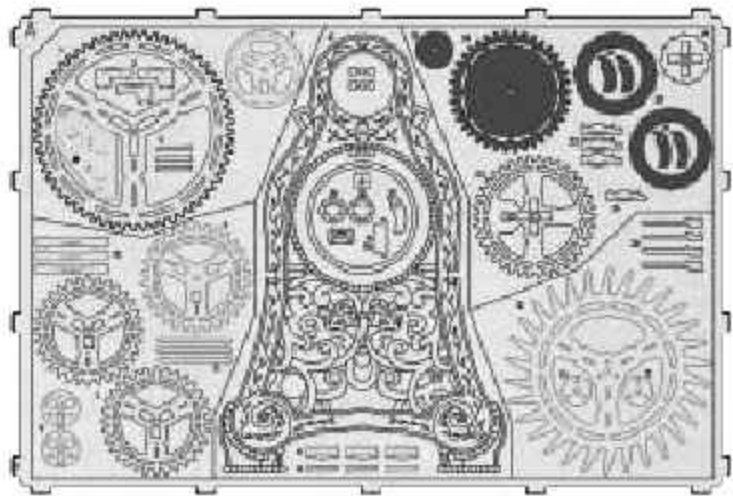

1

3x8 mm

8 mm

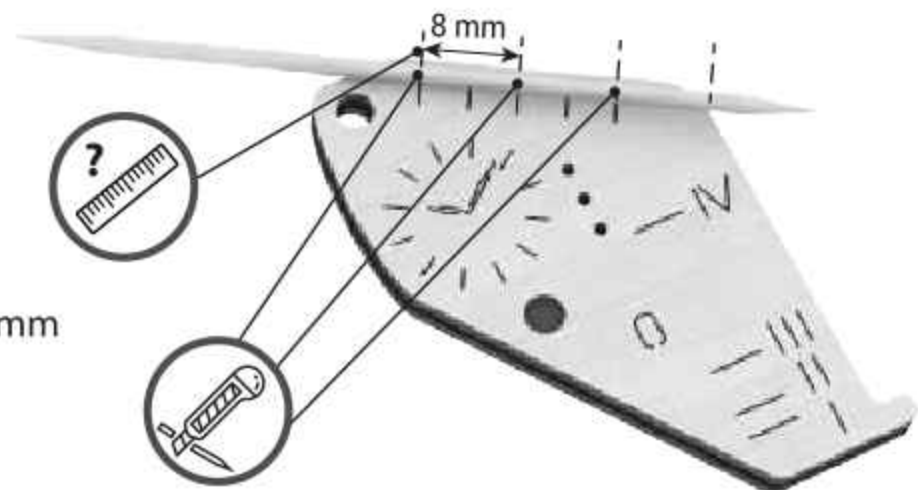

2

3

4

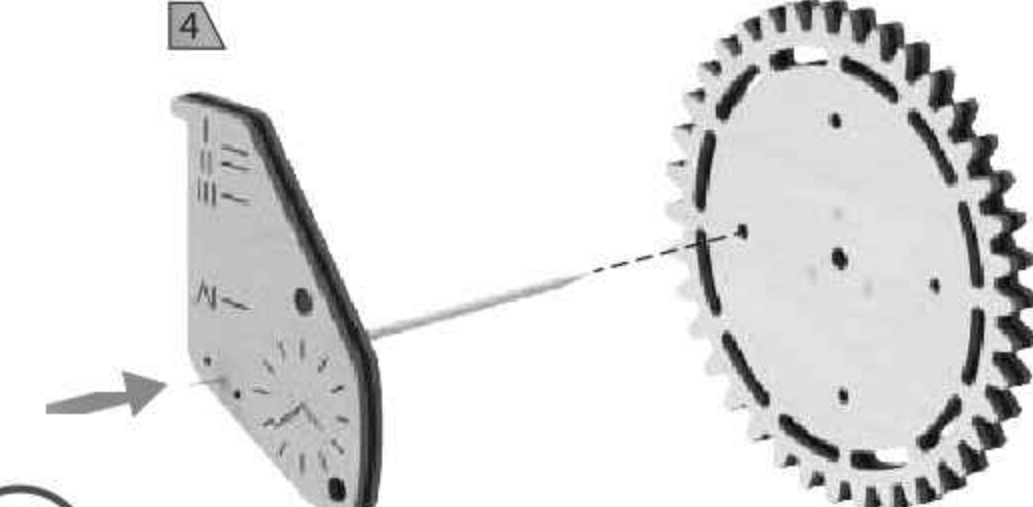
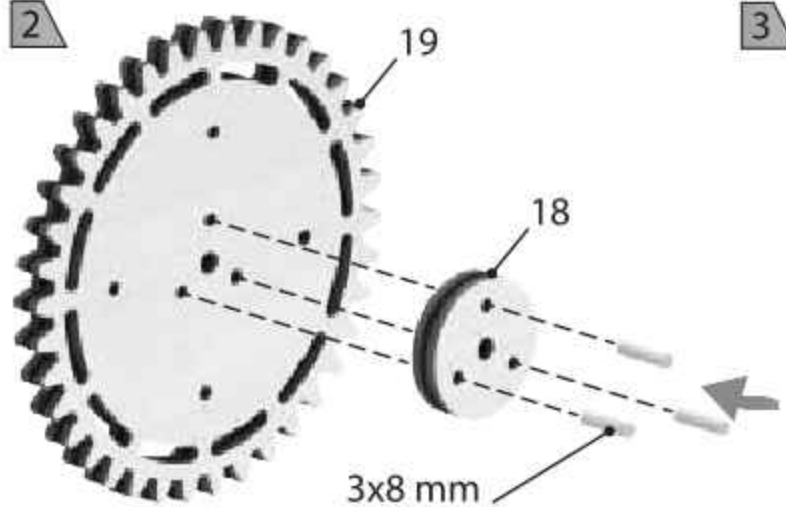

5

6

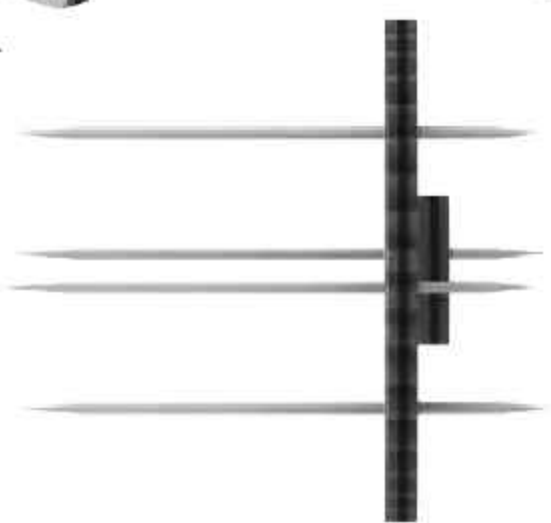
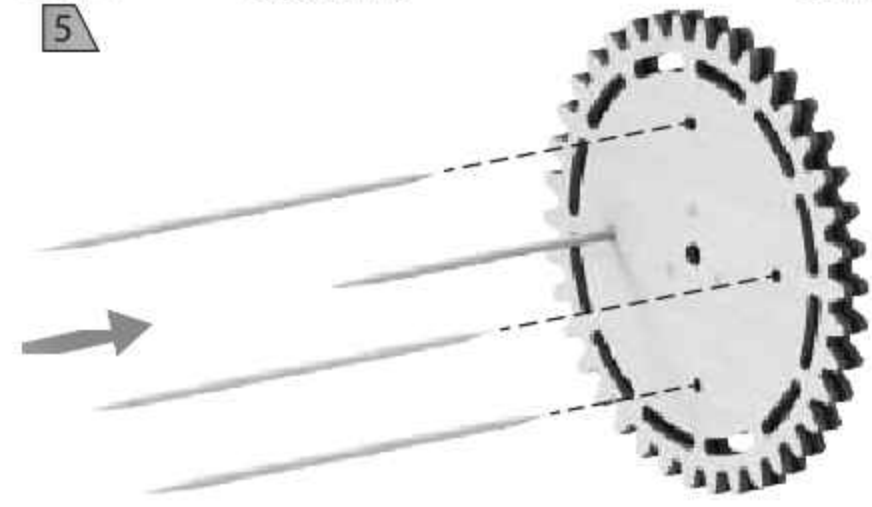

7

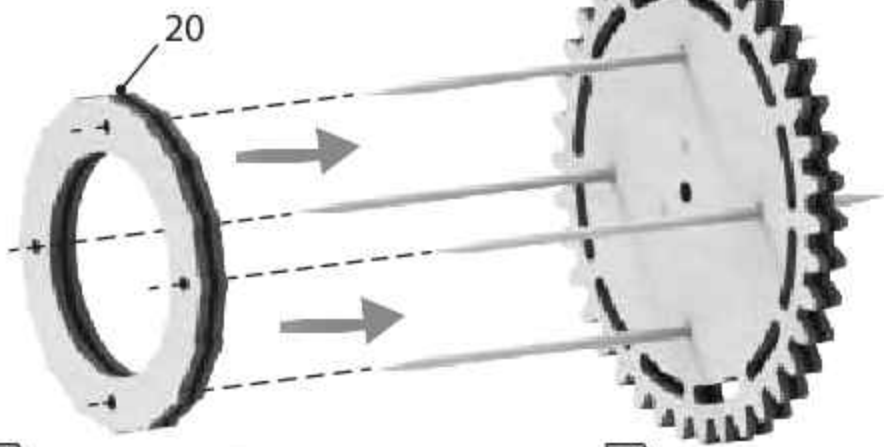

8

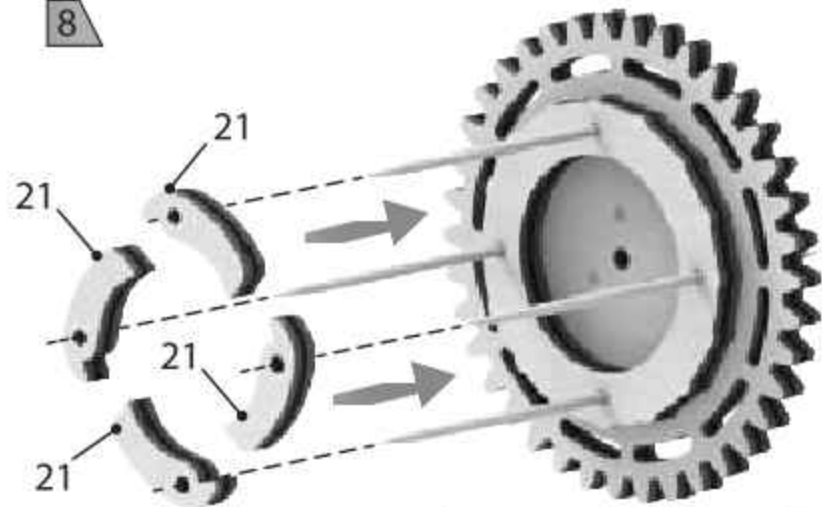

9

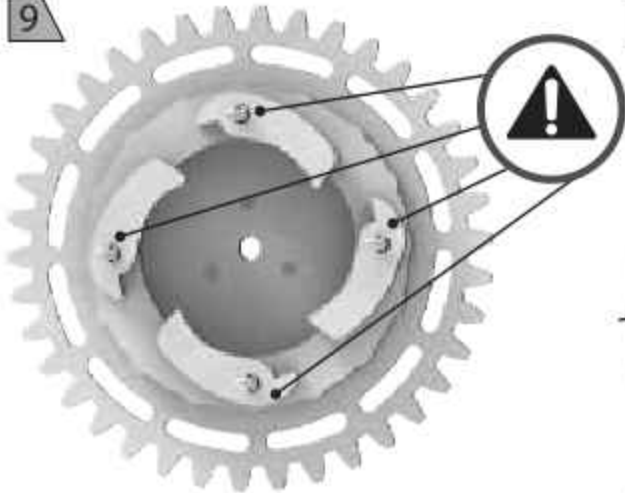

10

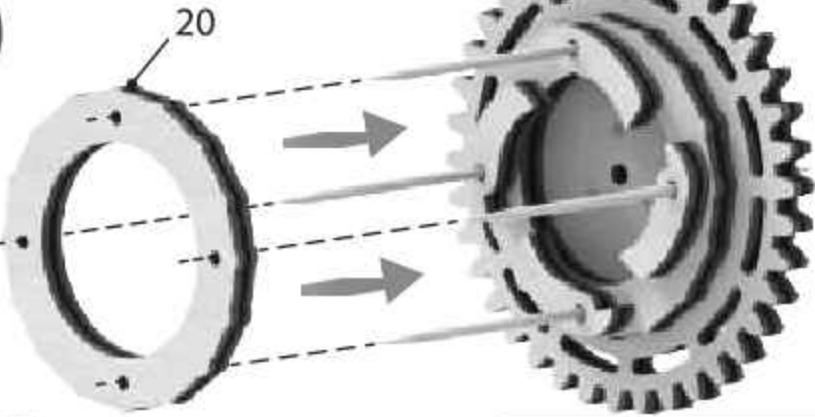

11

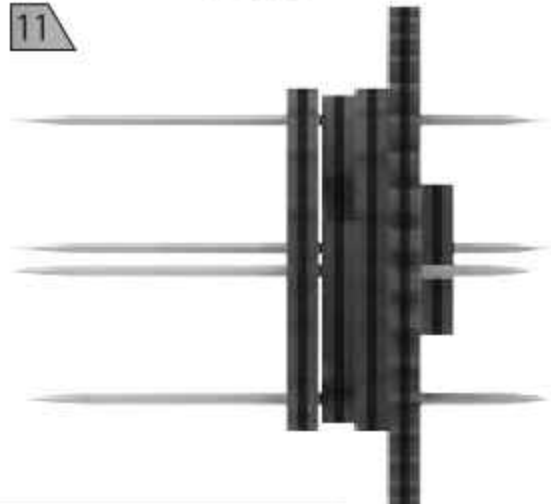

12

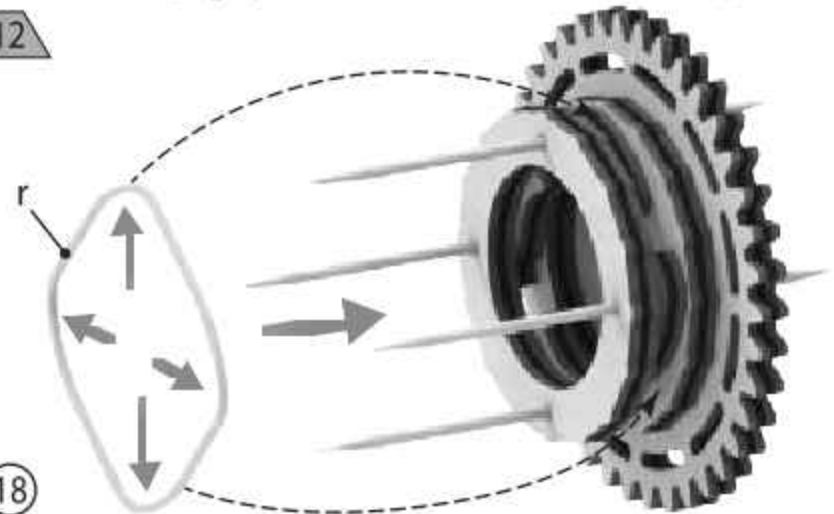

13

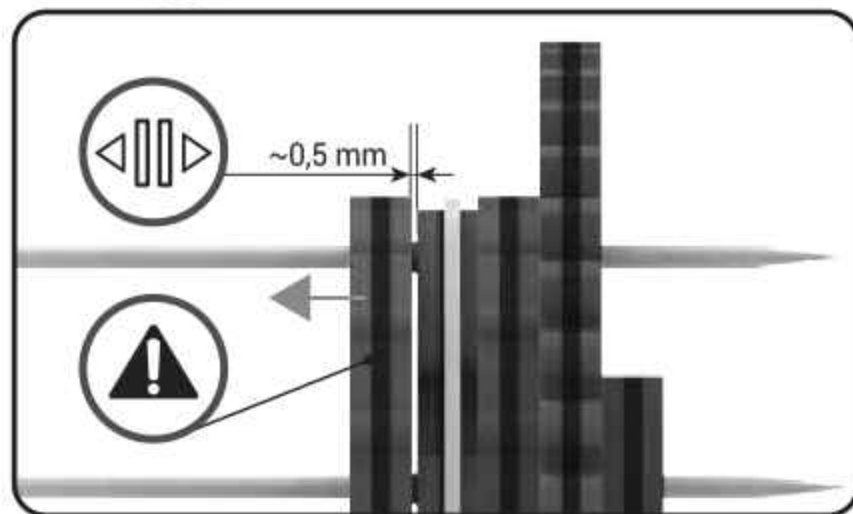



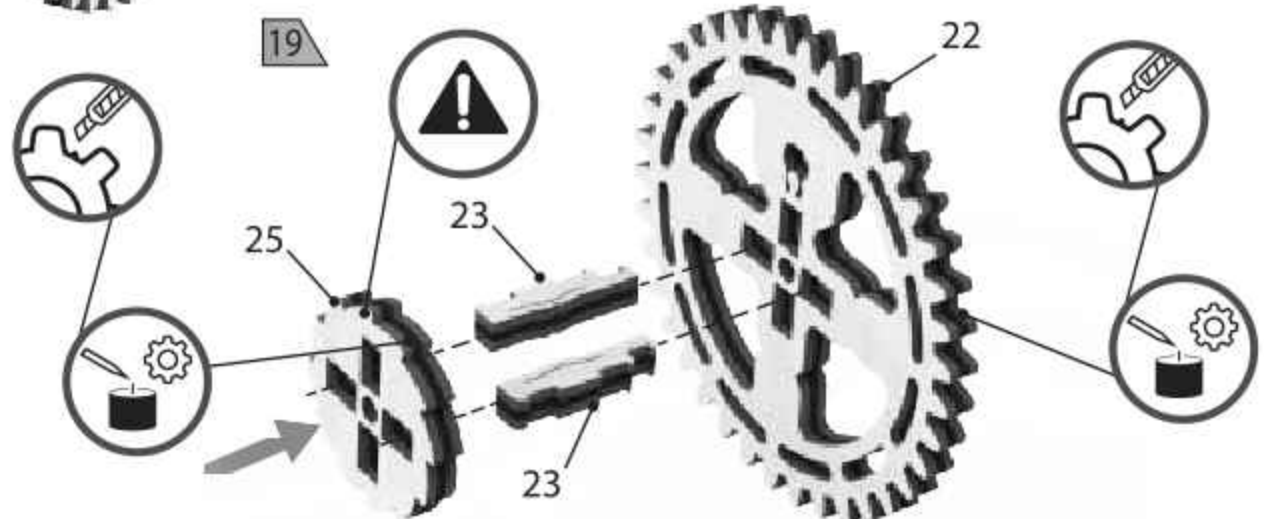
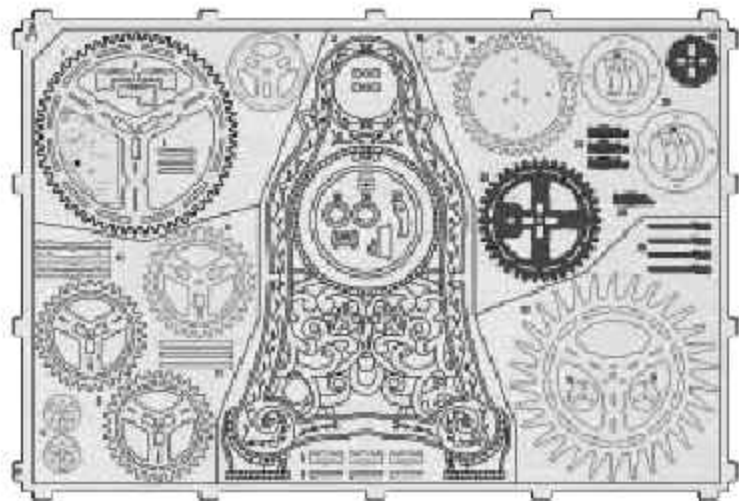
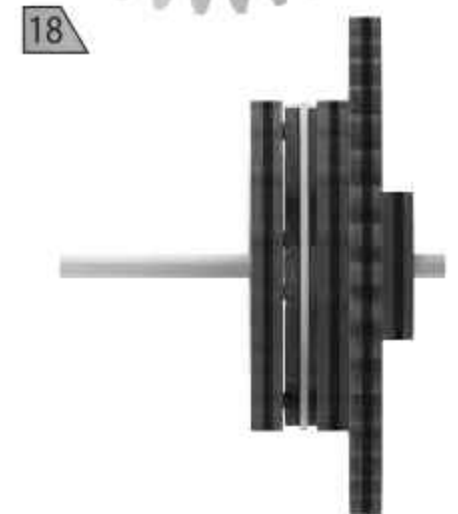
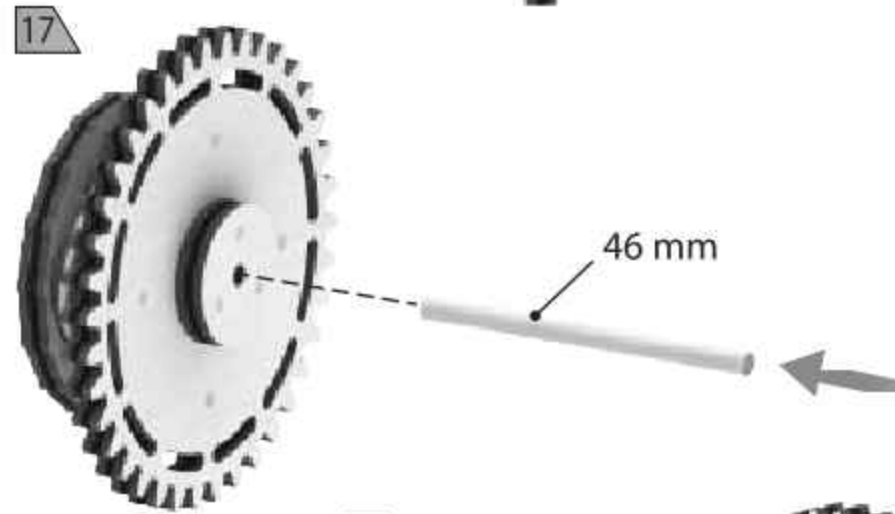
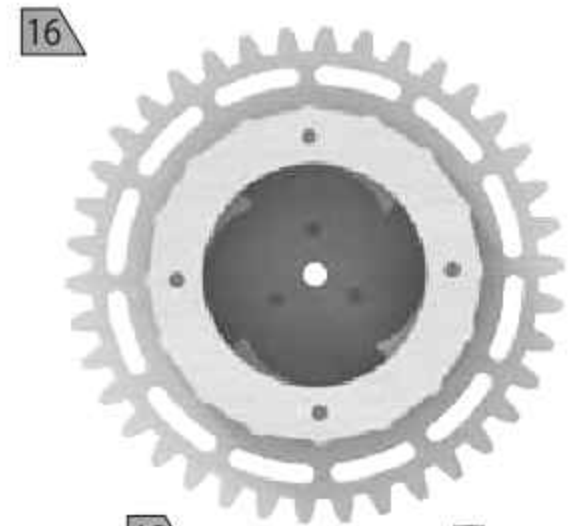
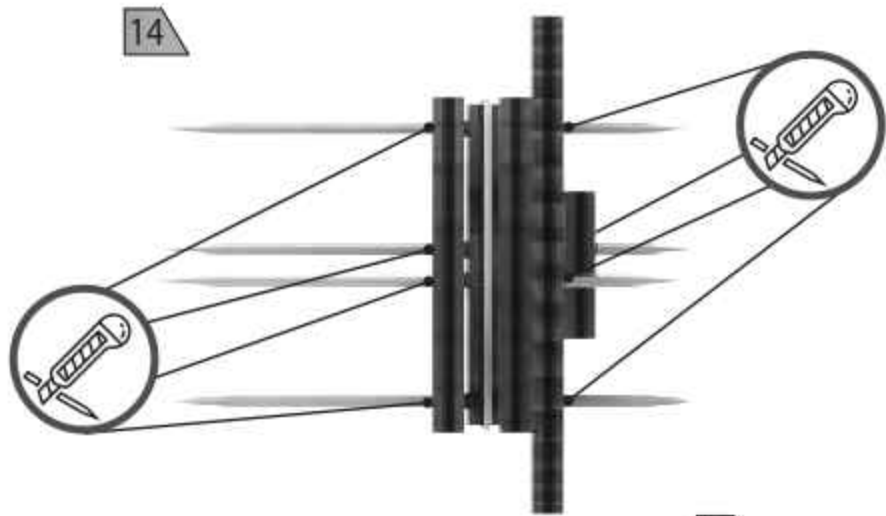

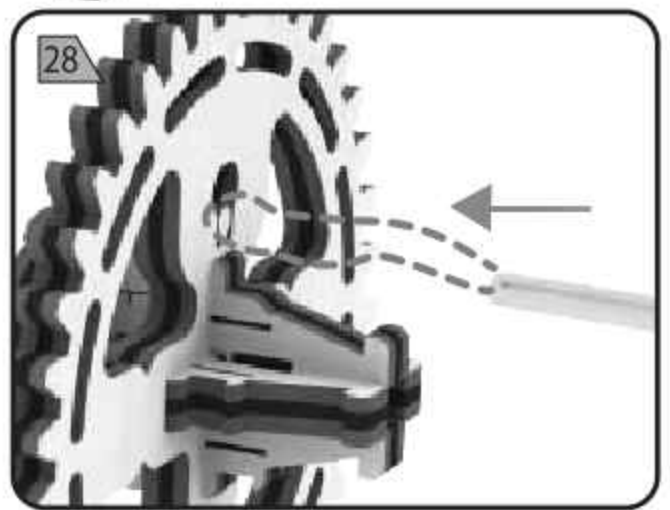
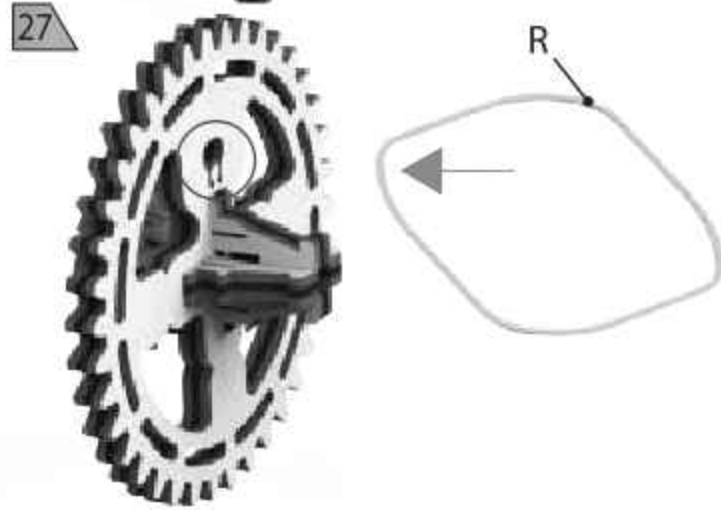
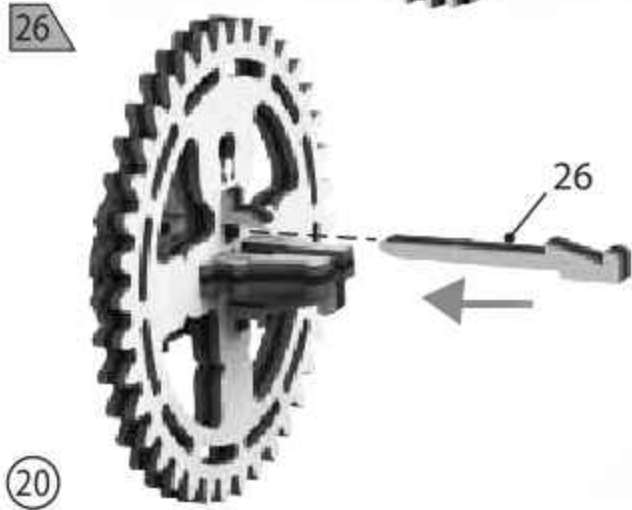
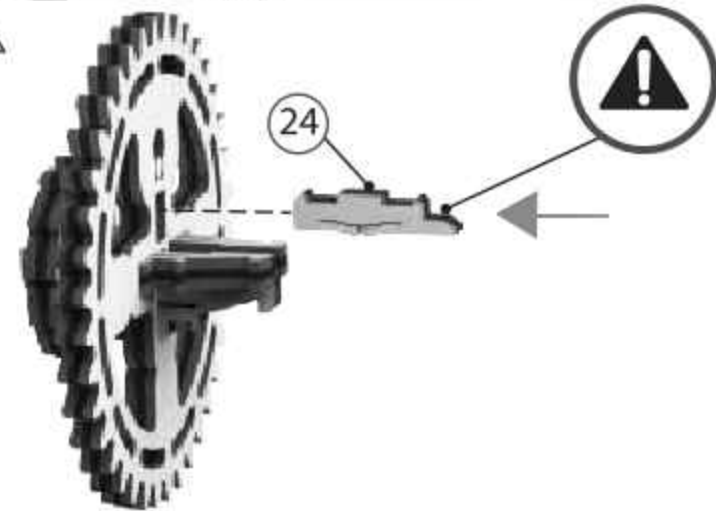
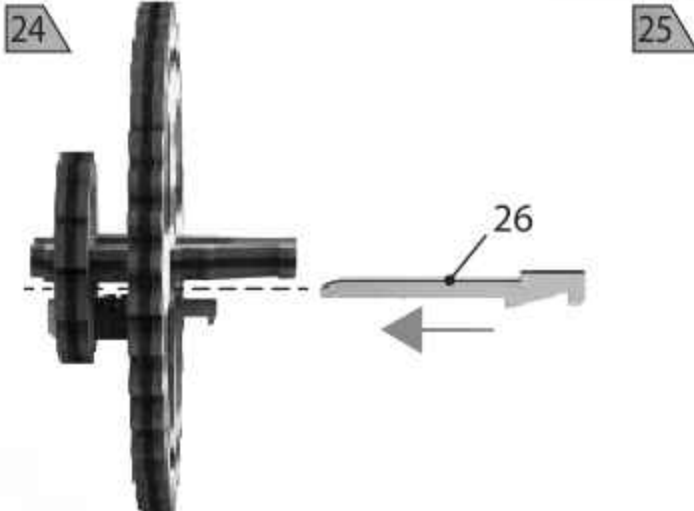
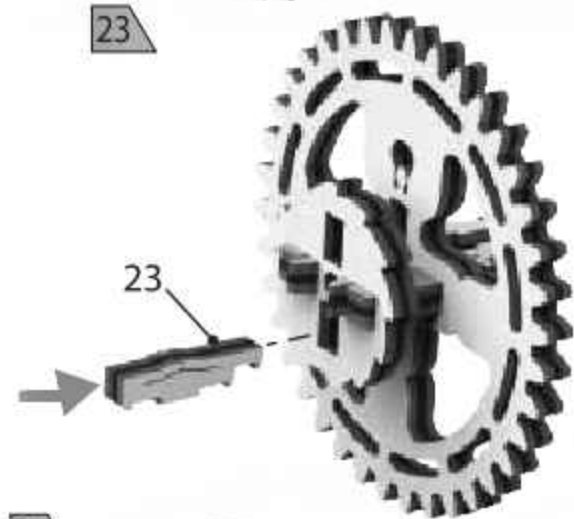
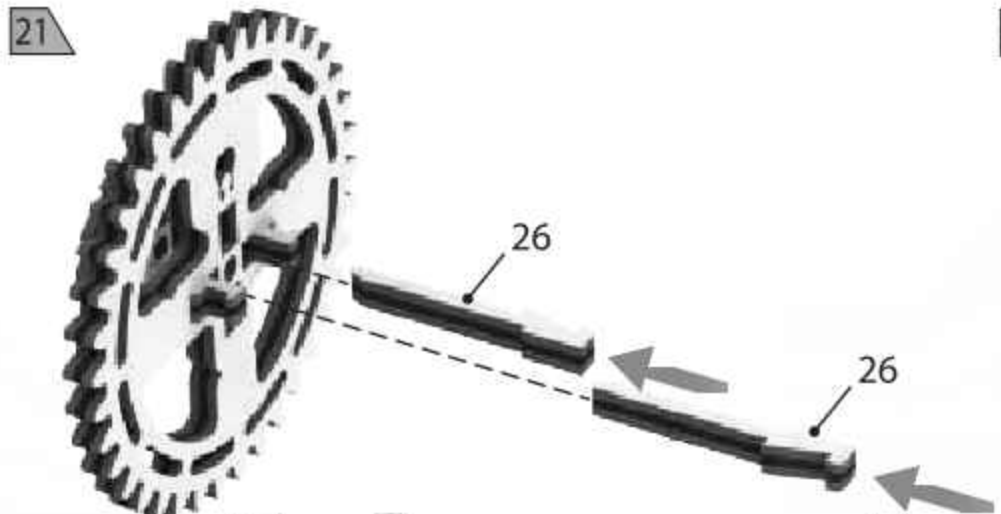

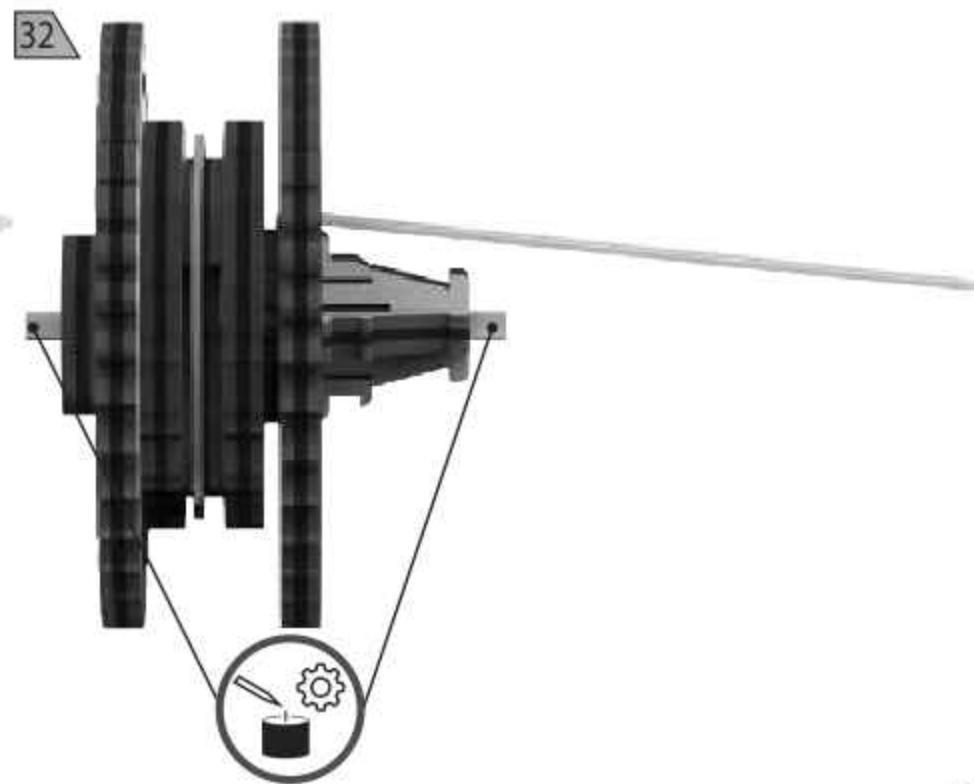
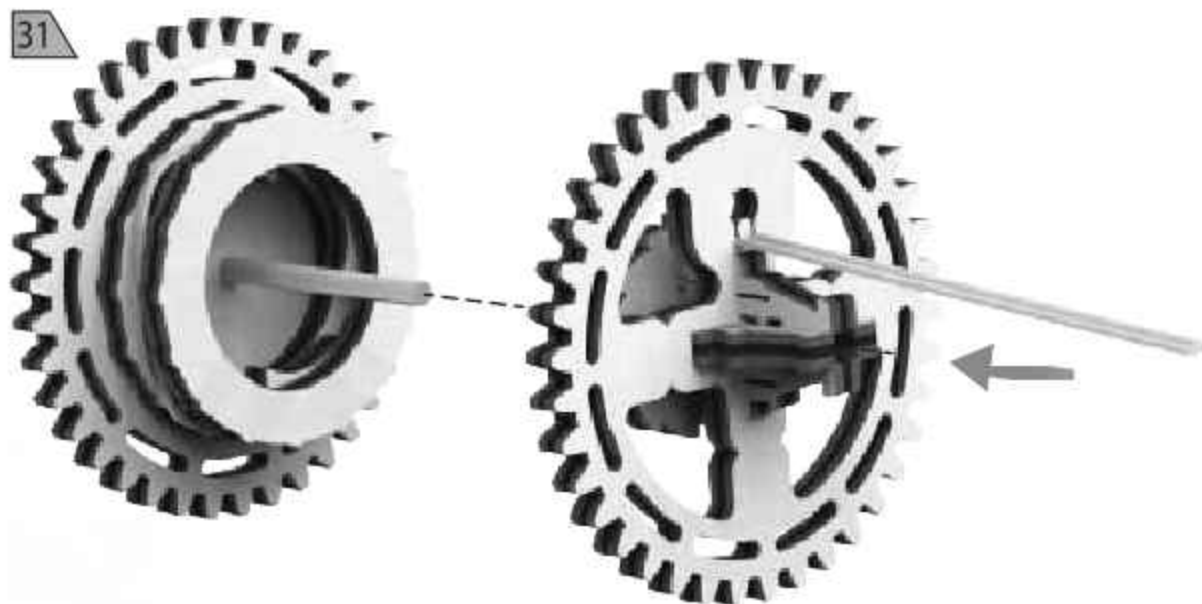
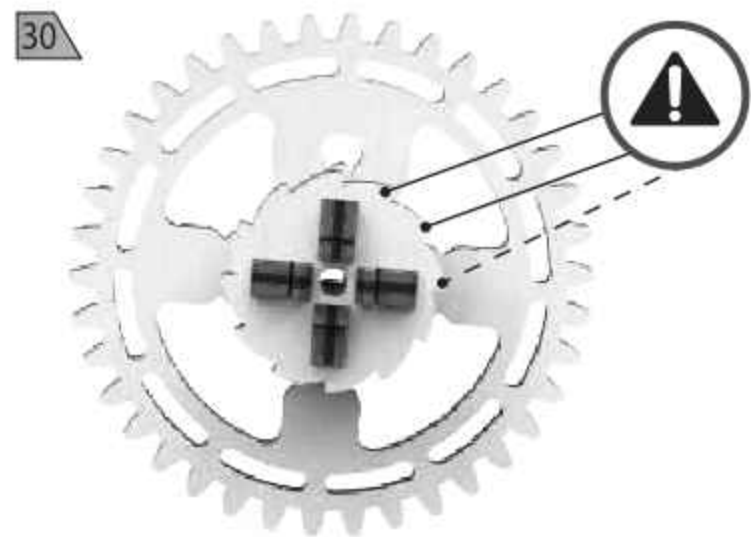
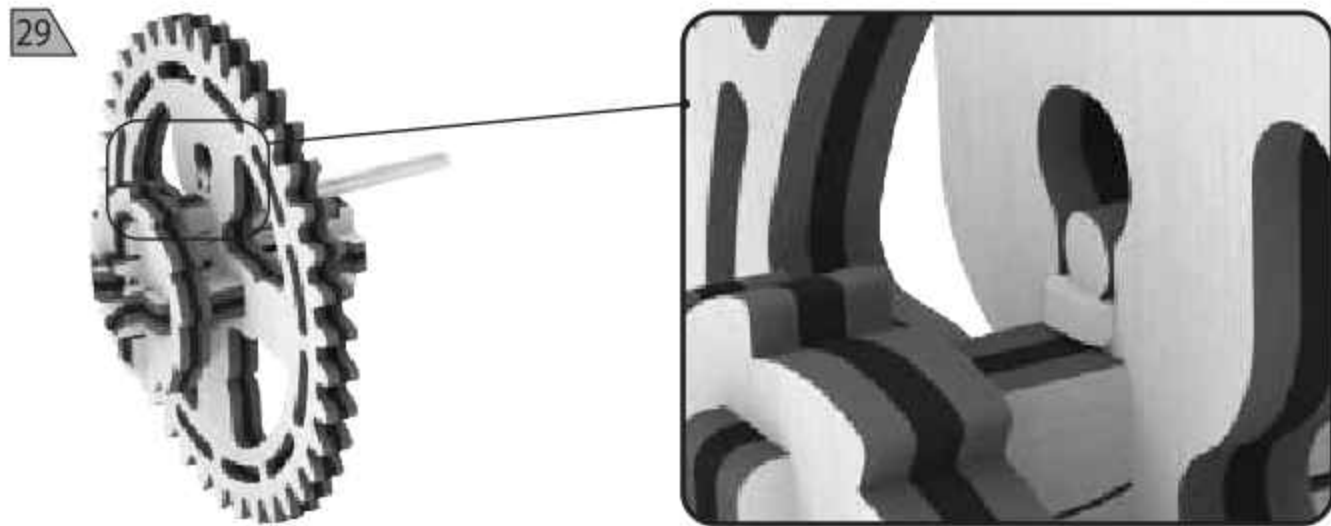

33



34



35

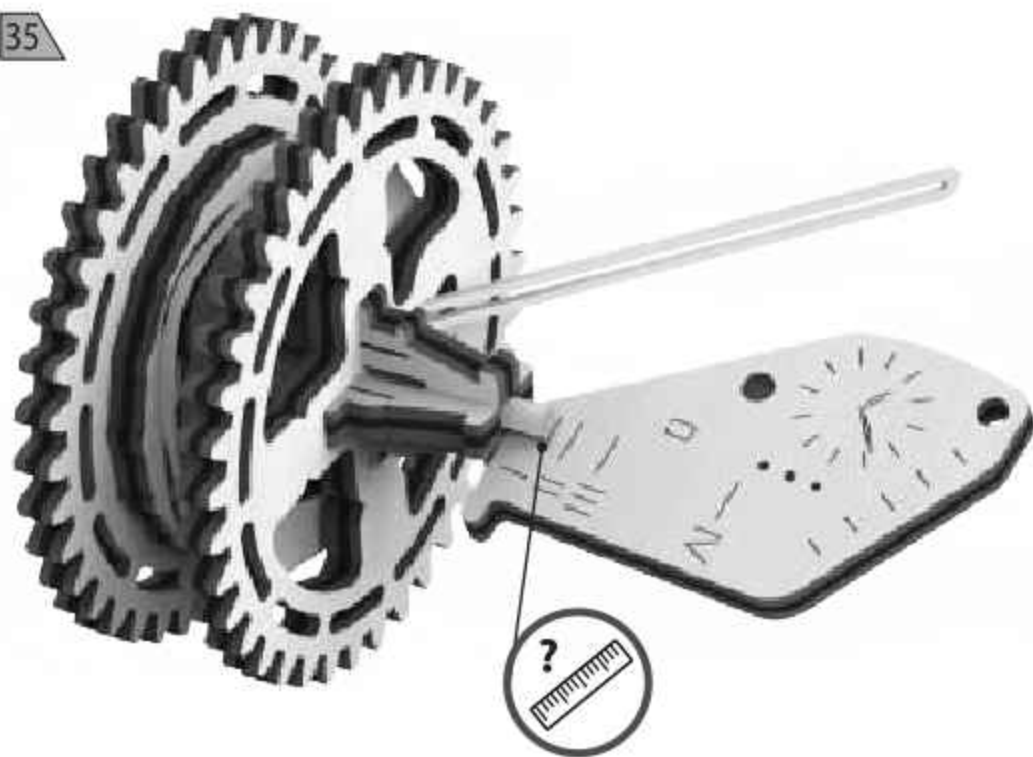



(1:1)



84 mm



30

29

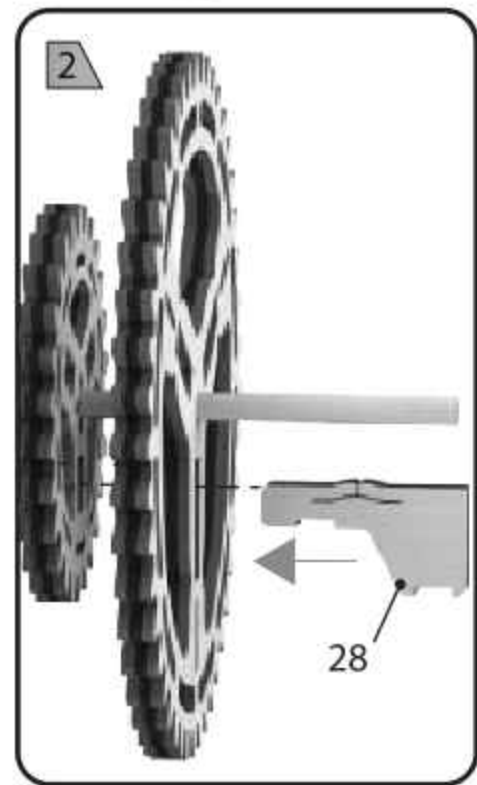
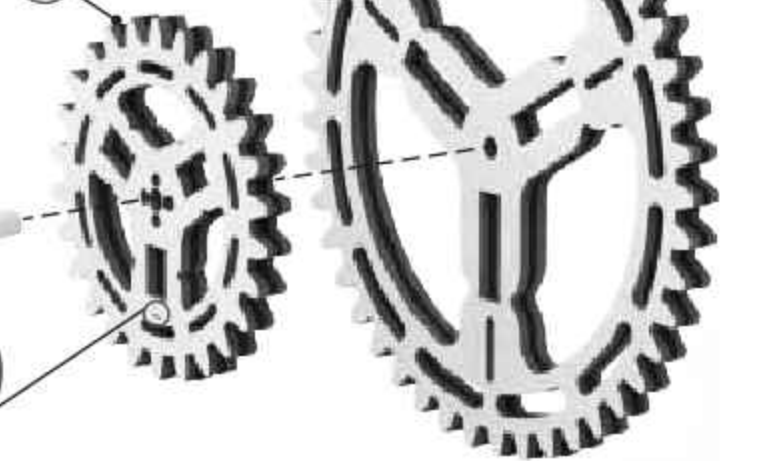

28

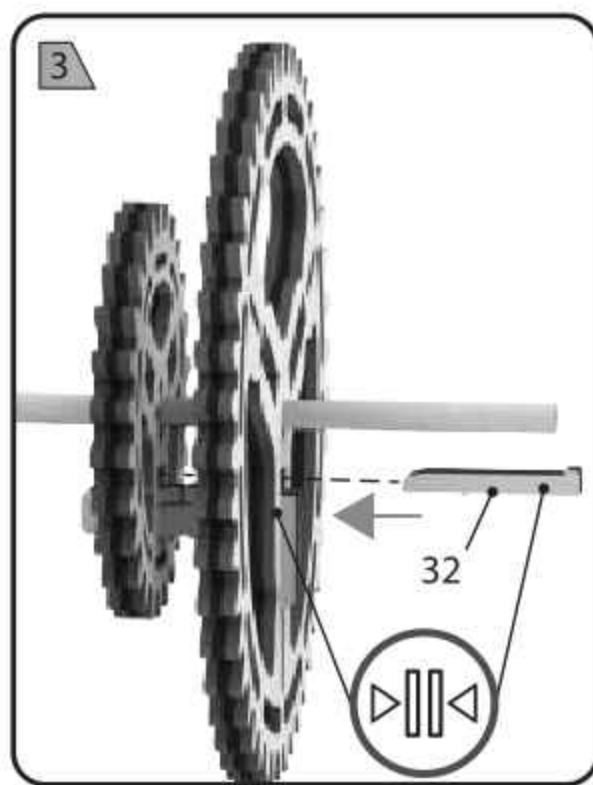

32

4

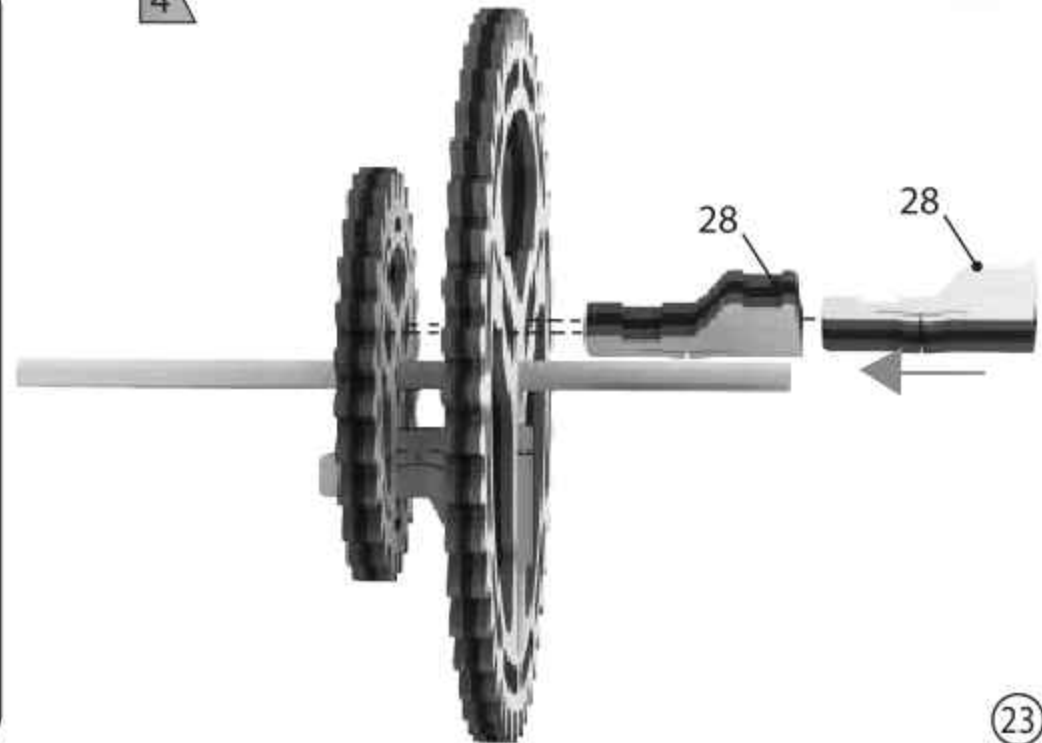

28

28



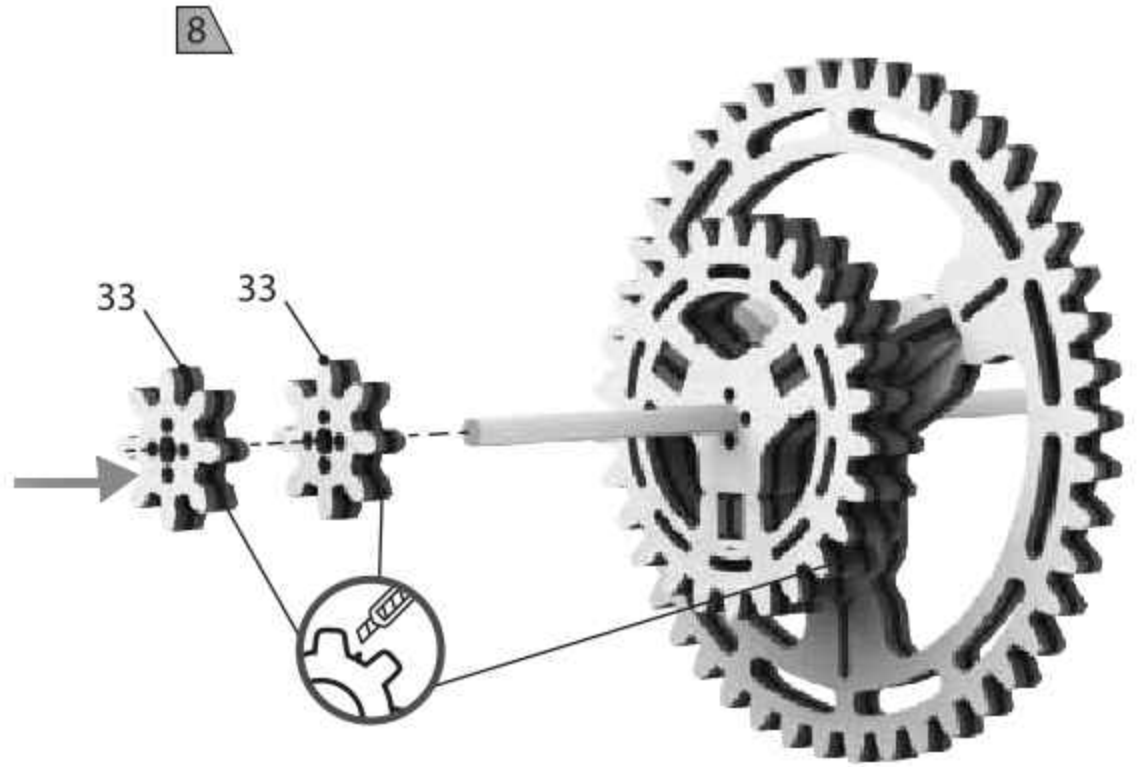
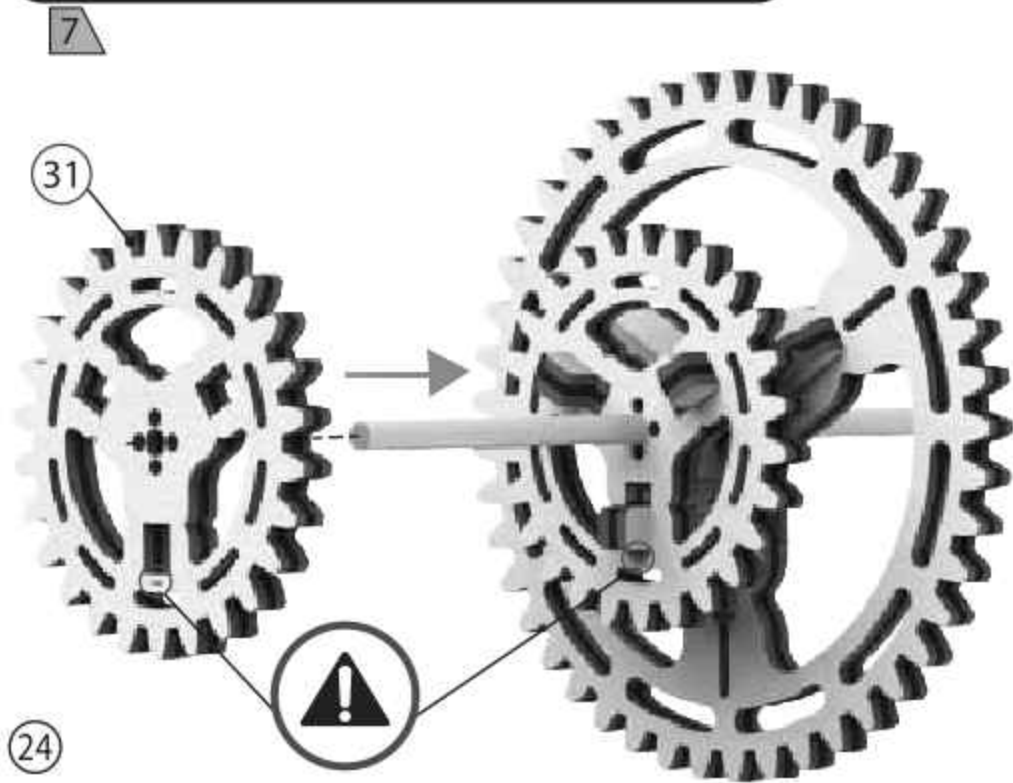
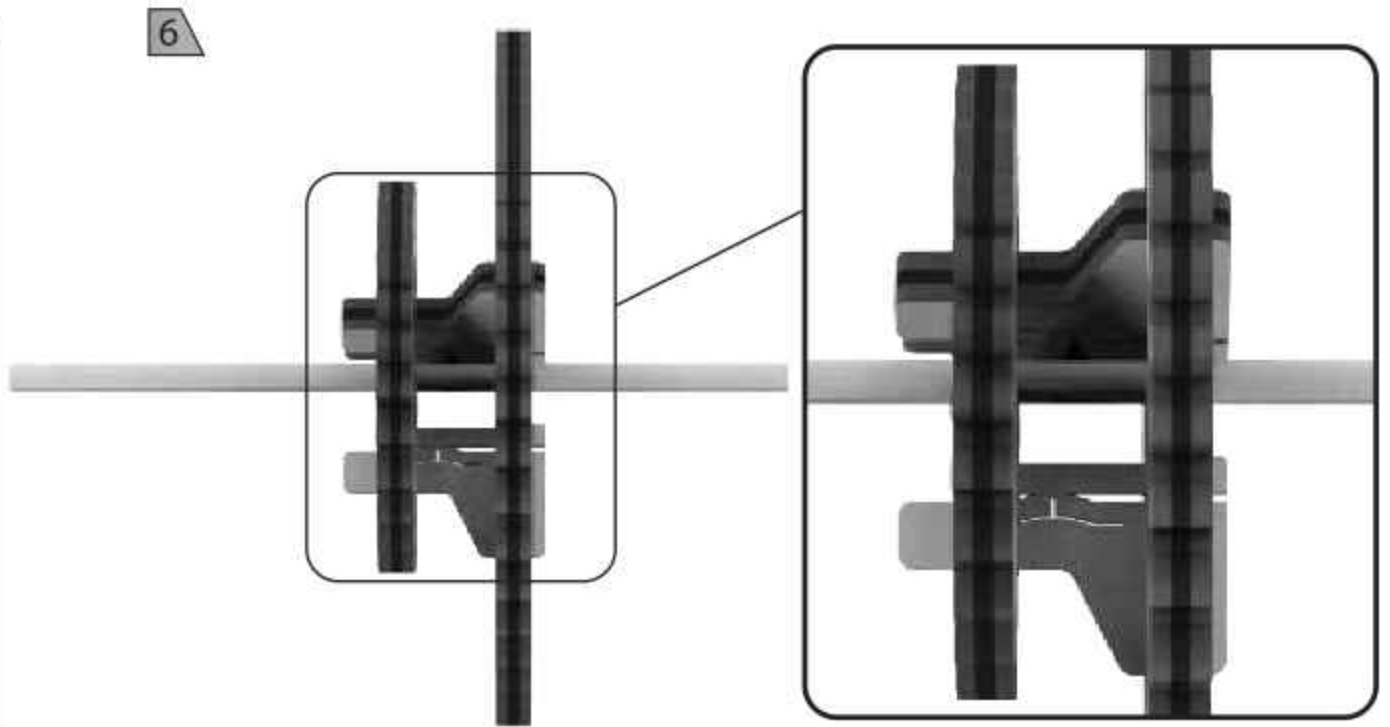
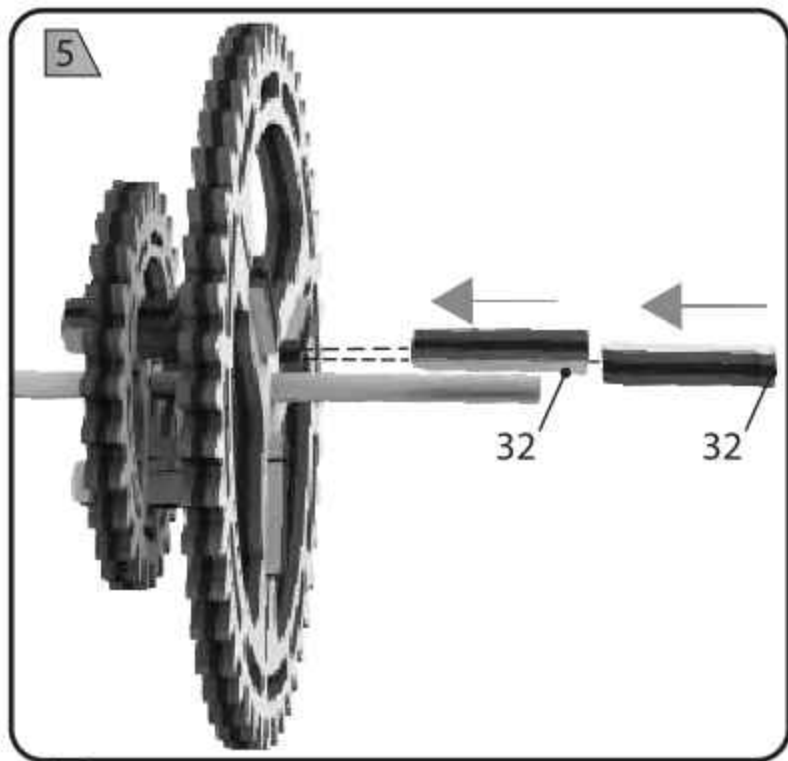

9

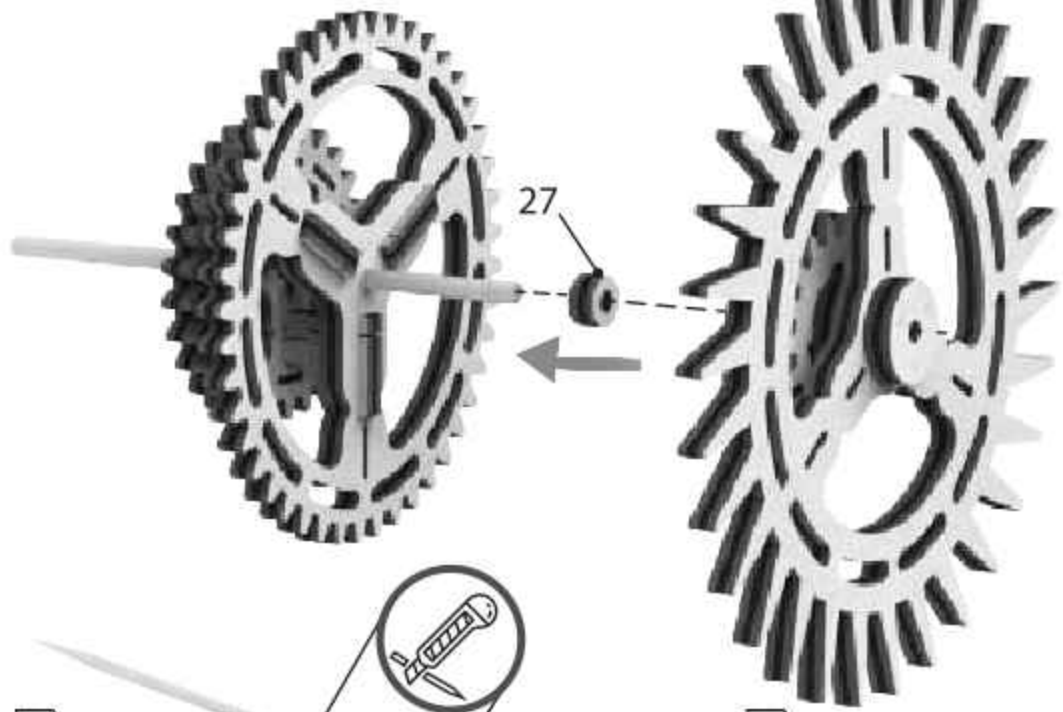

10

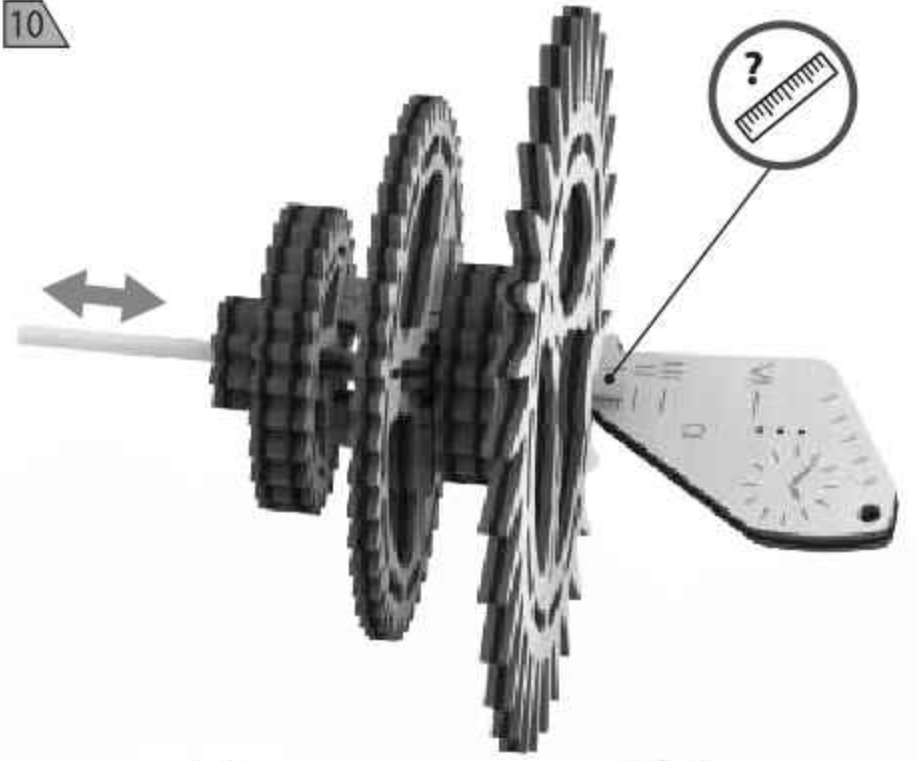

11

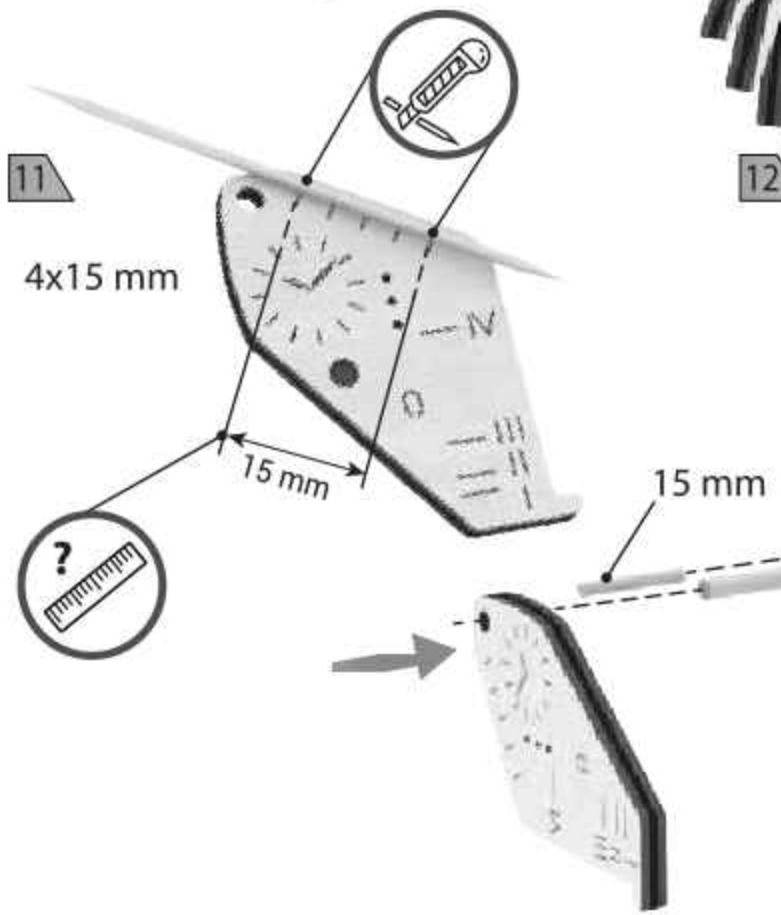

12

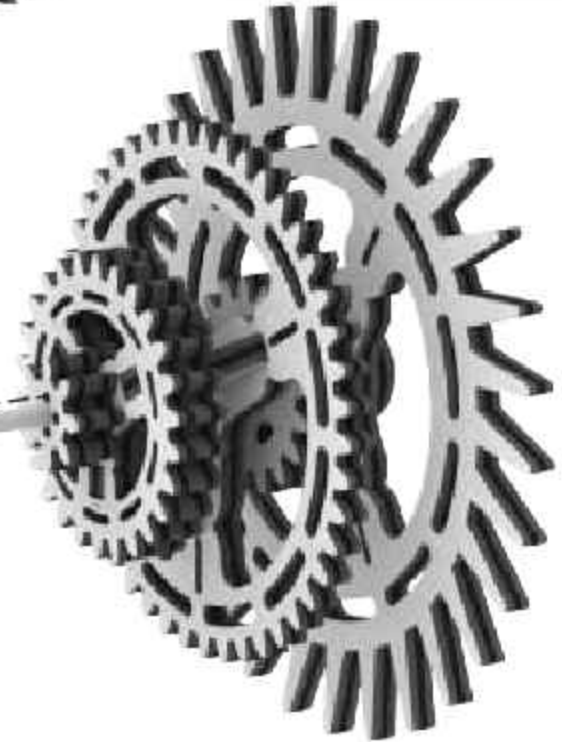

13

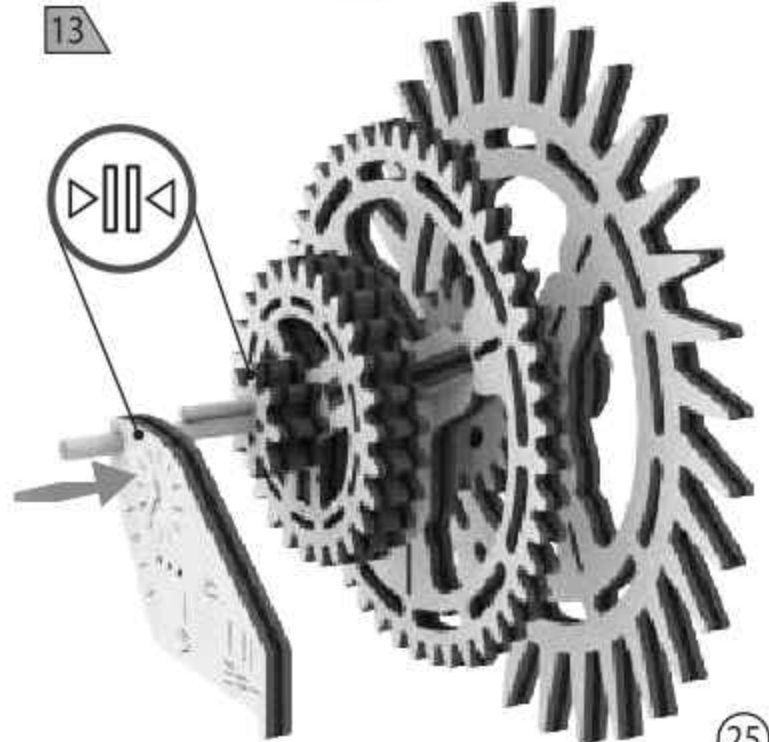

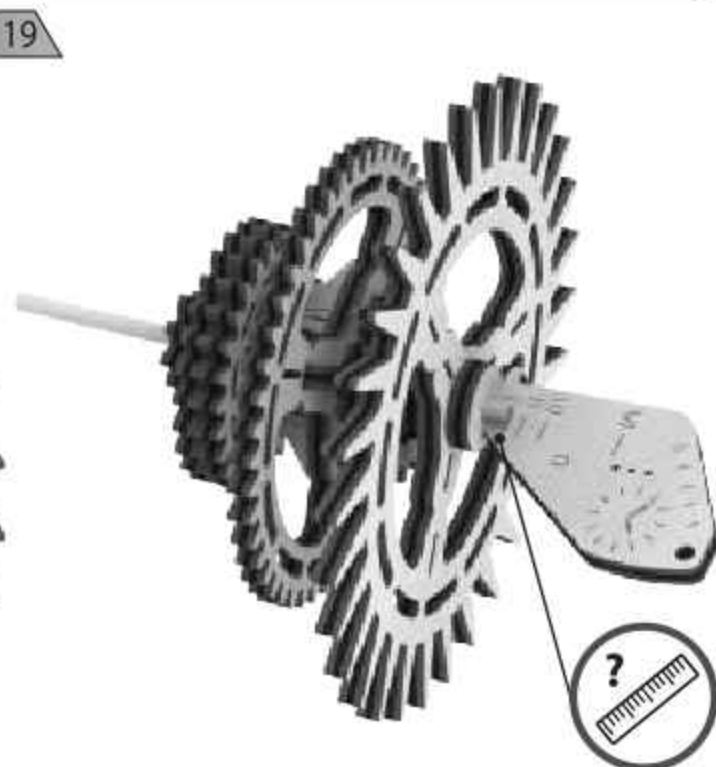
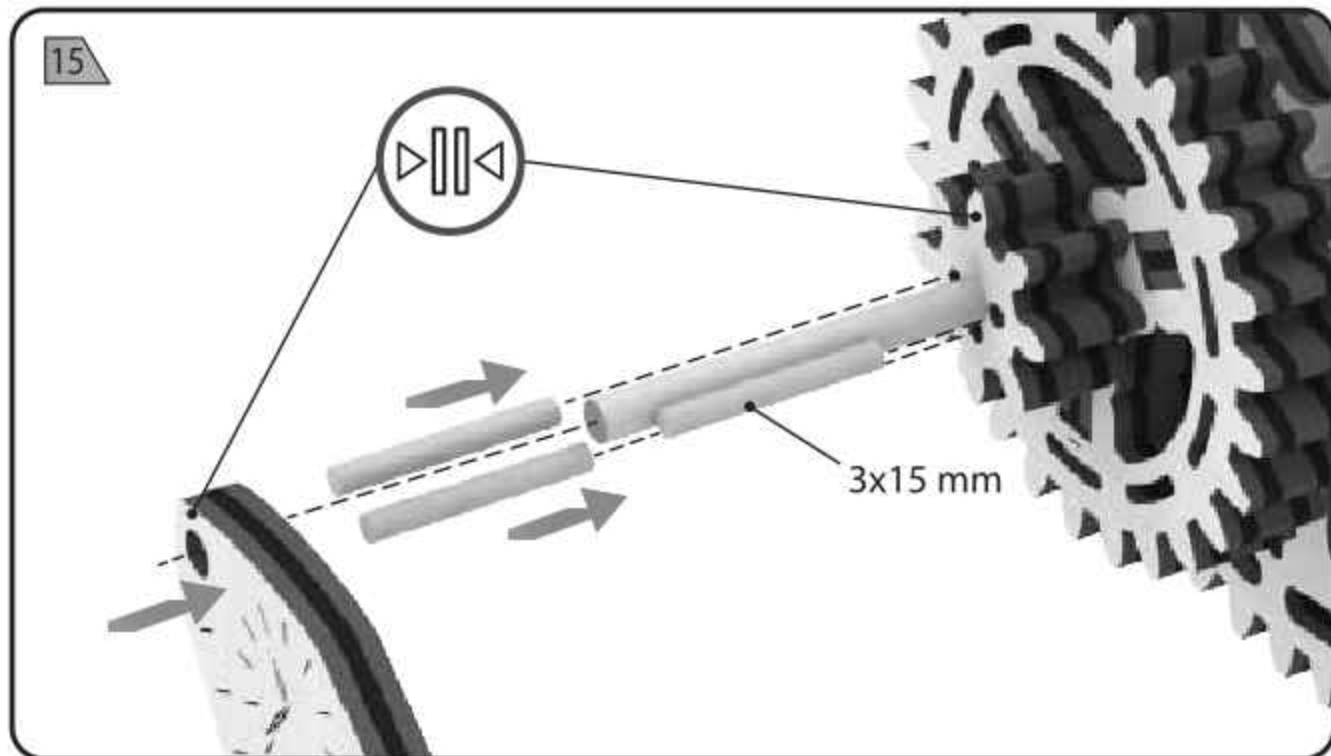
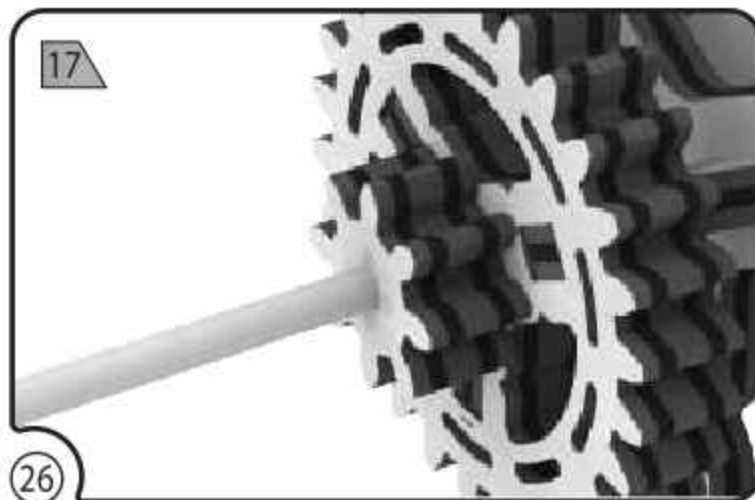
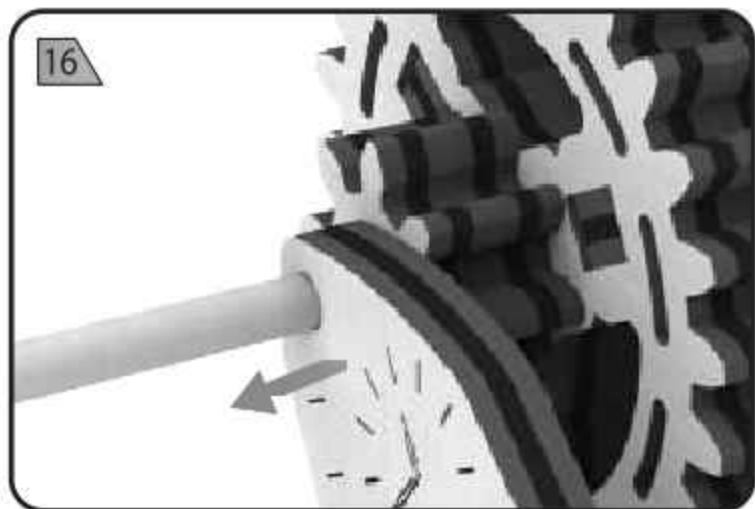
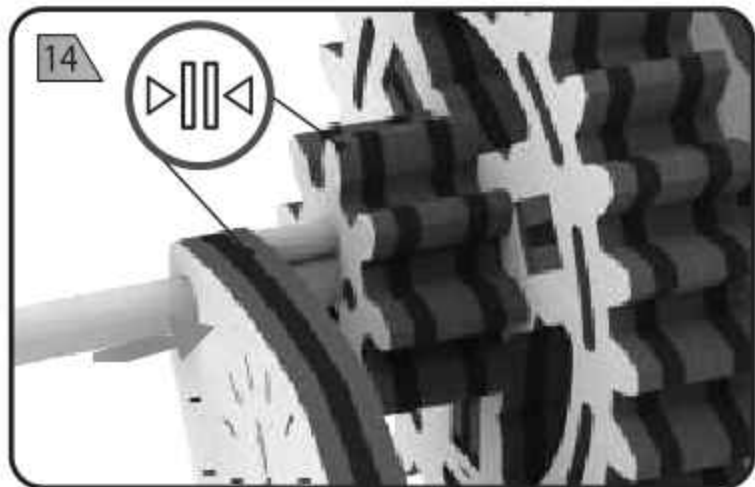

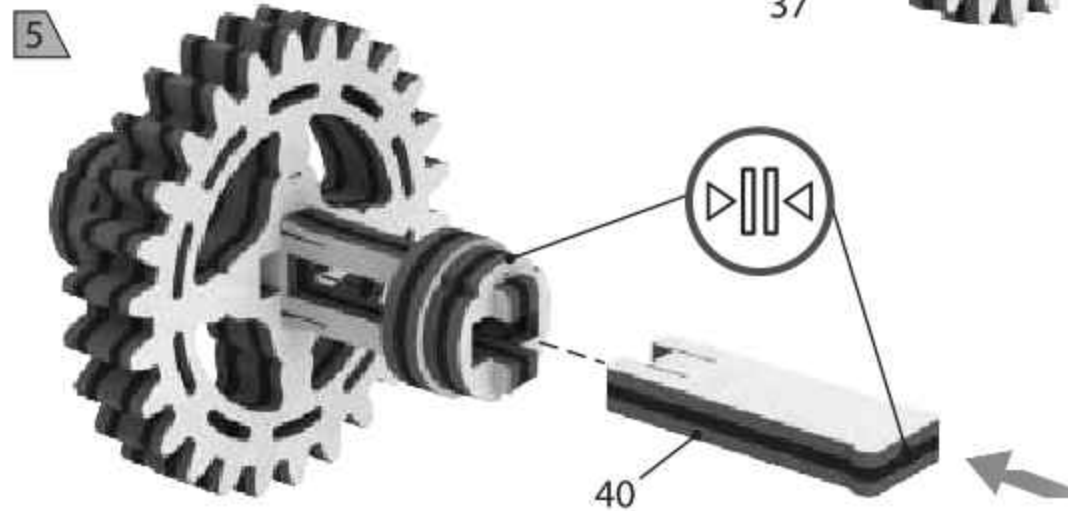
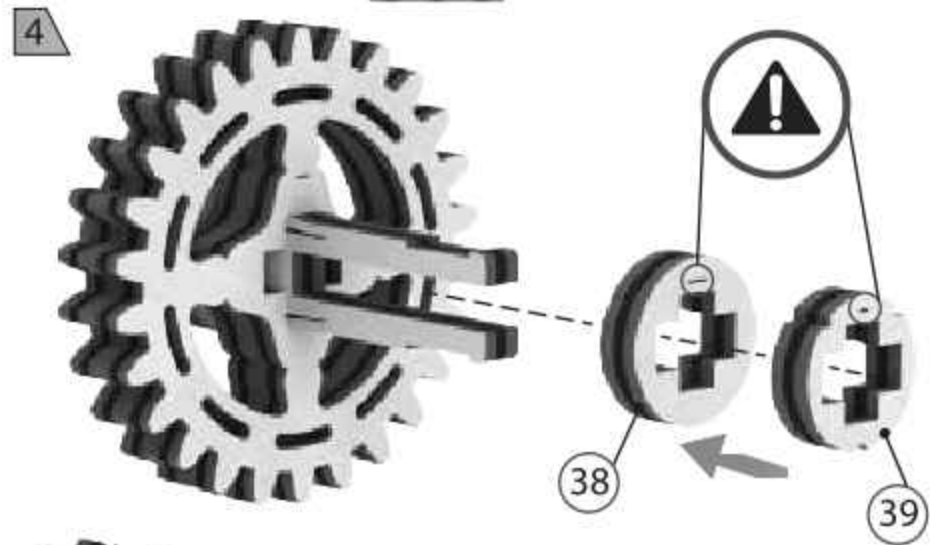
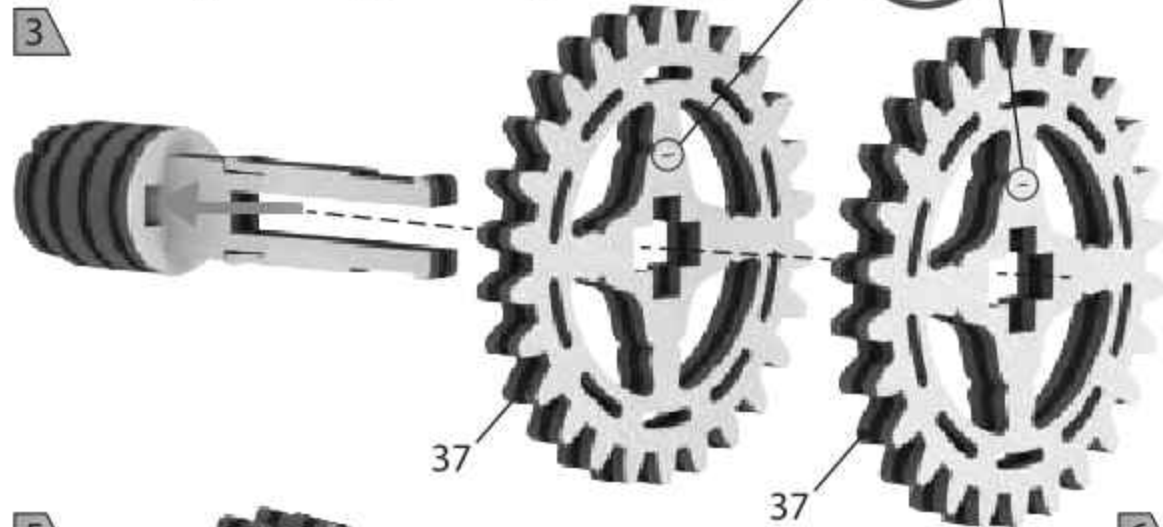
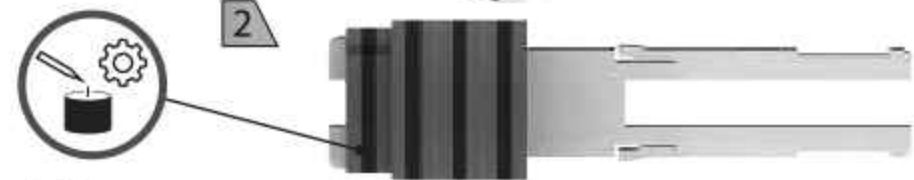
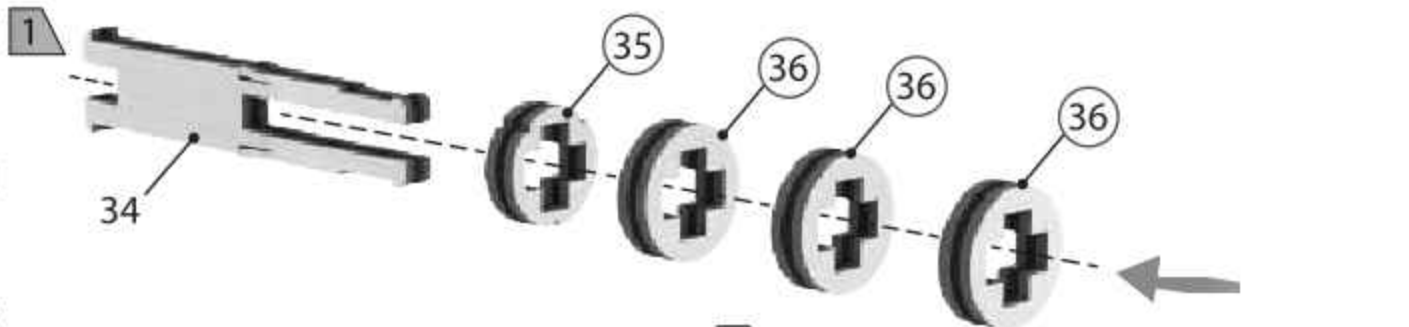
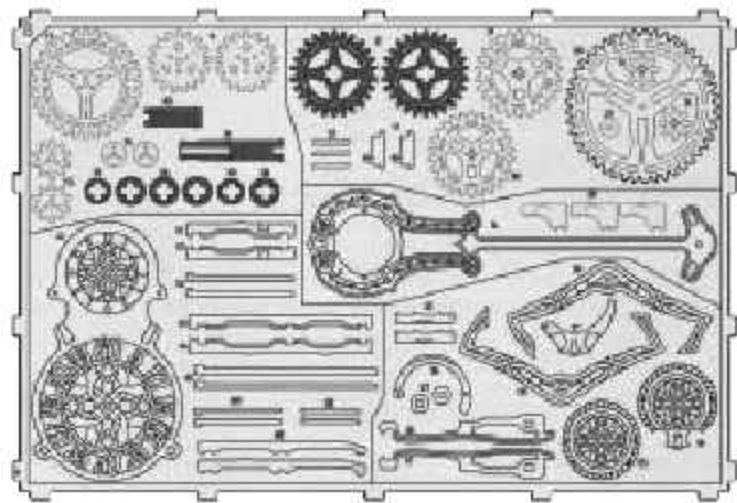



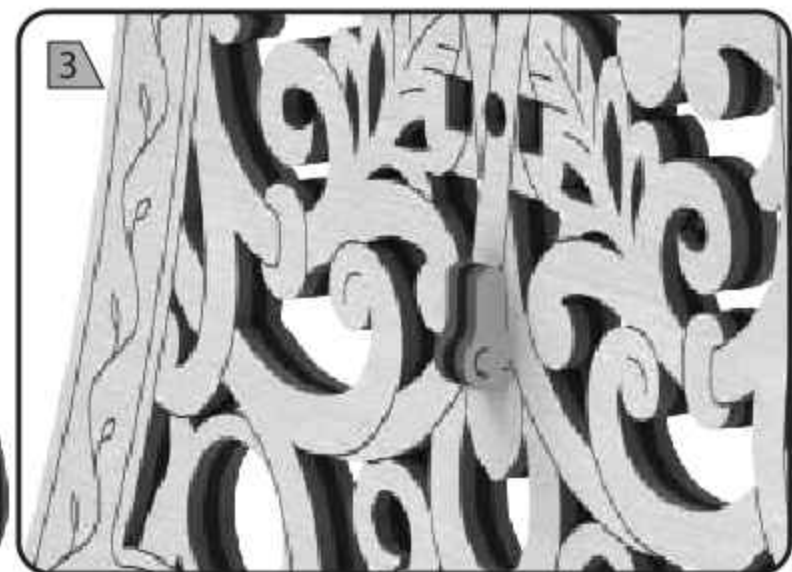
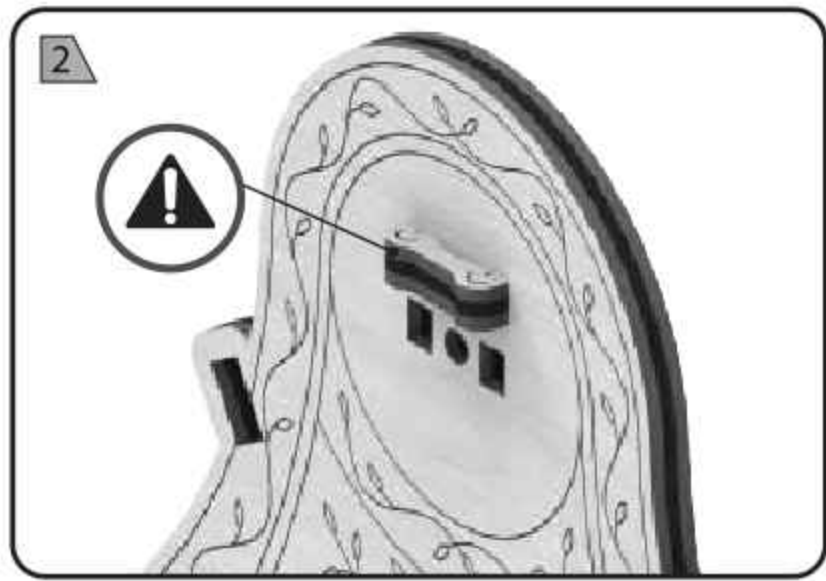
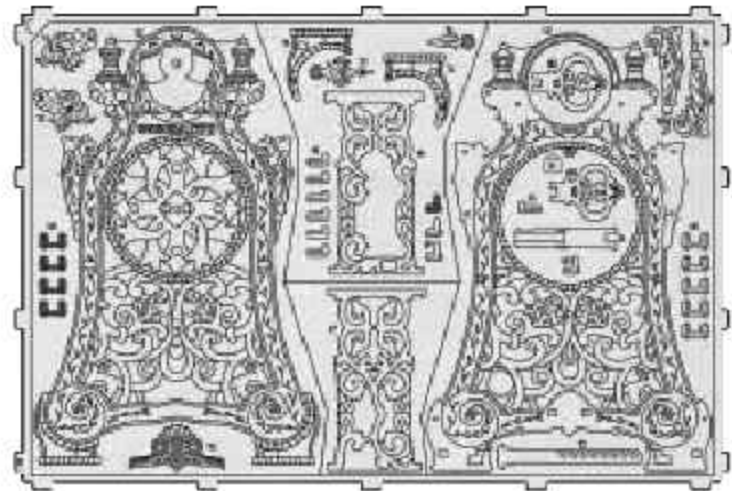
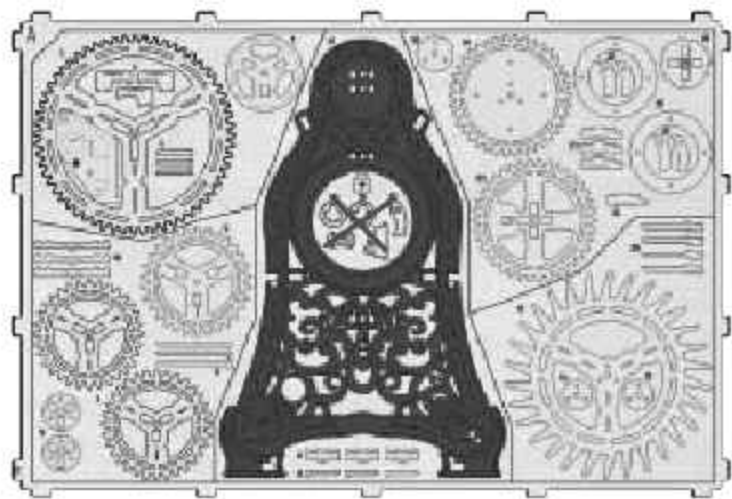



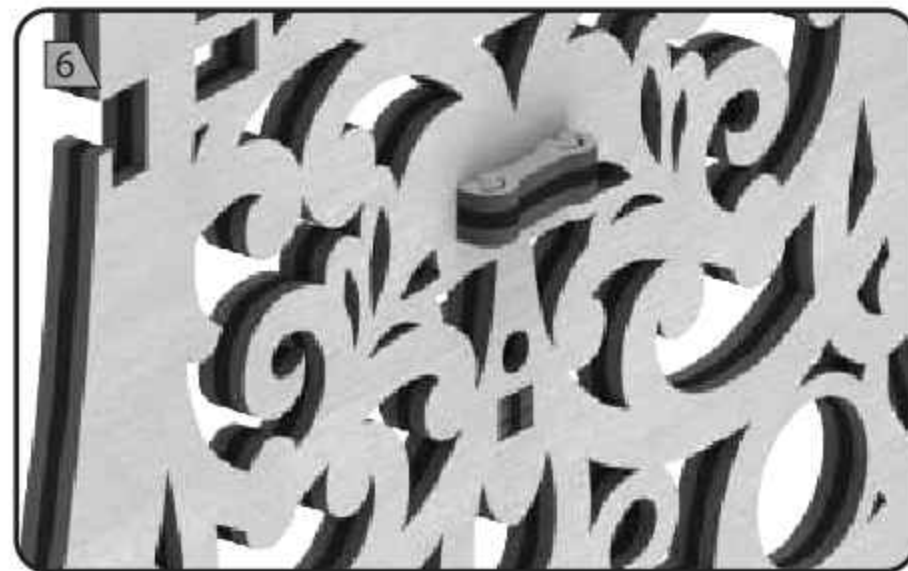
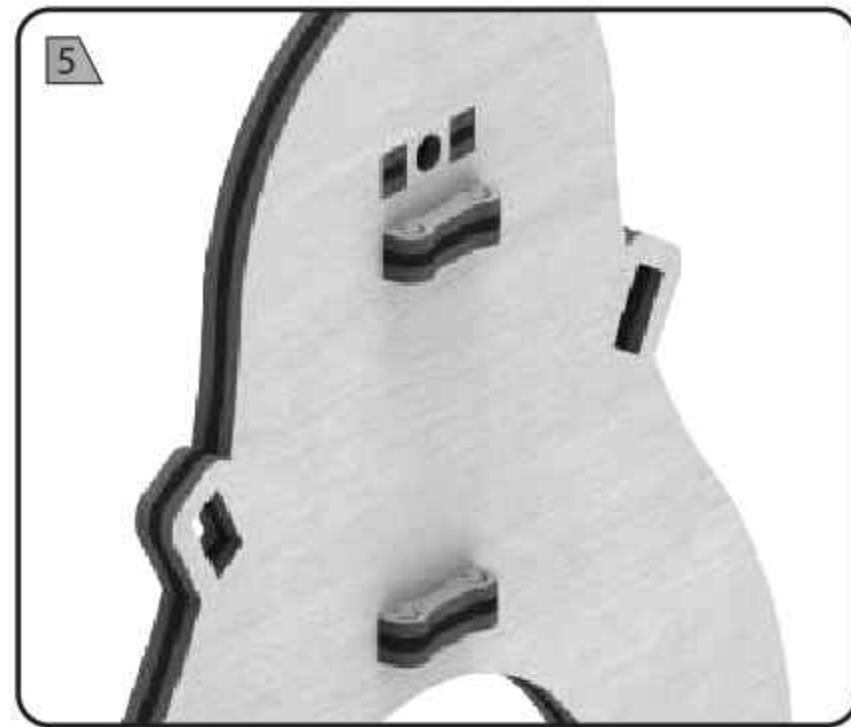
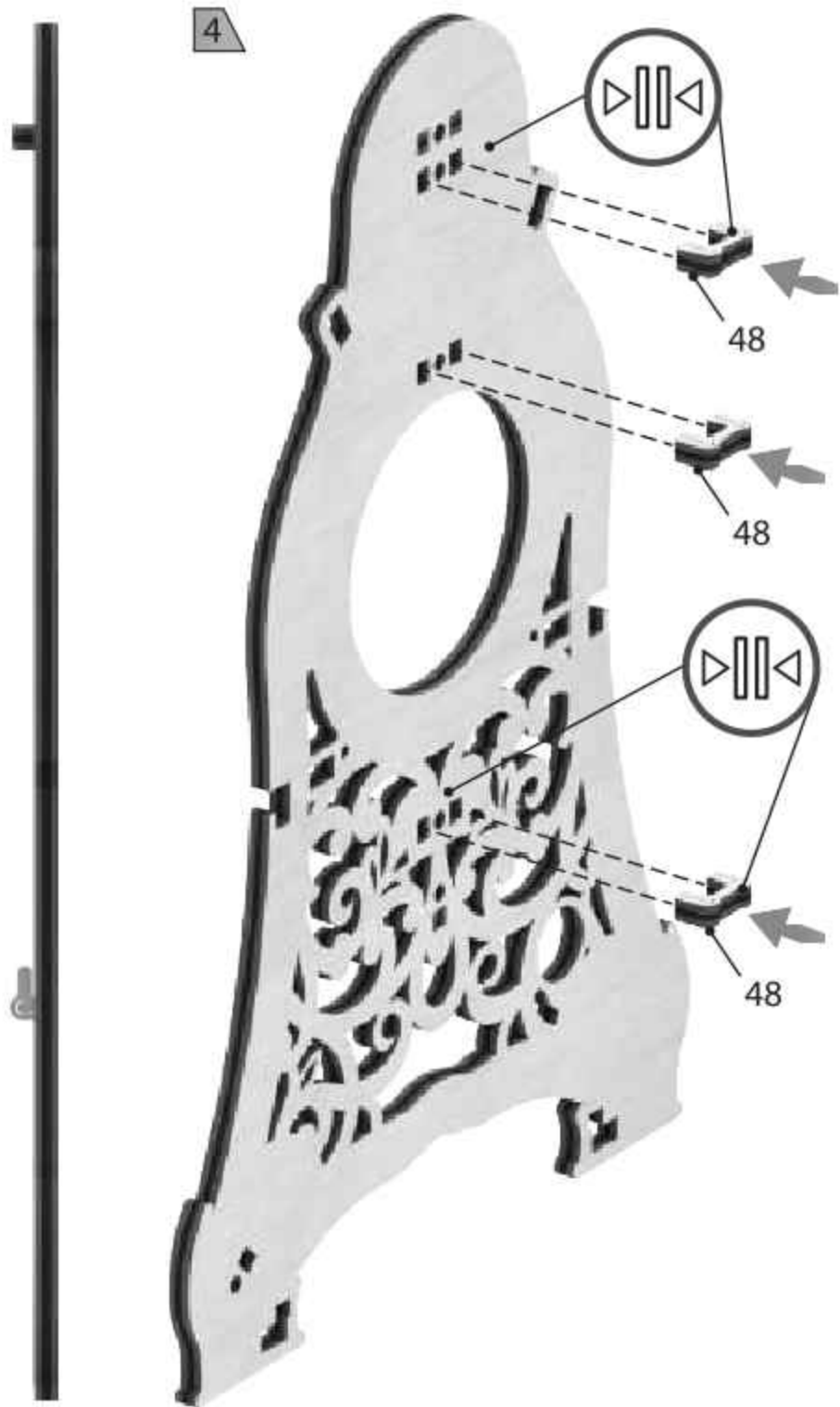

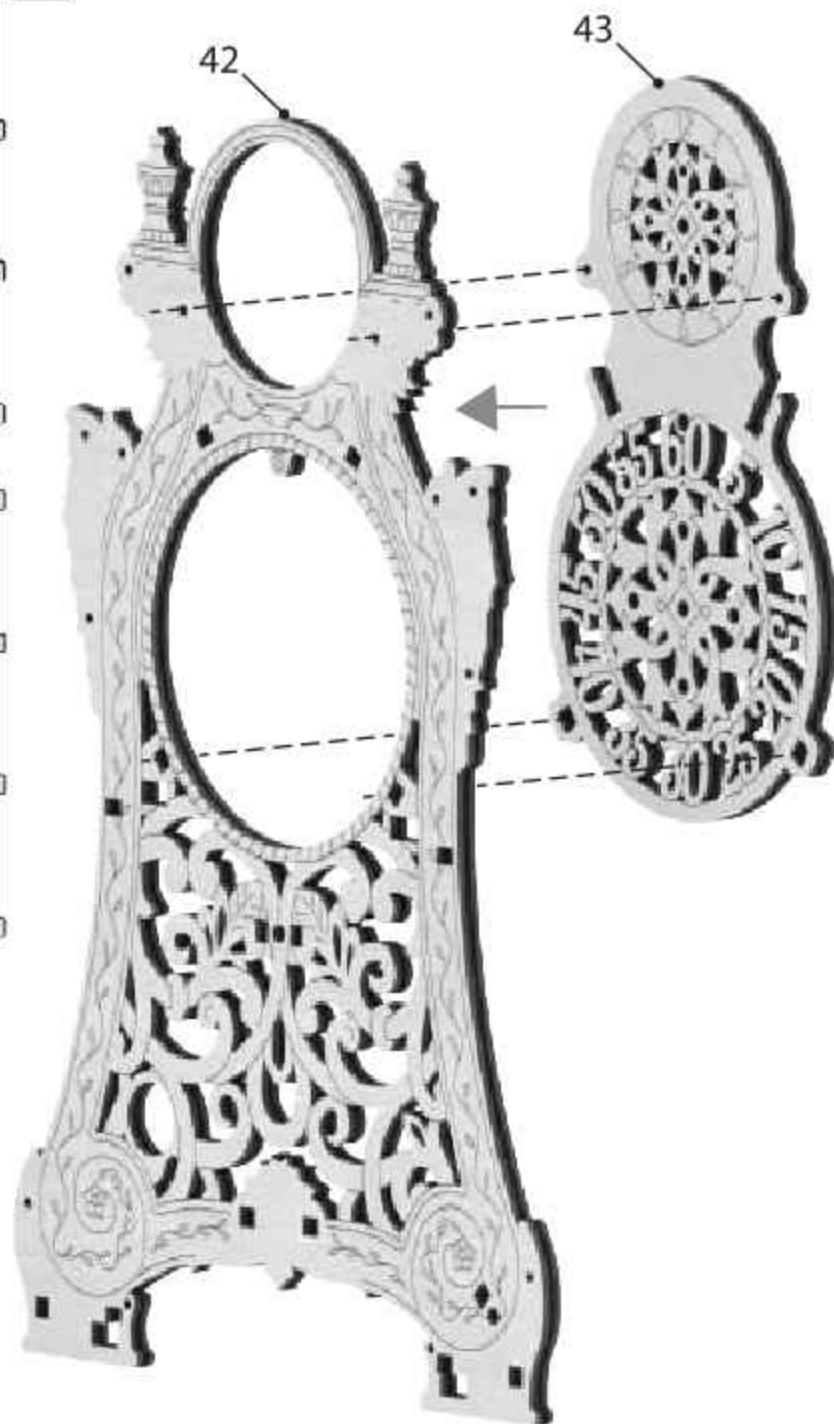
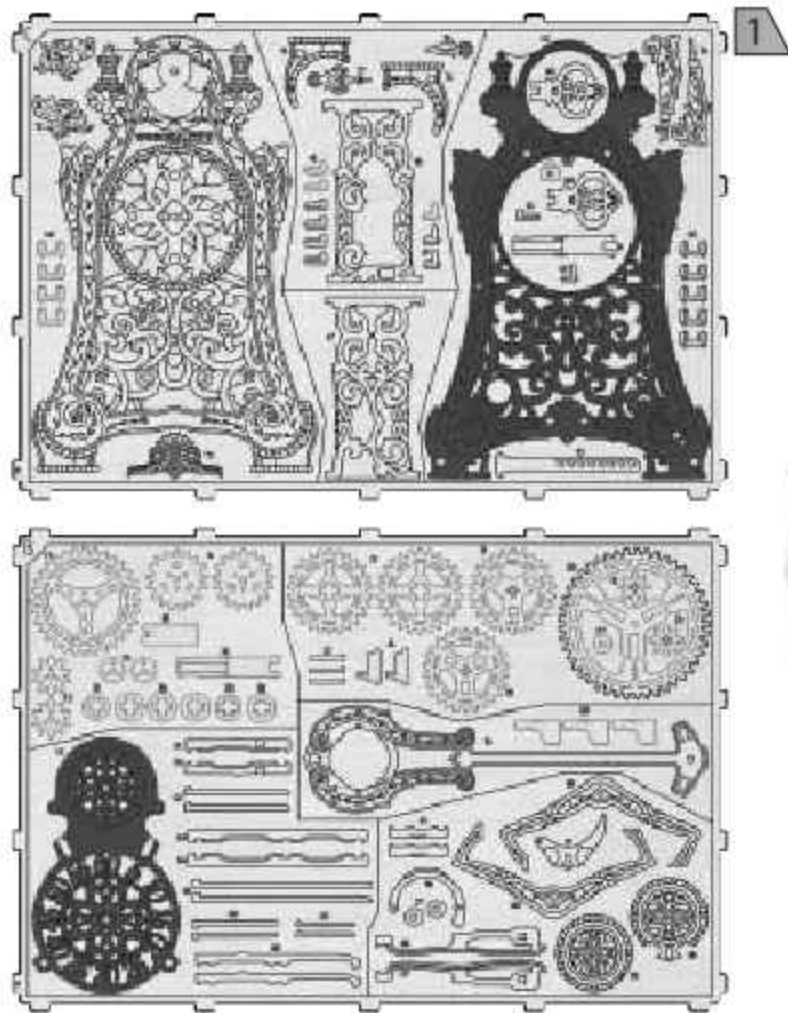

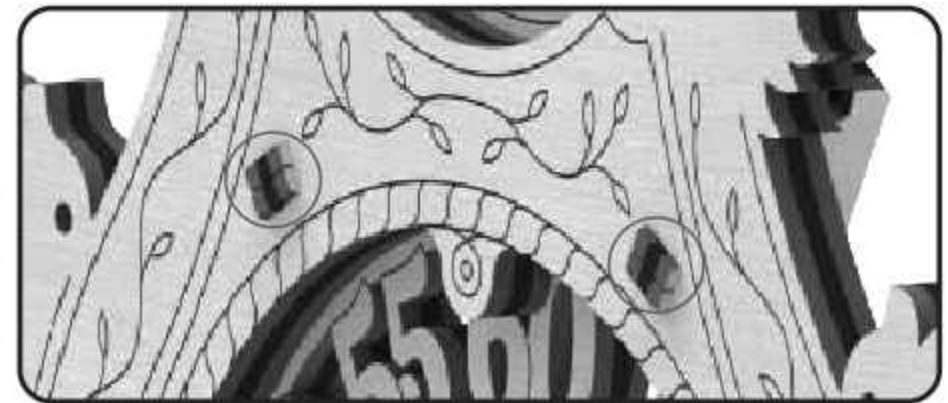
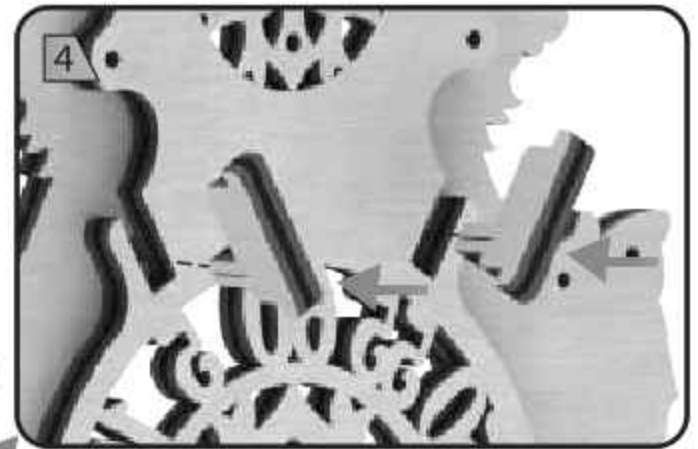
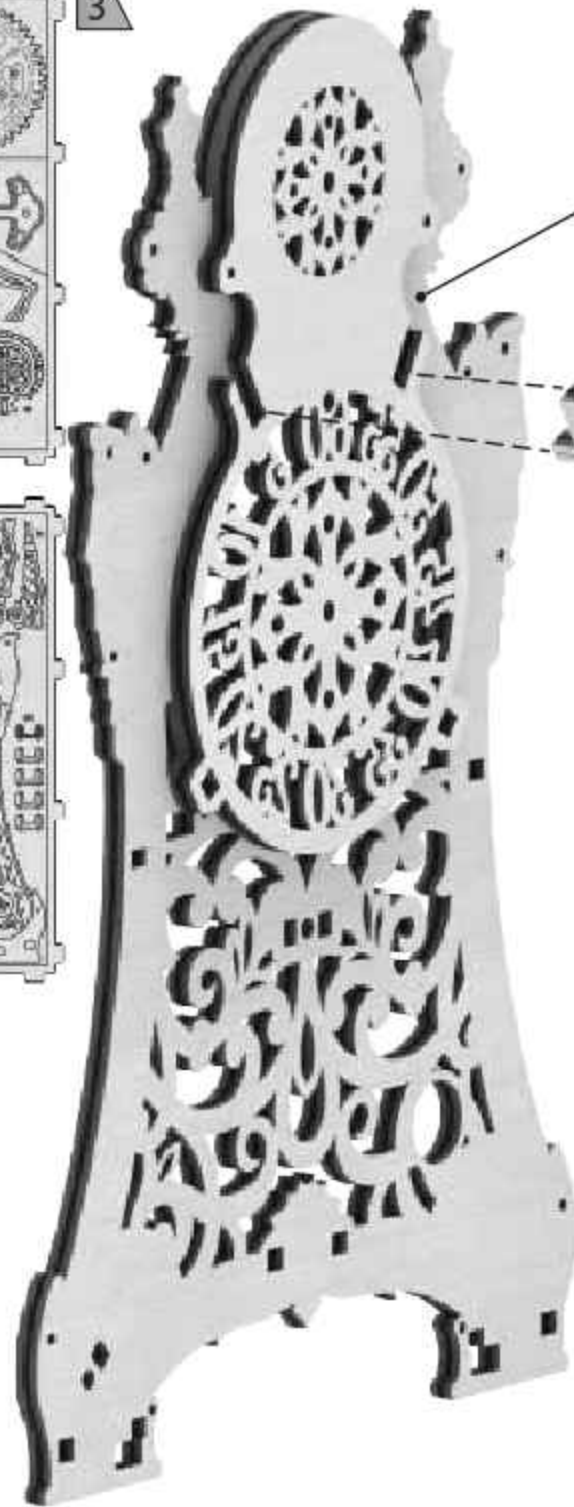
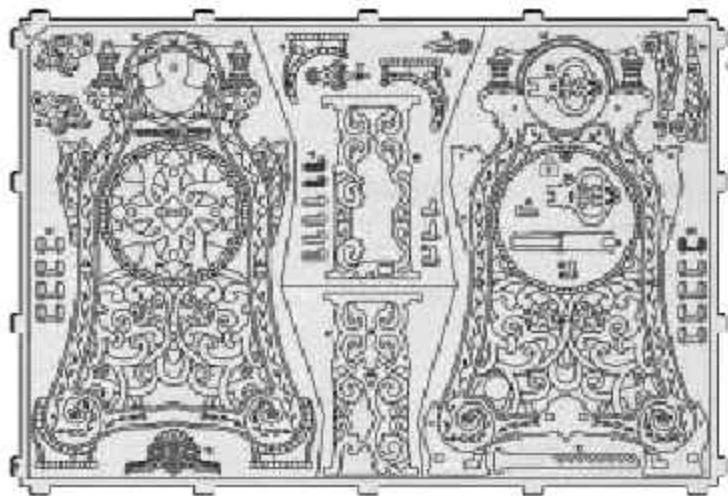
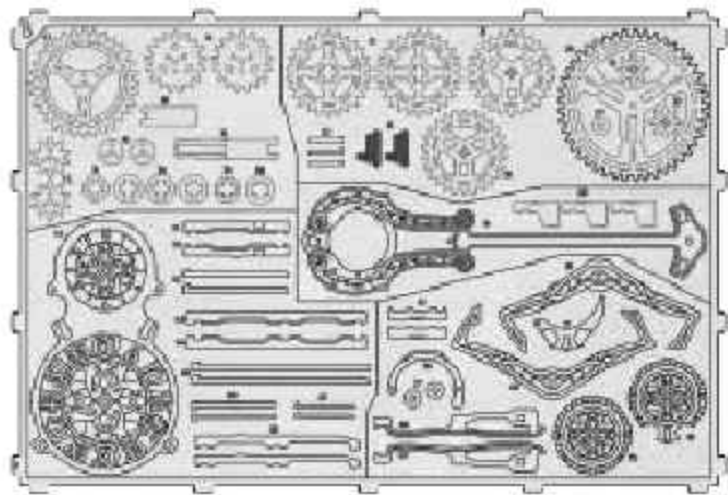

6

32

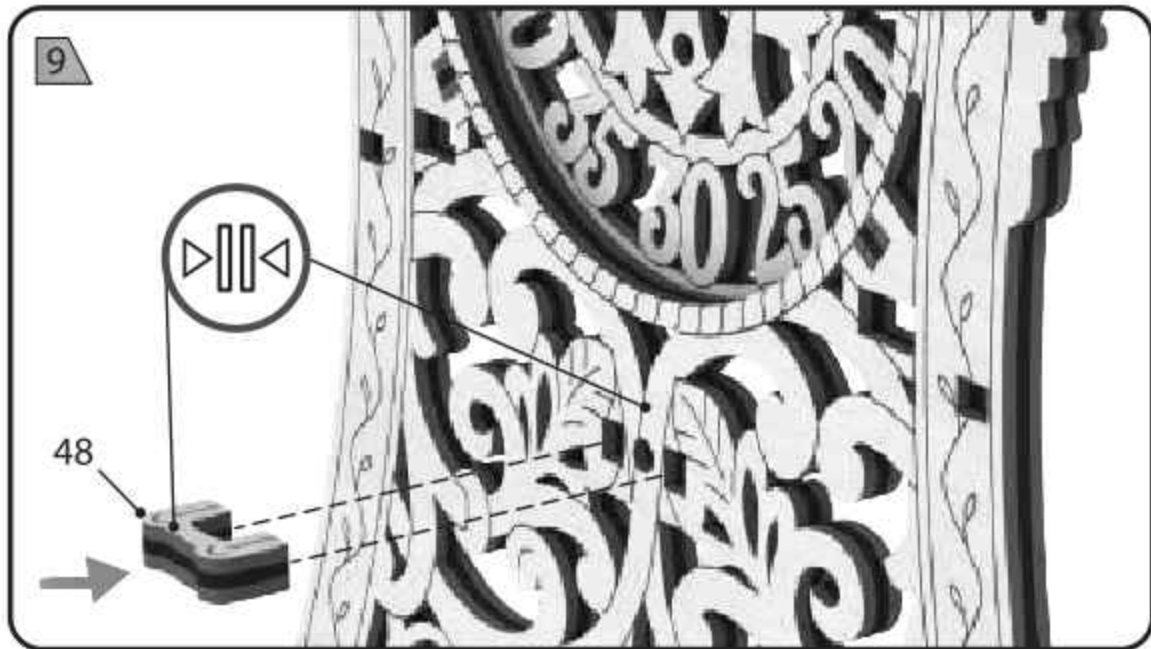
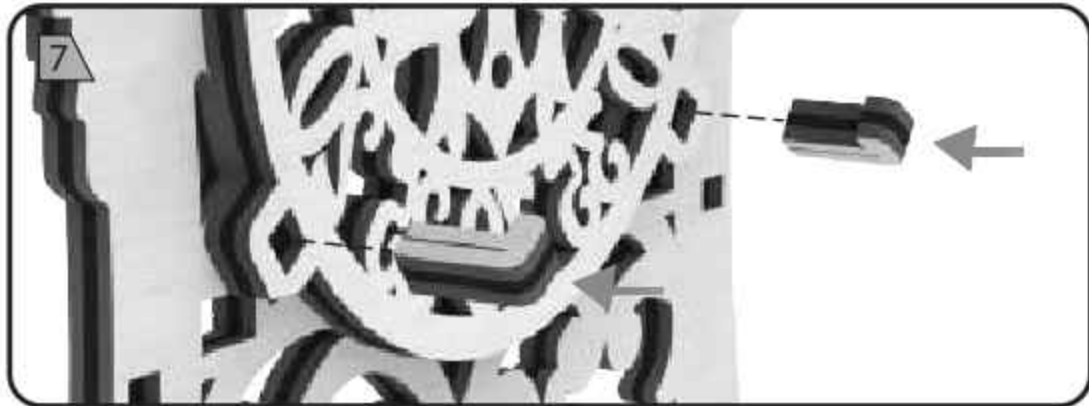
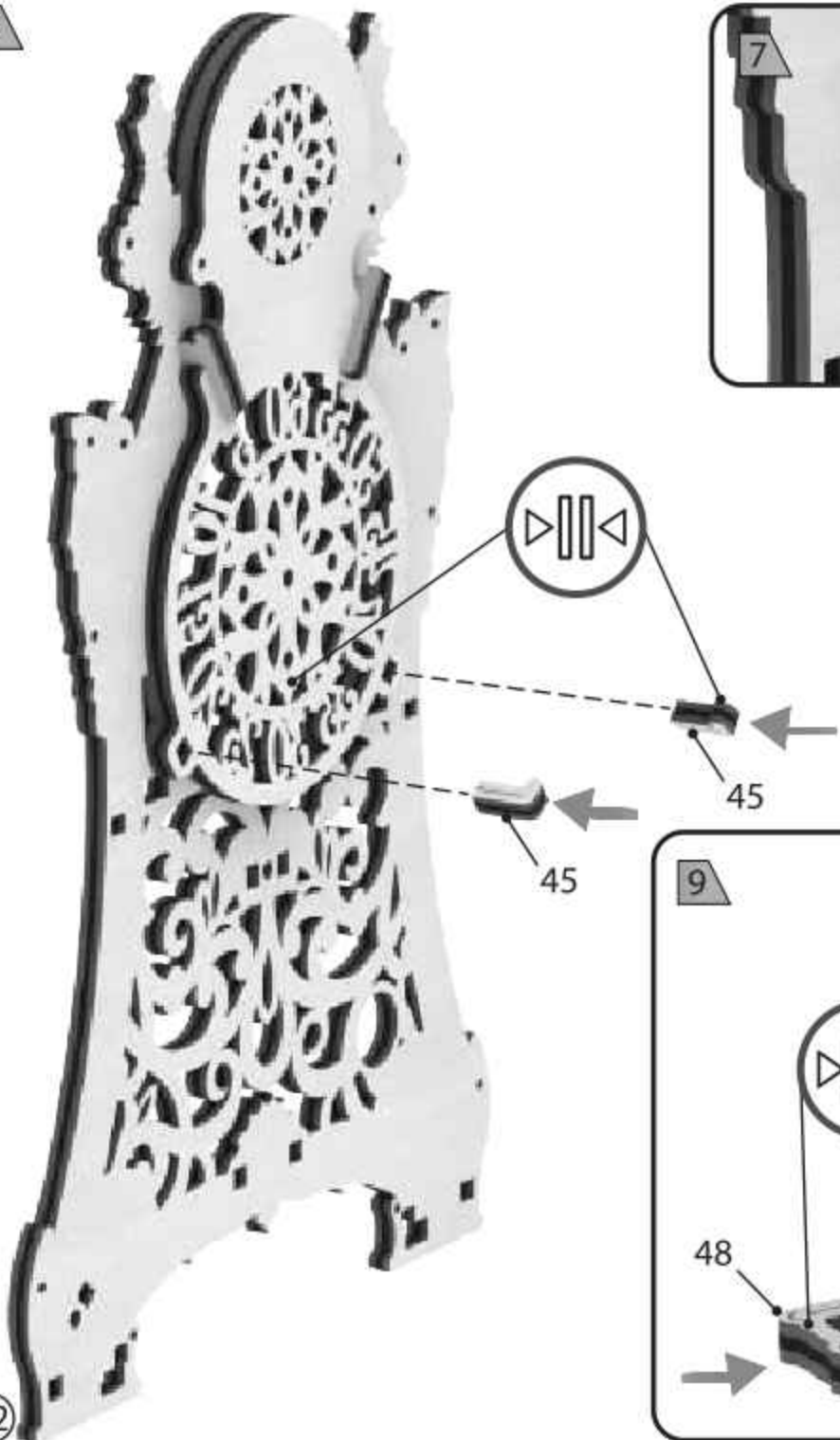



1

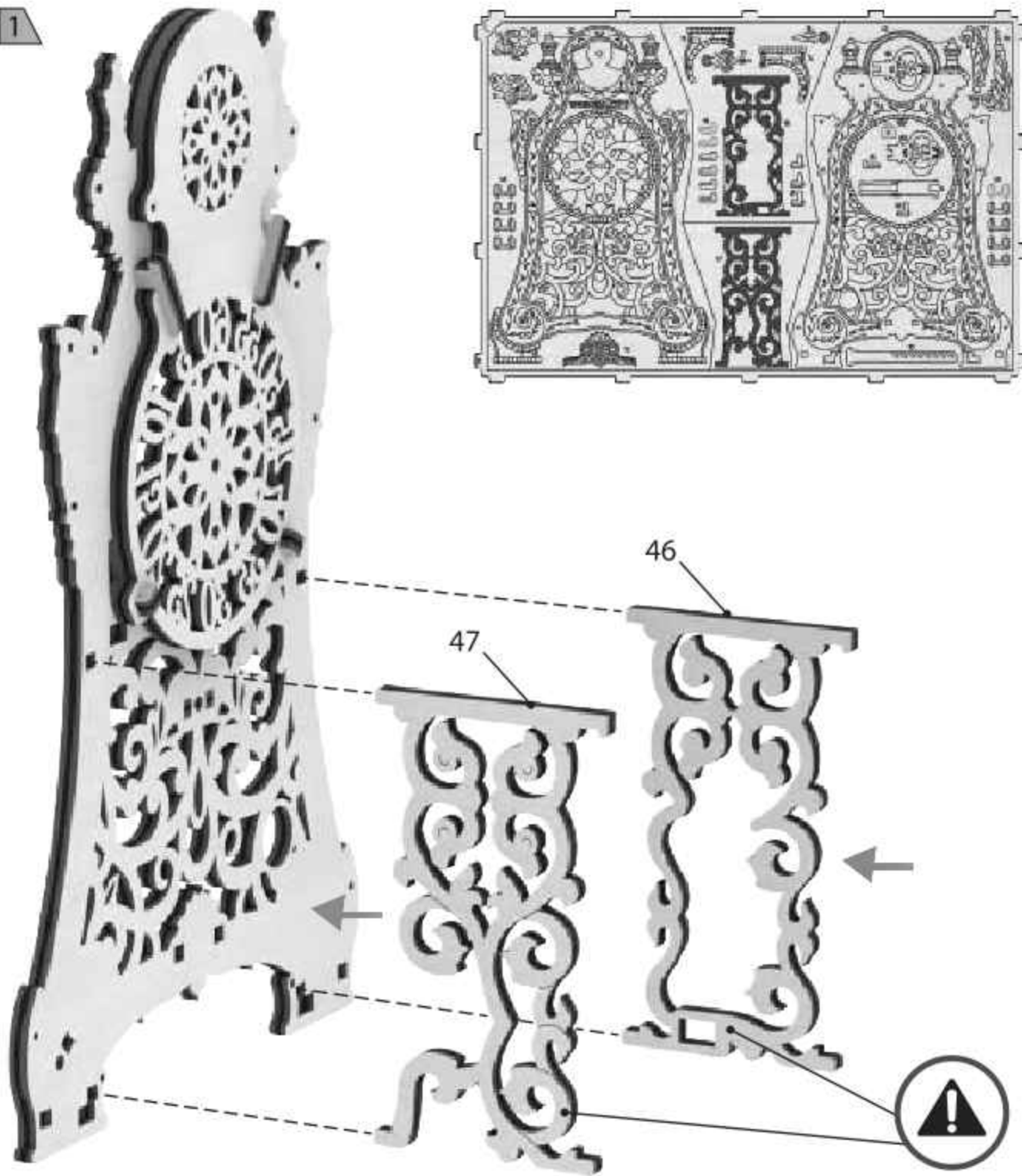

2

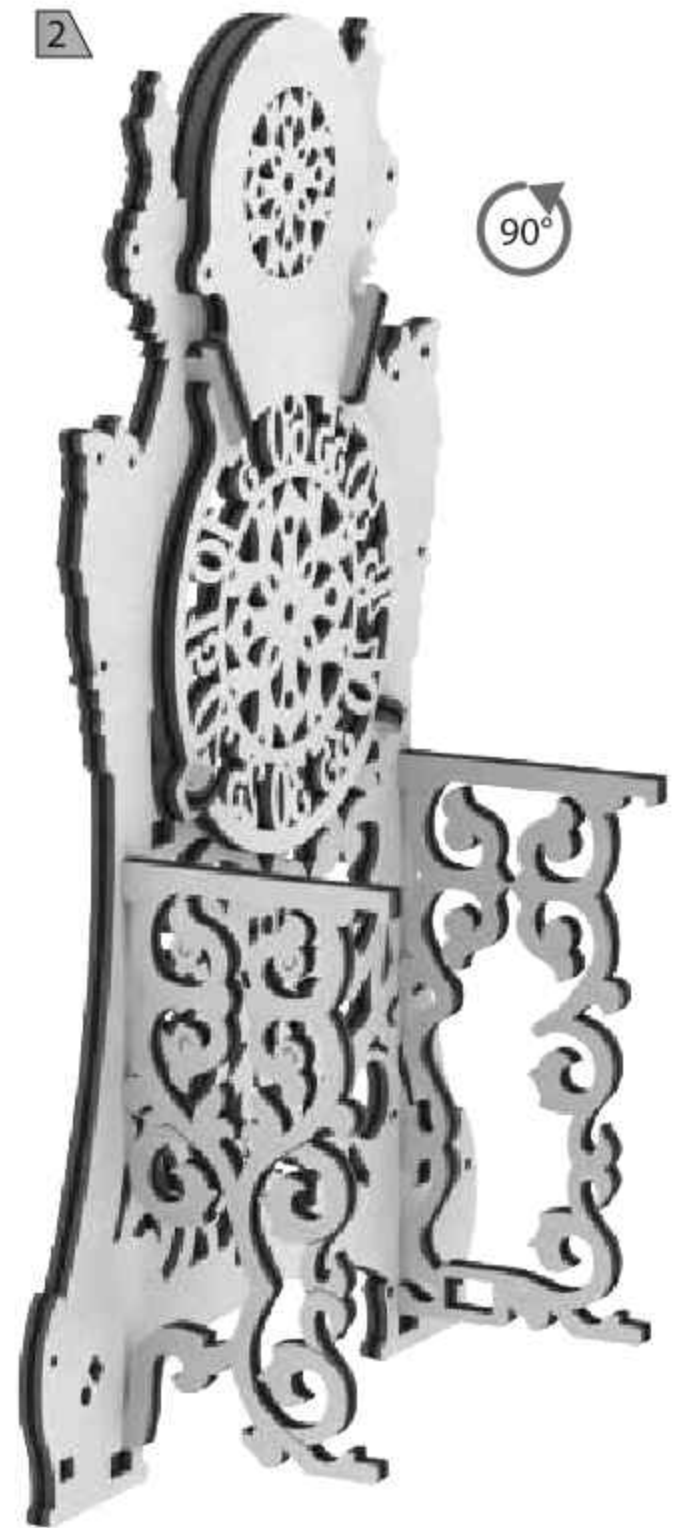



FRONT



BACK

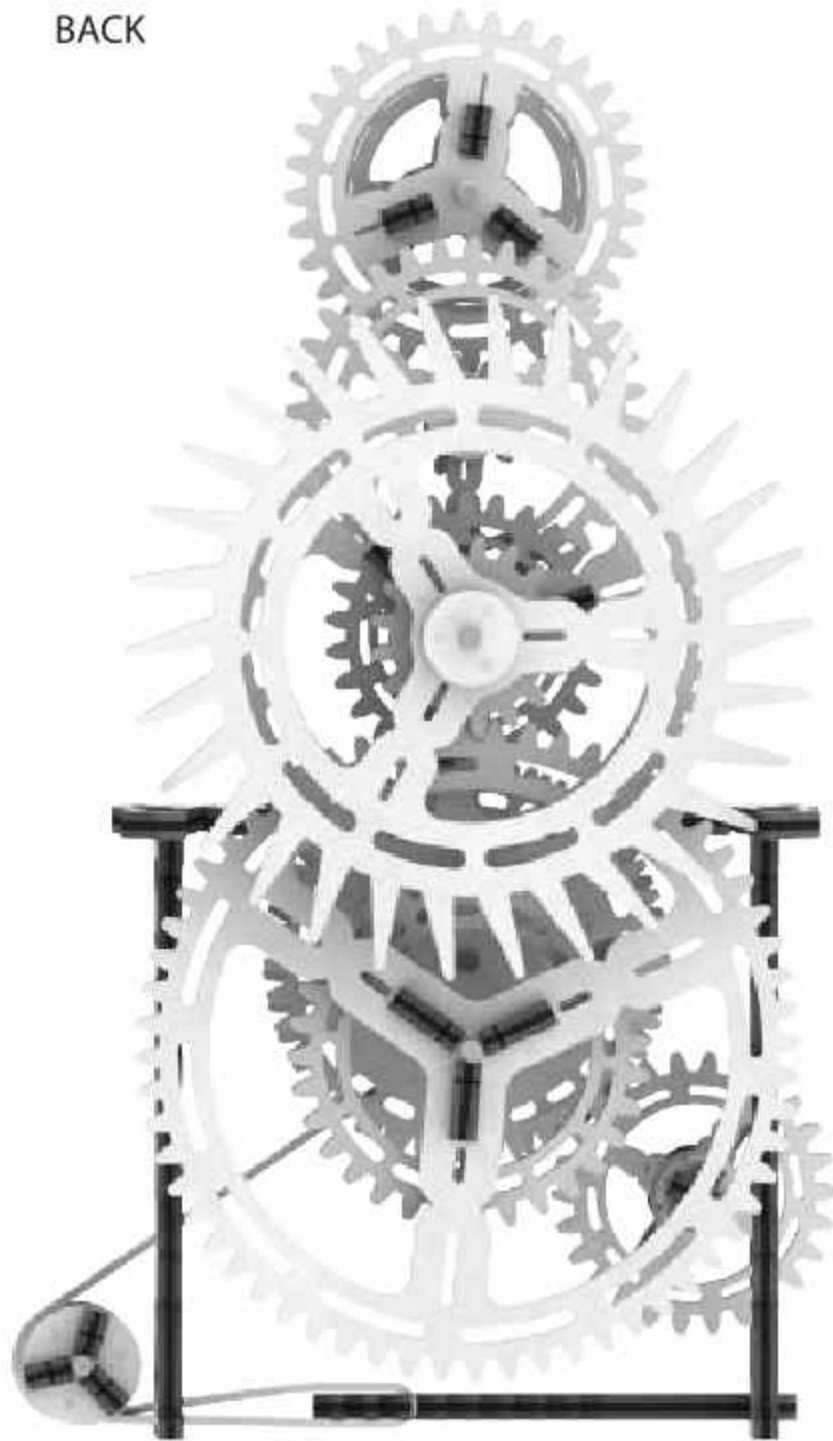
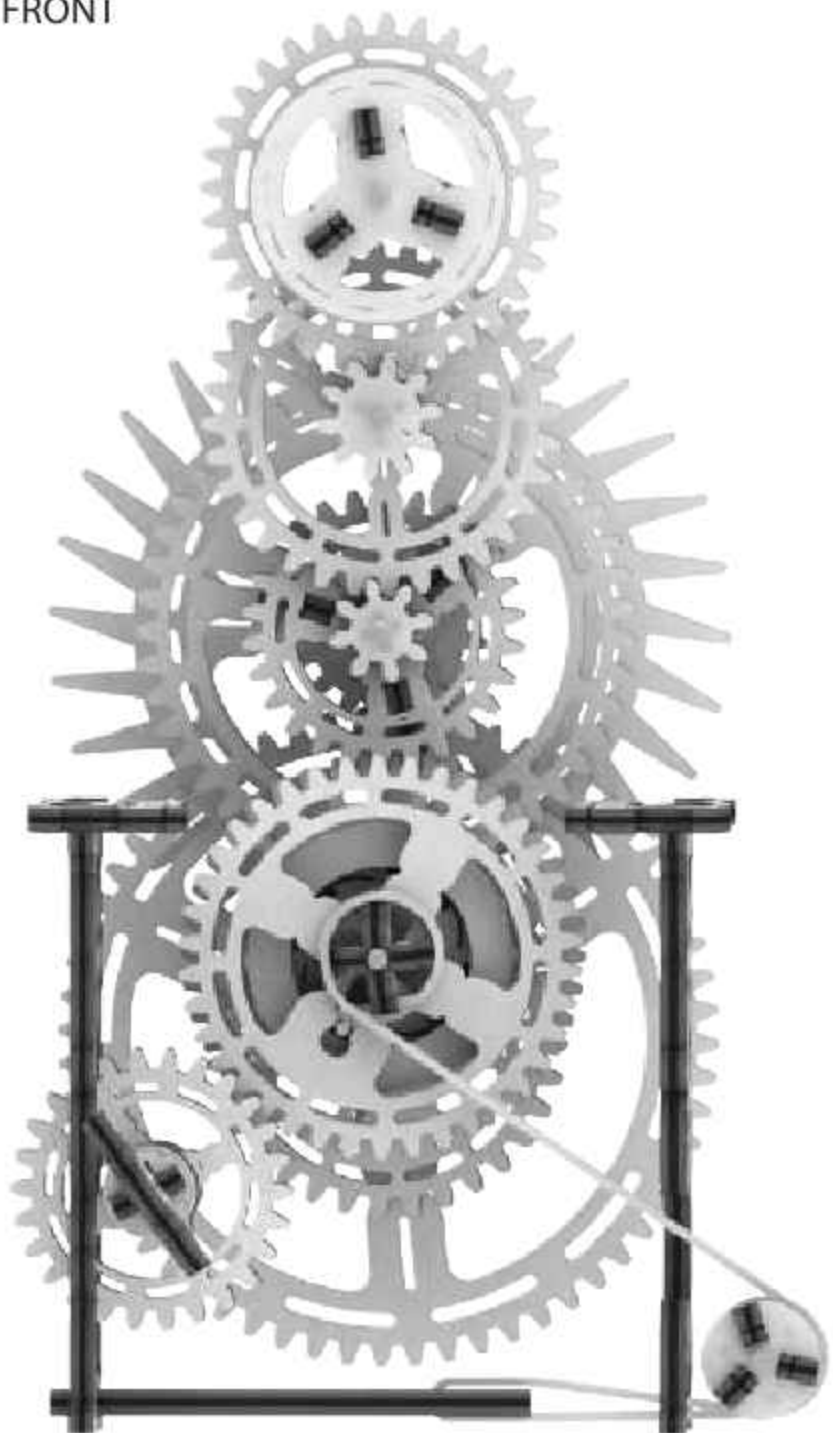

RIGHT



LEFT

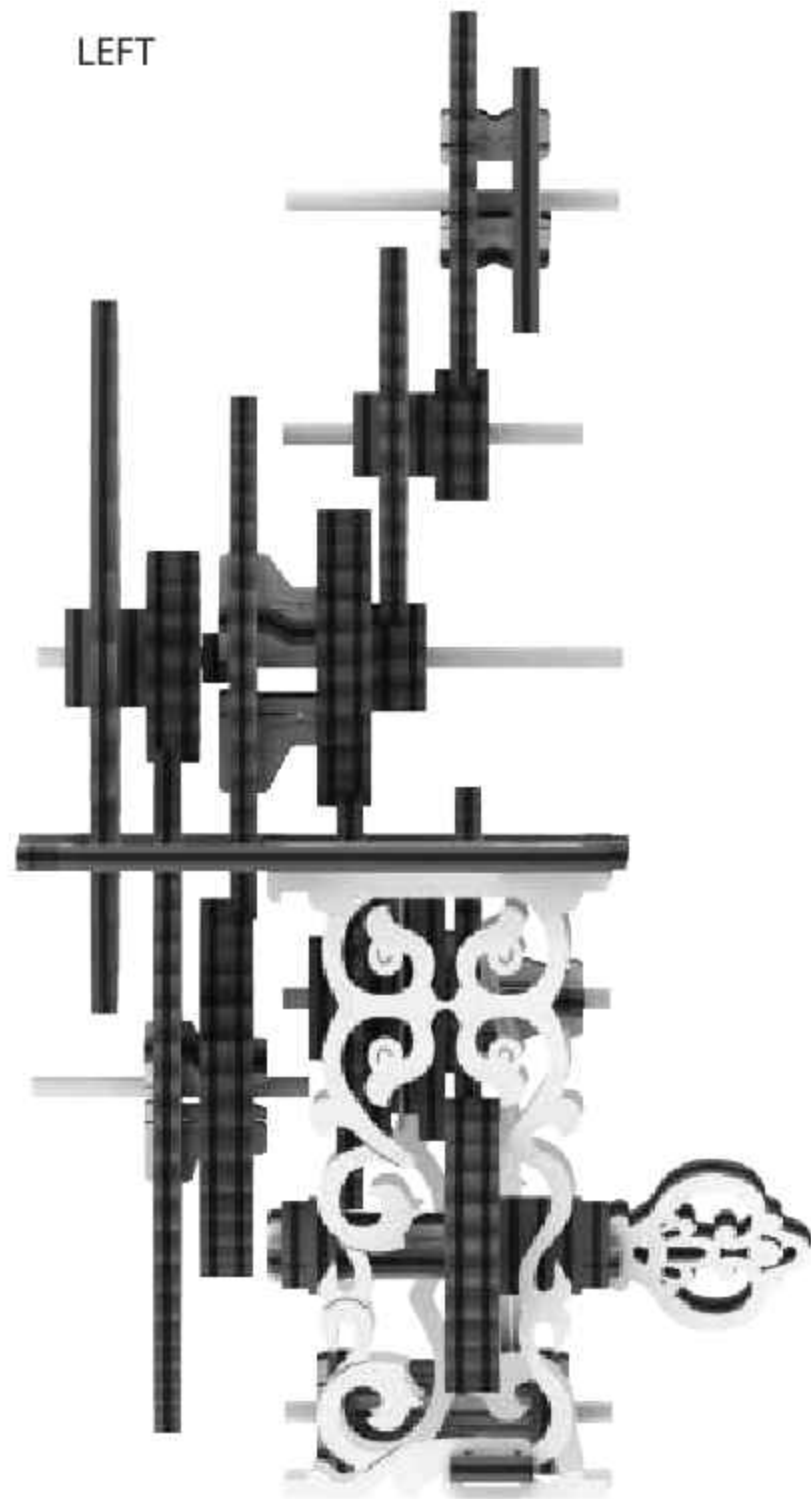
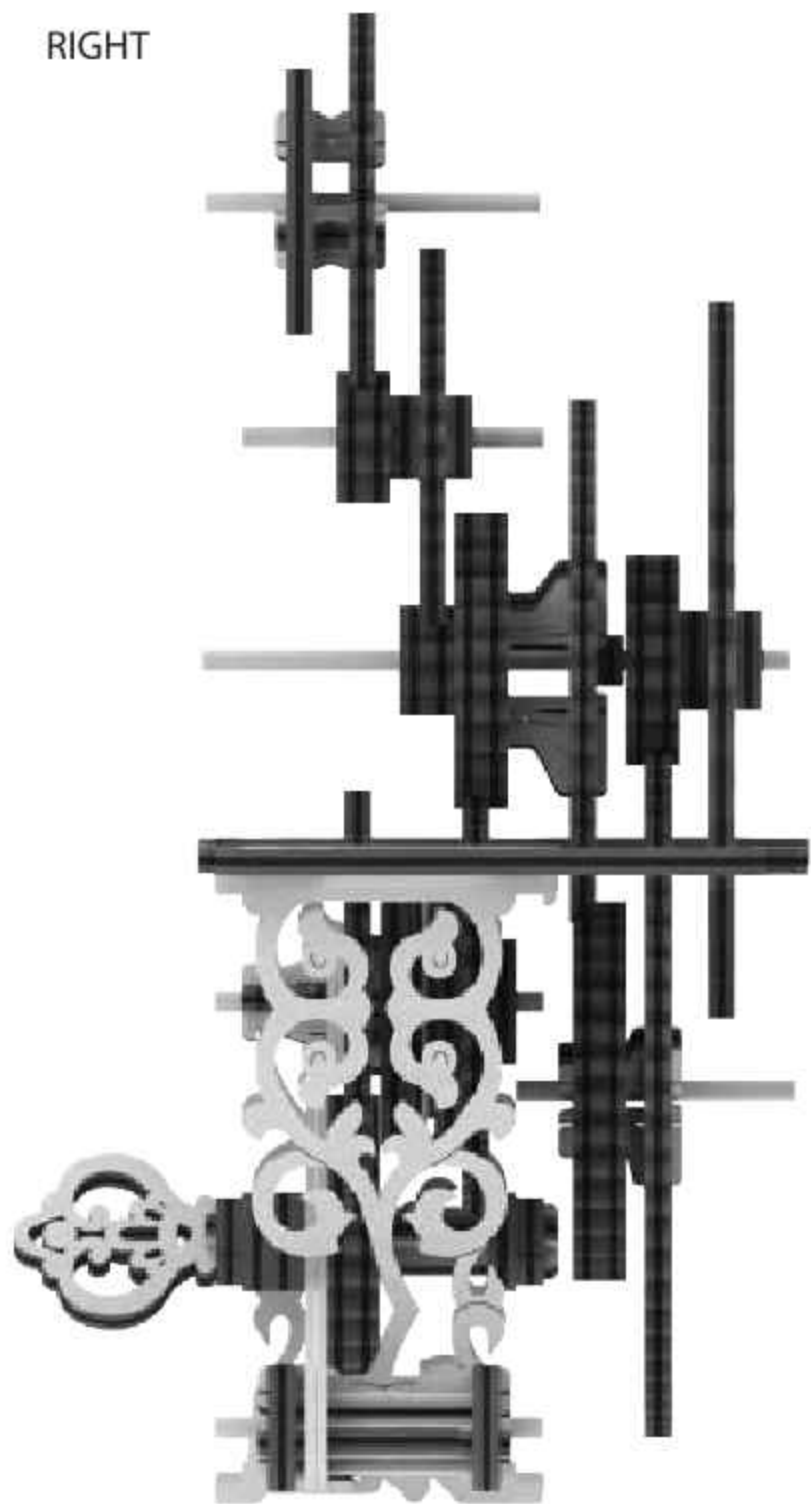

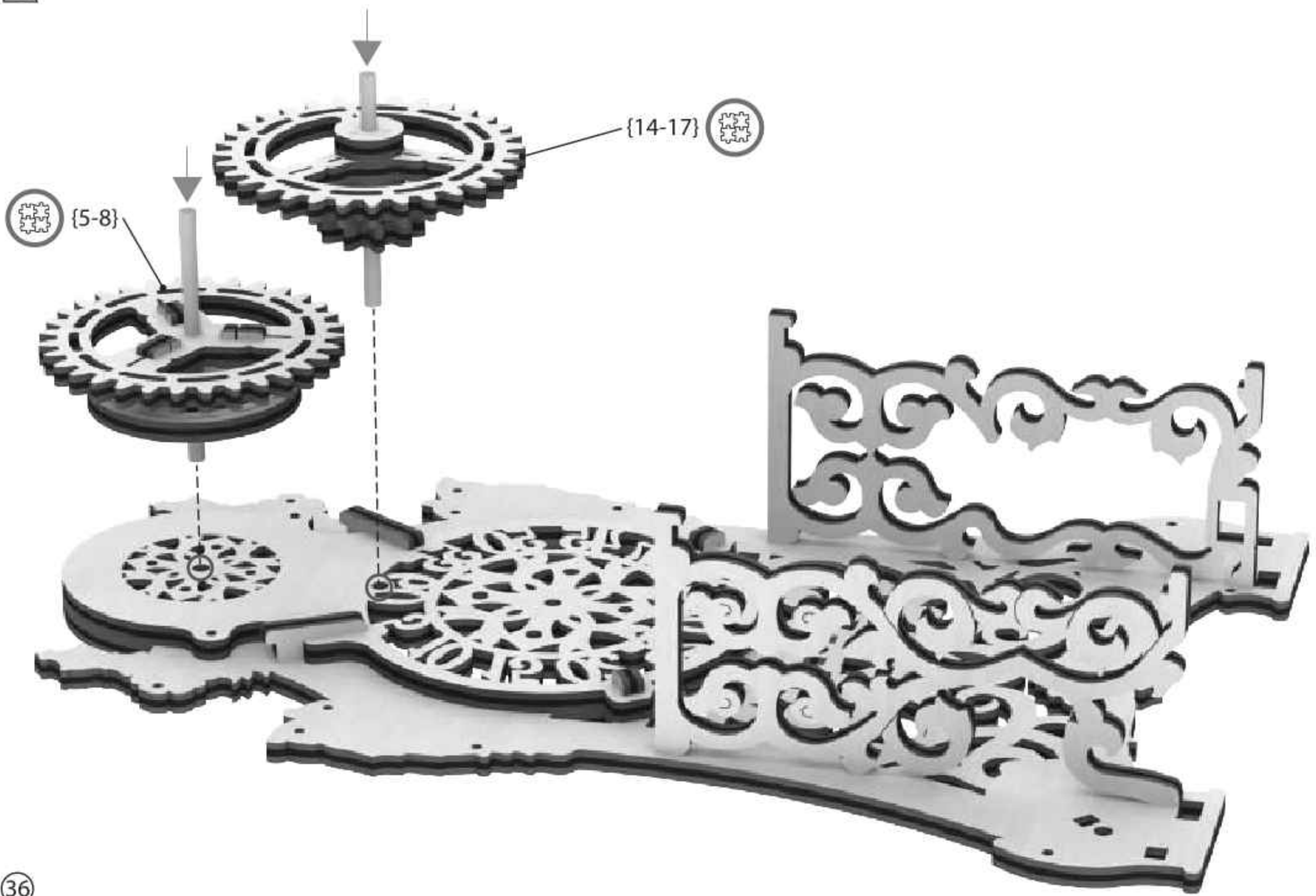

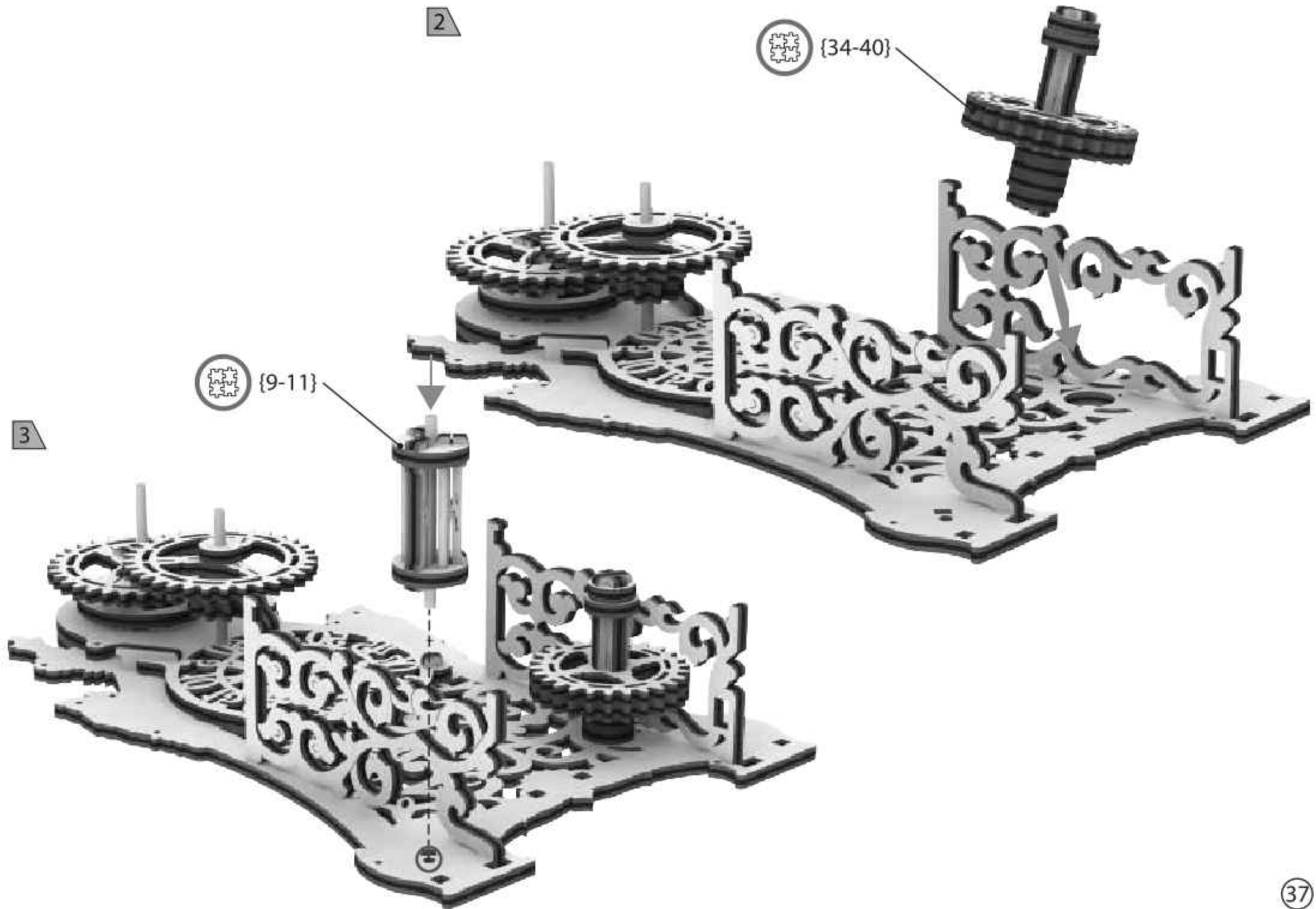

4

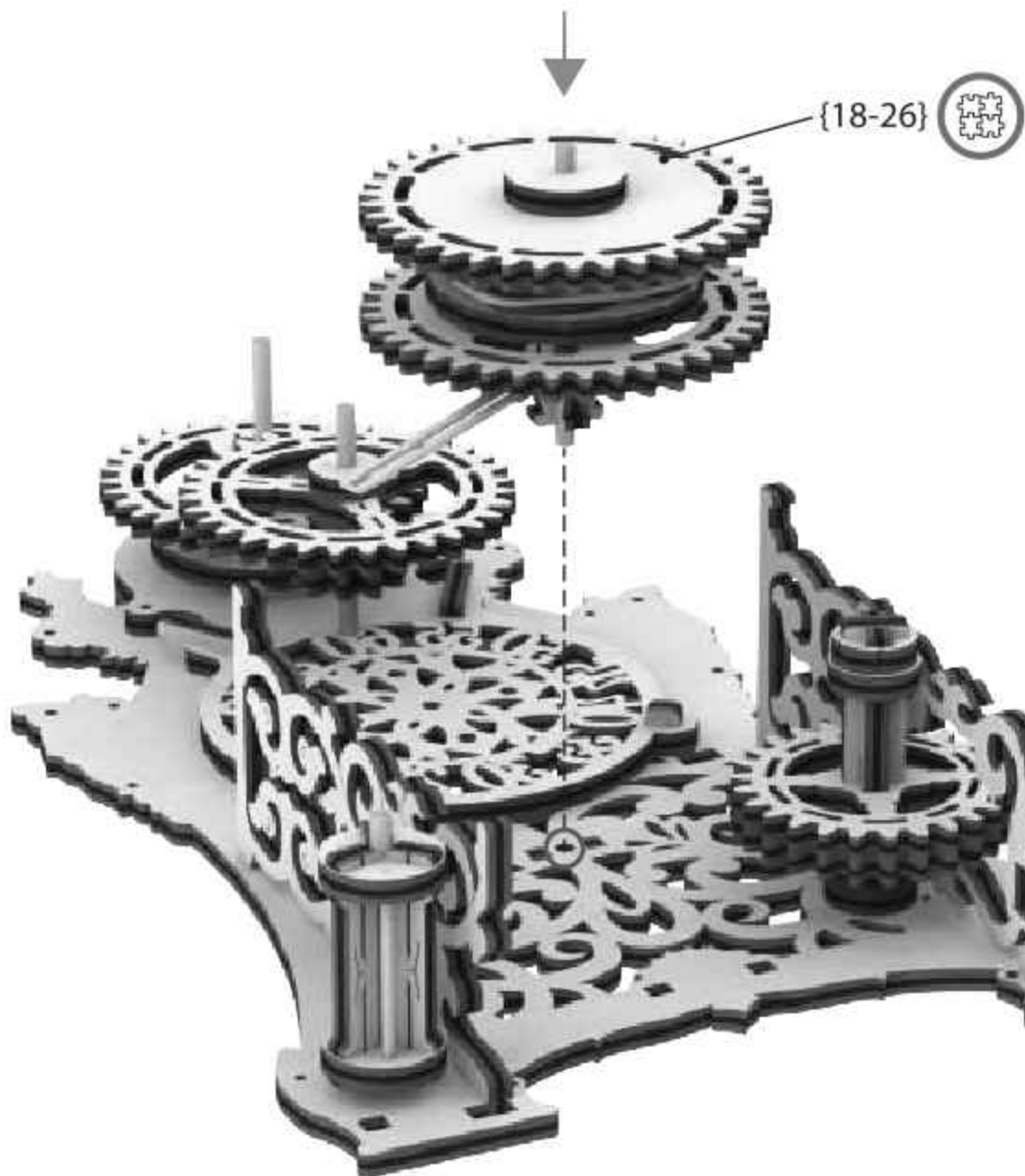

5



6

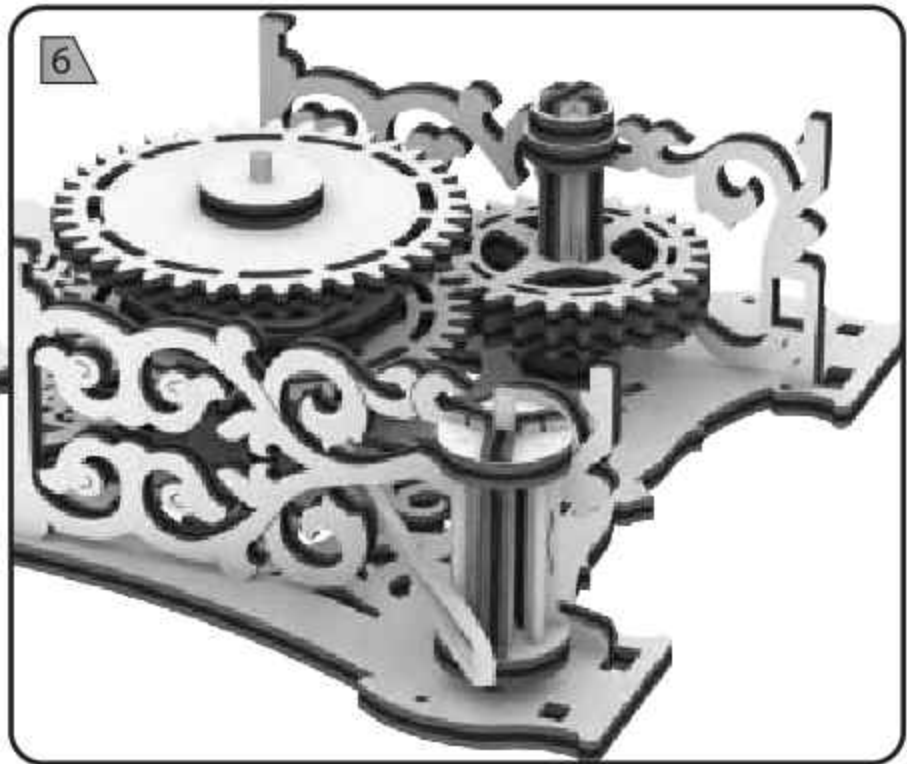



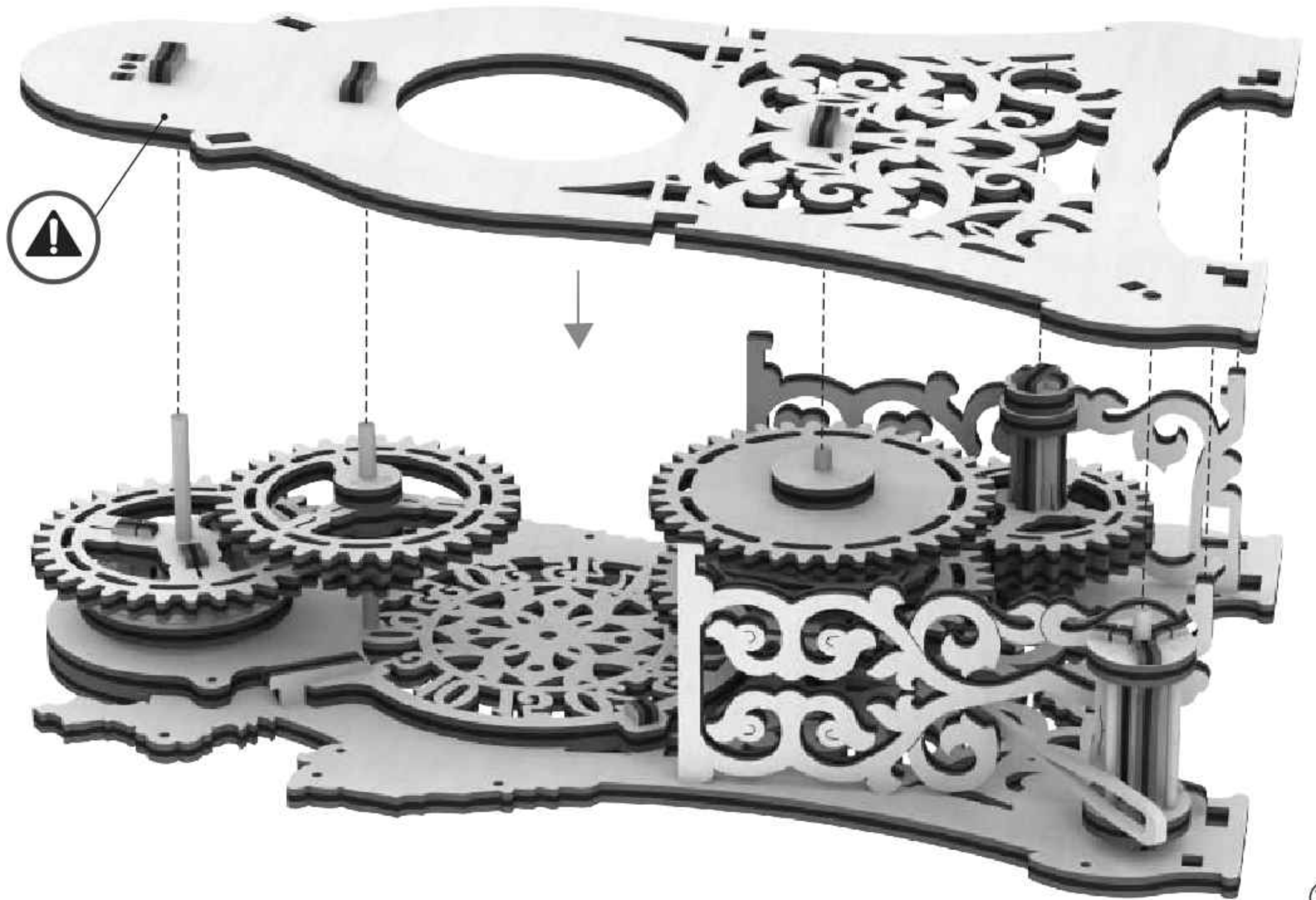

1

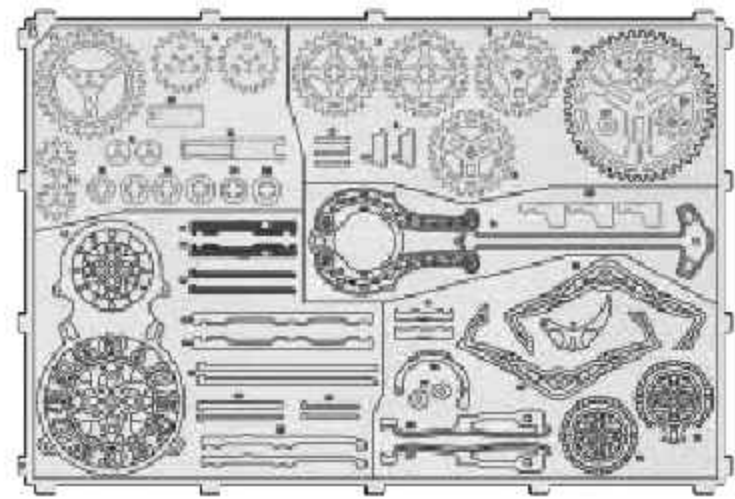
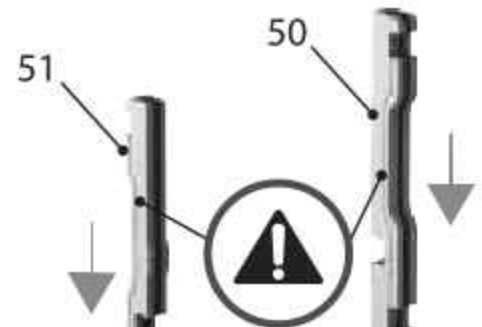

2



40

3

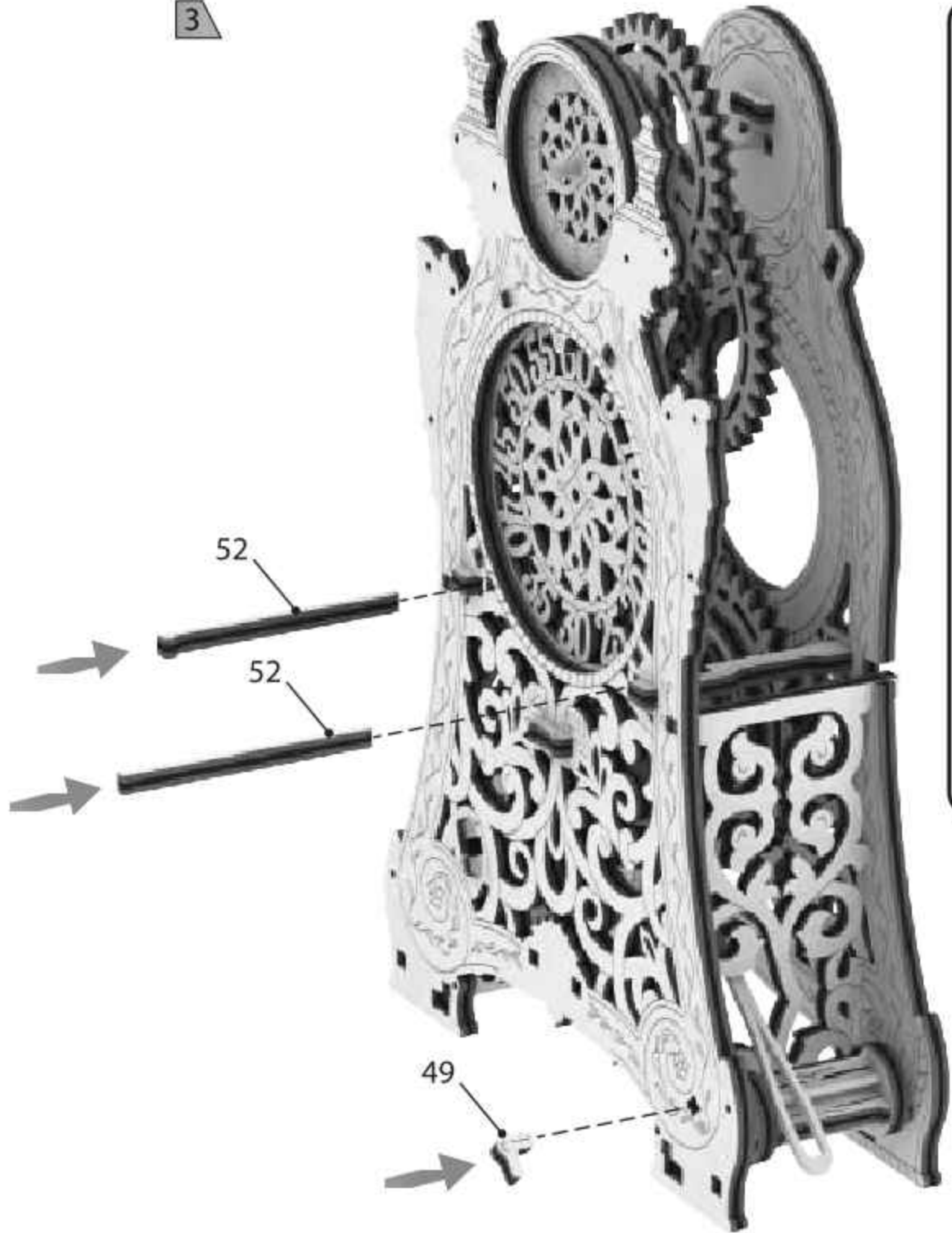

4

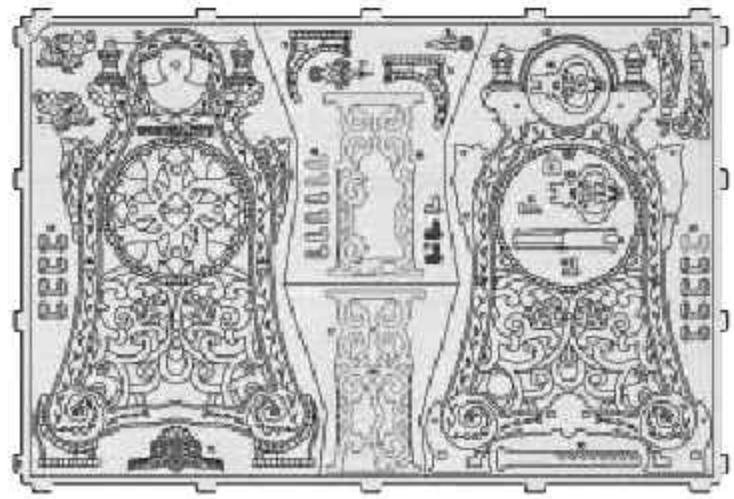
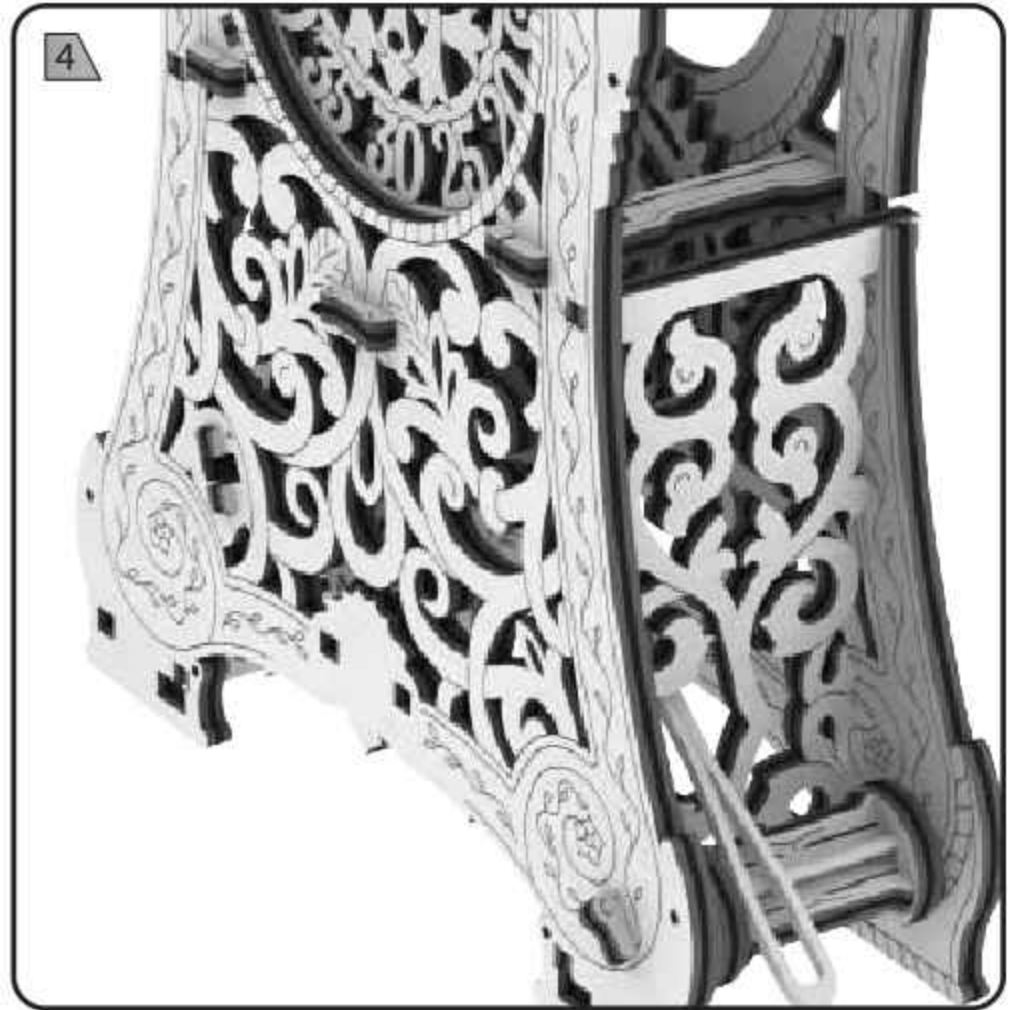

1

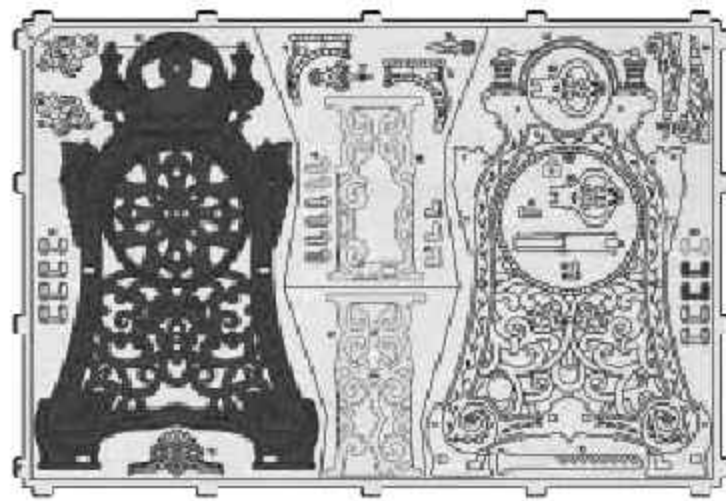
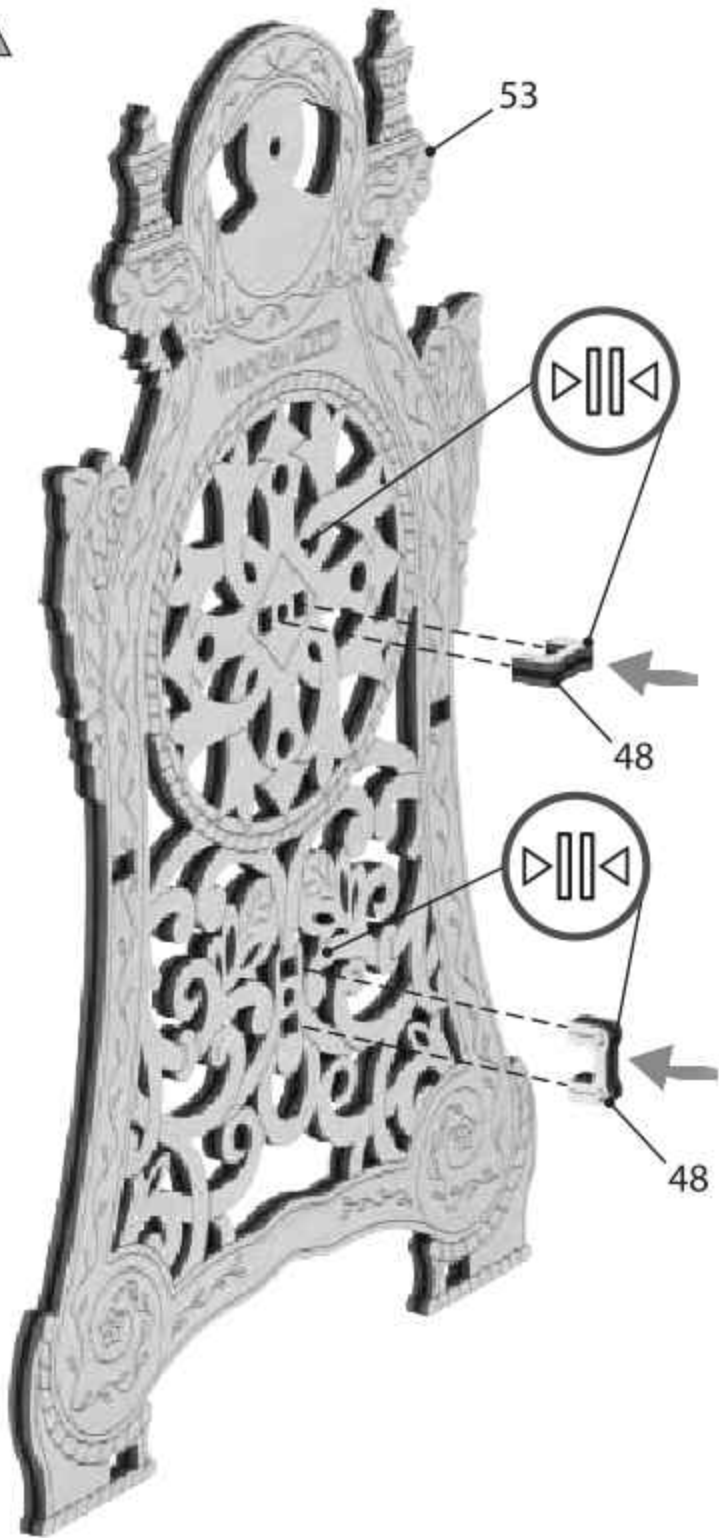

2





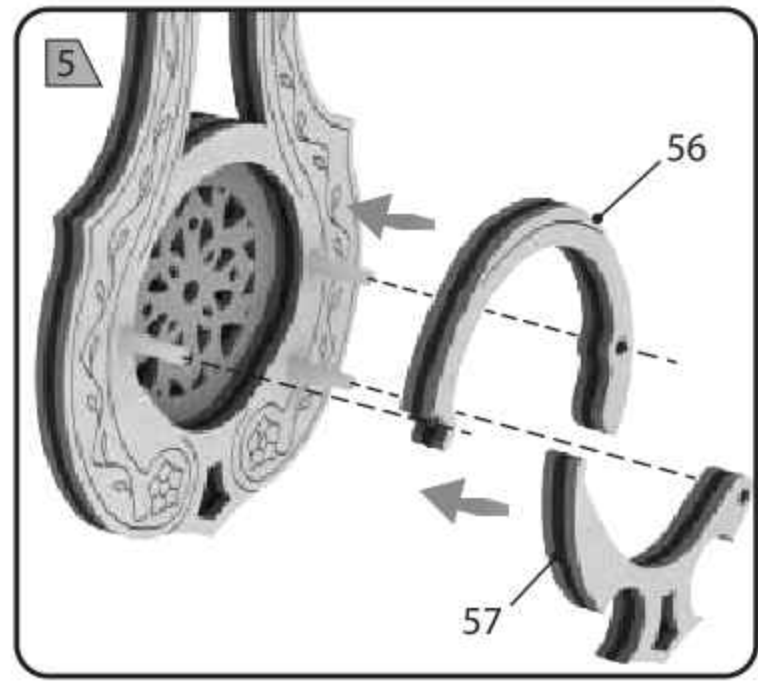
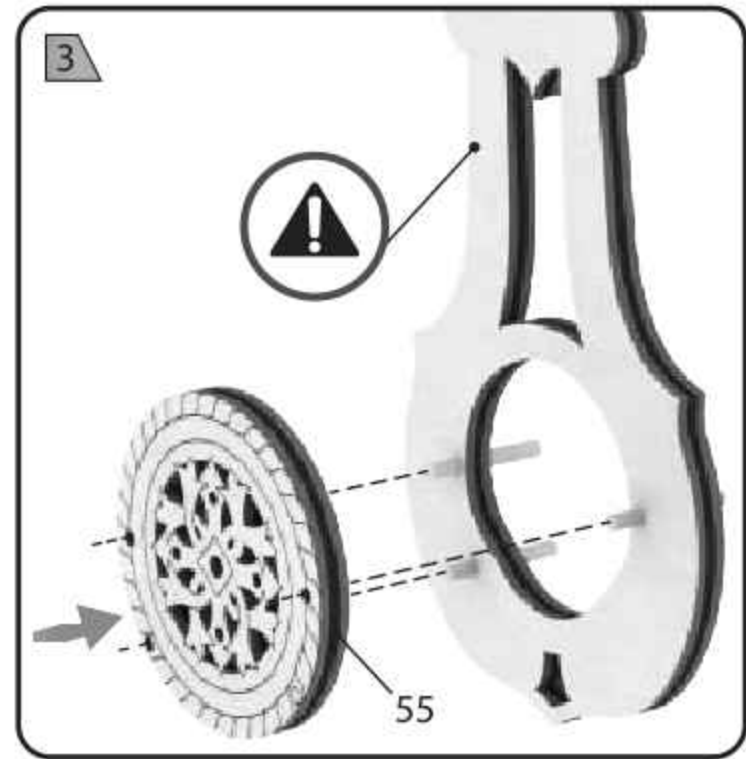
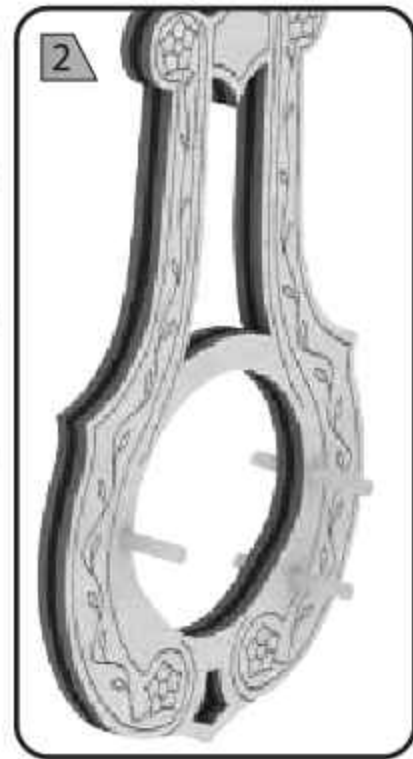
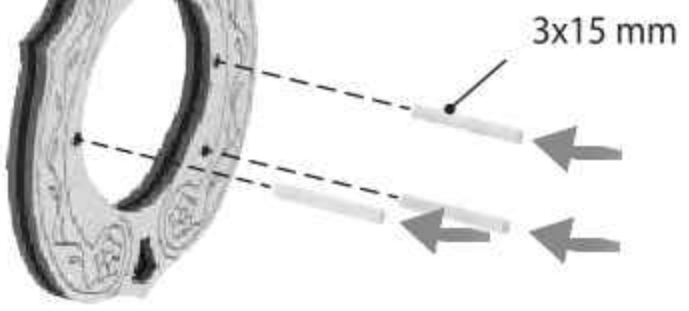
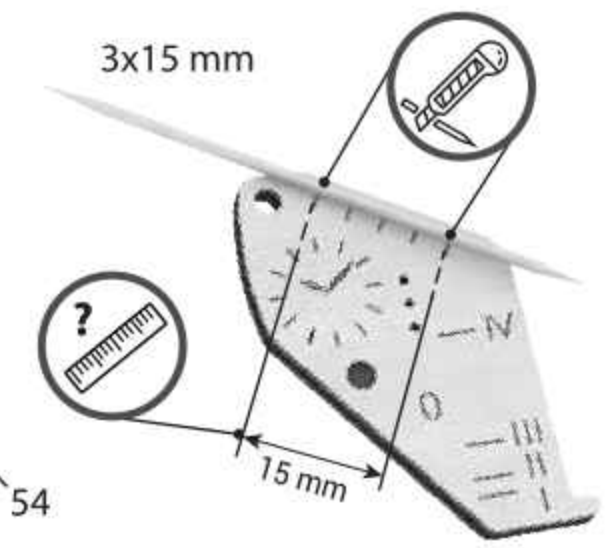
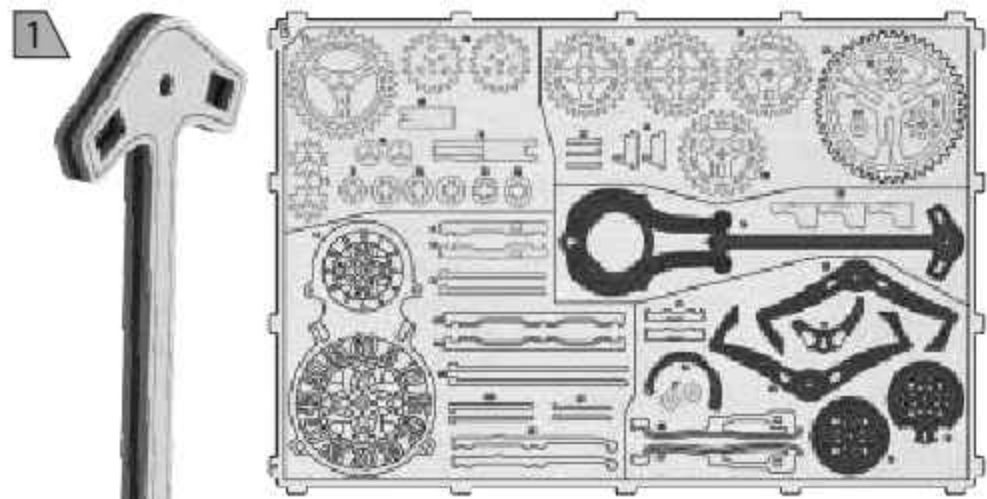



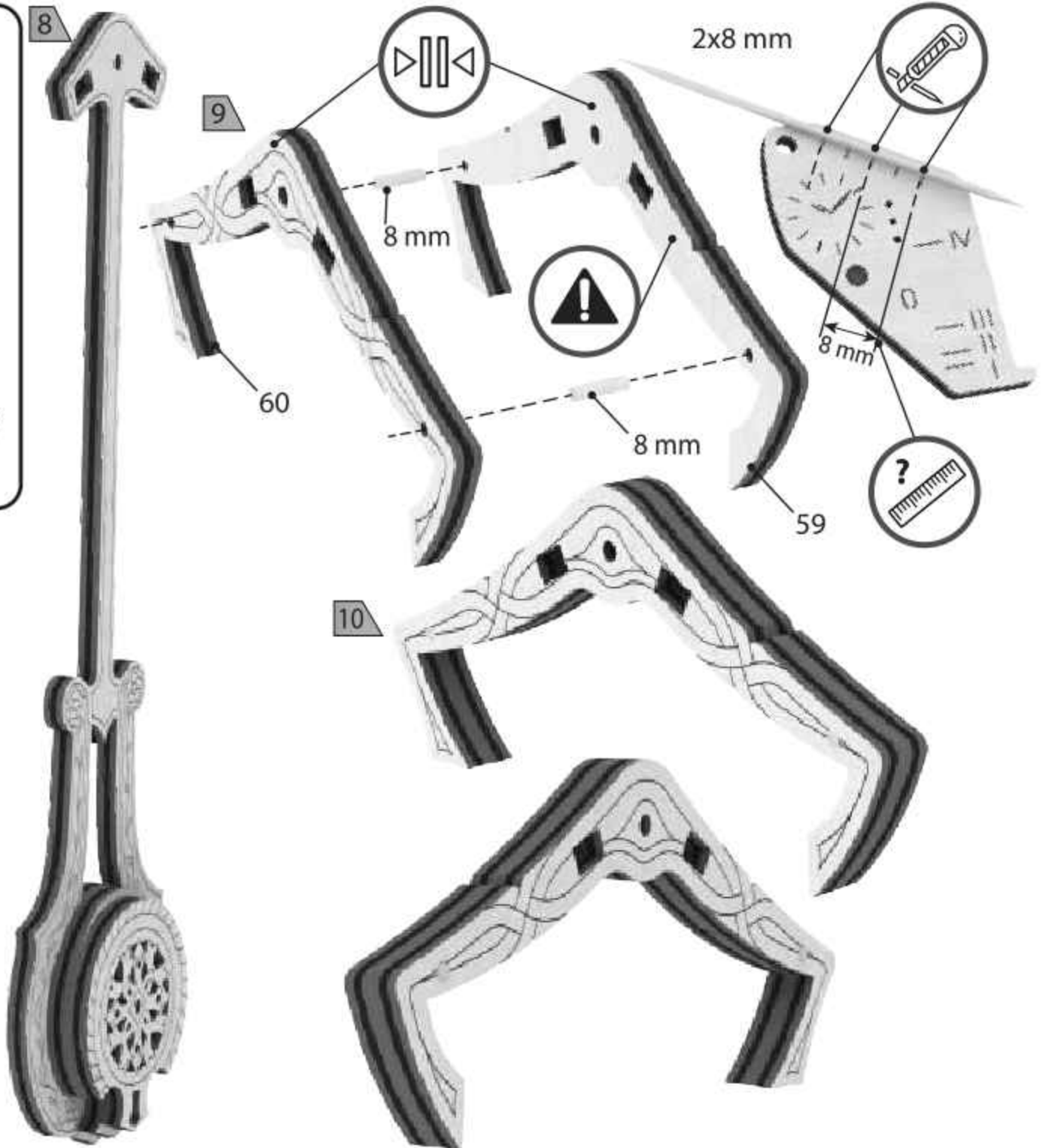
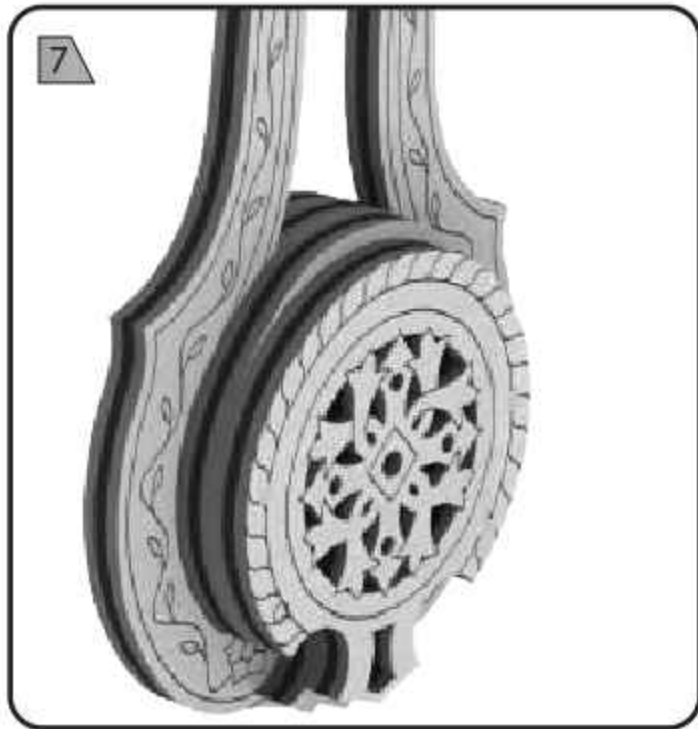
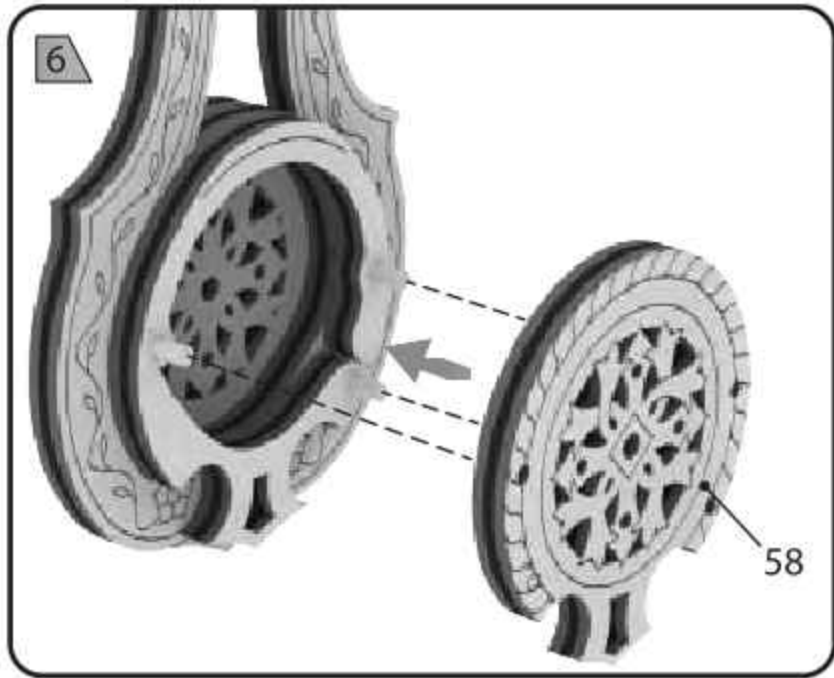

1

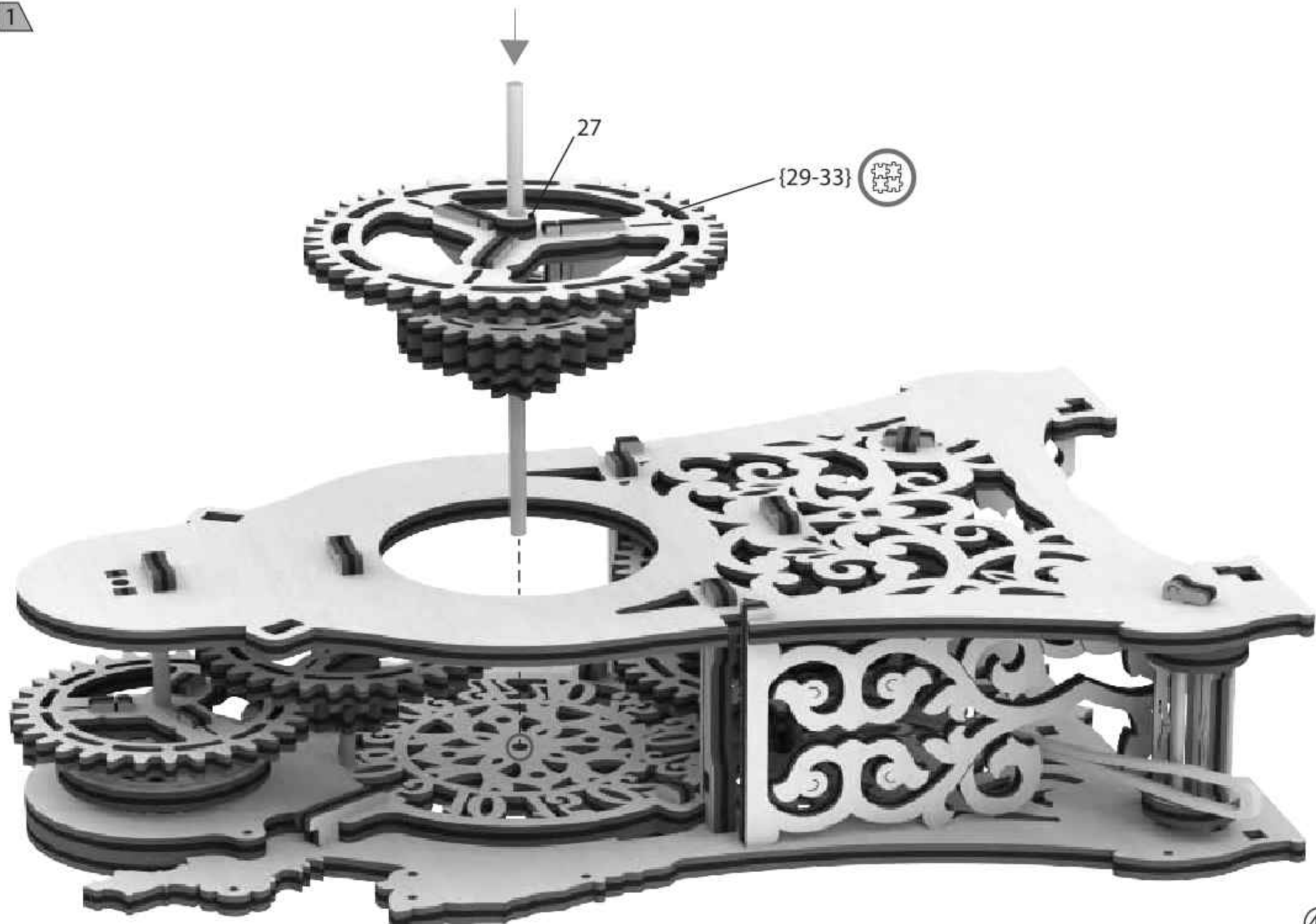

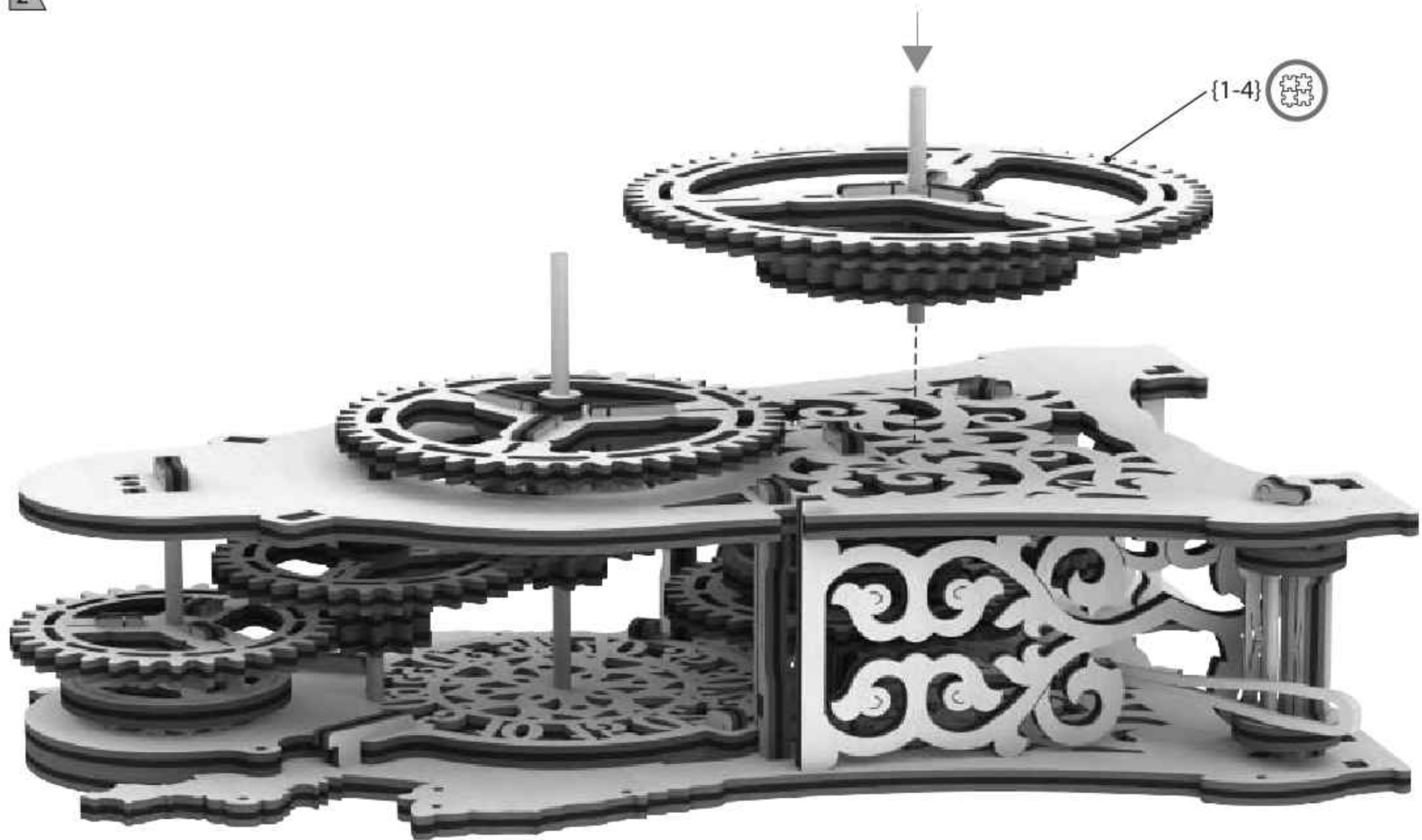

3

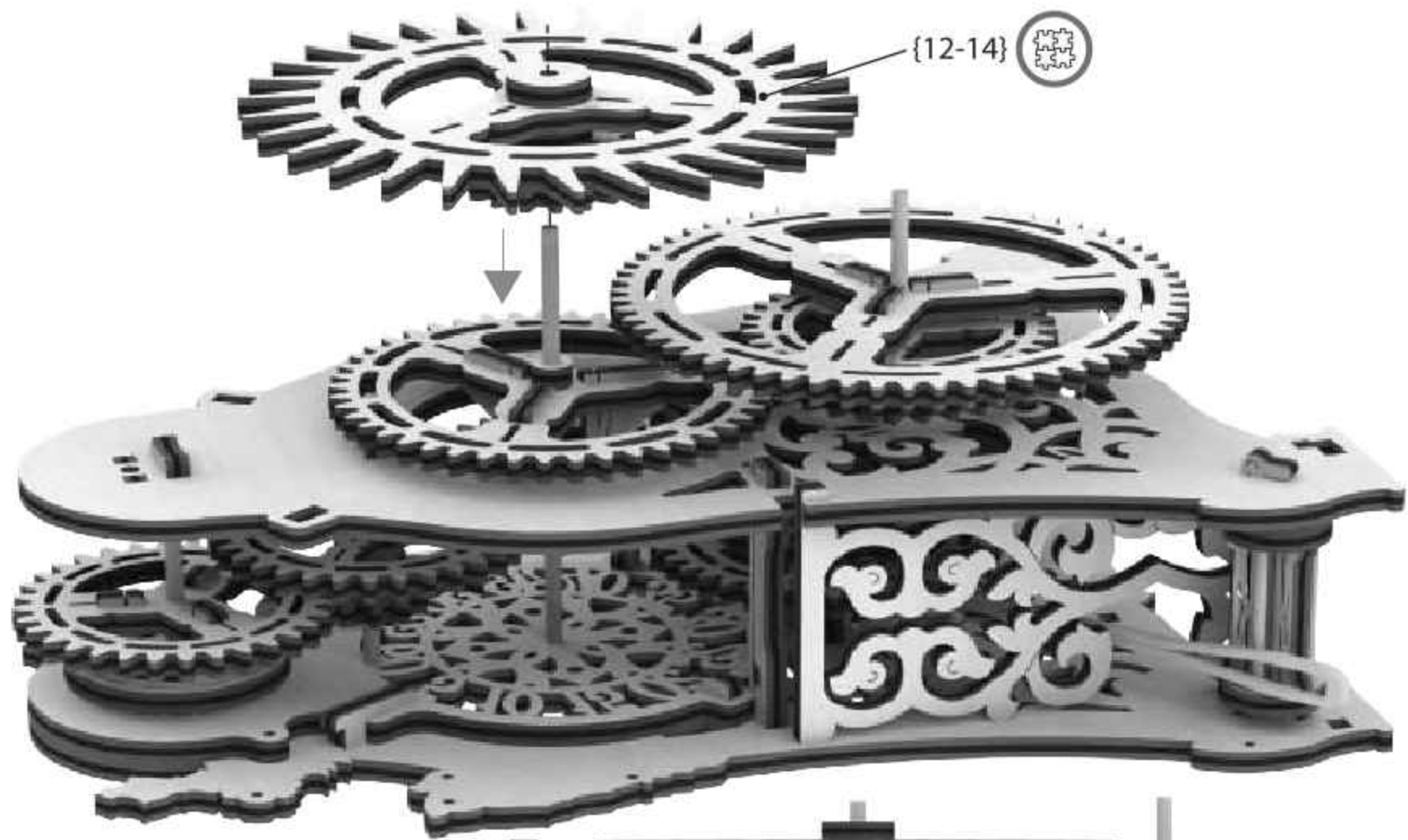

4

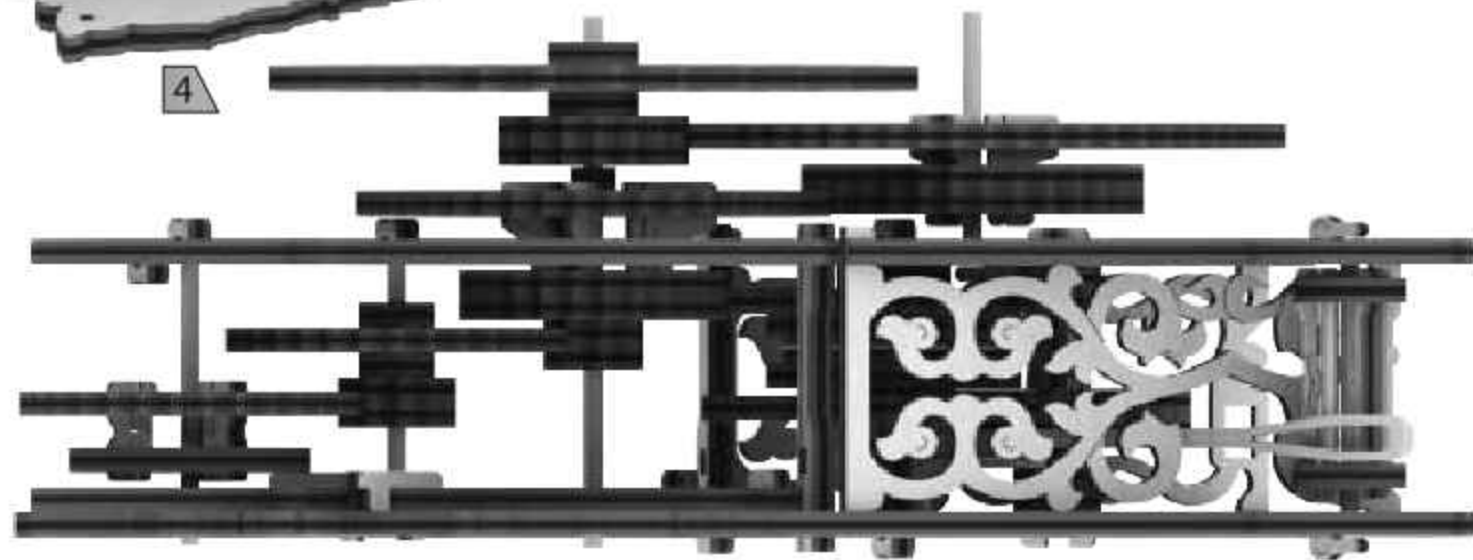

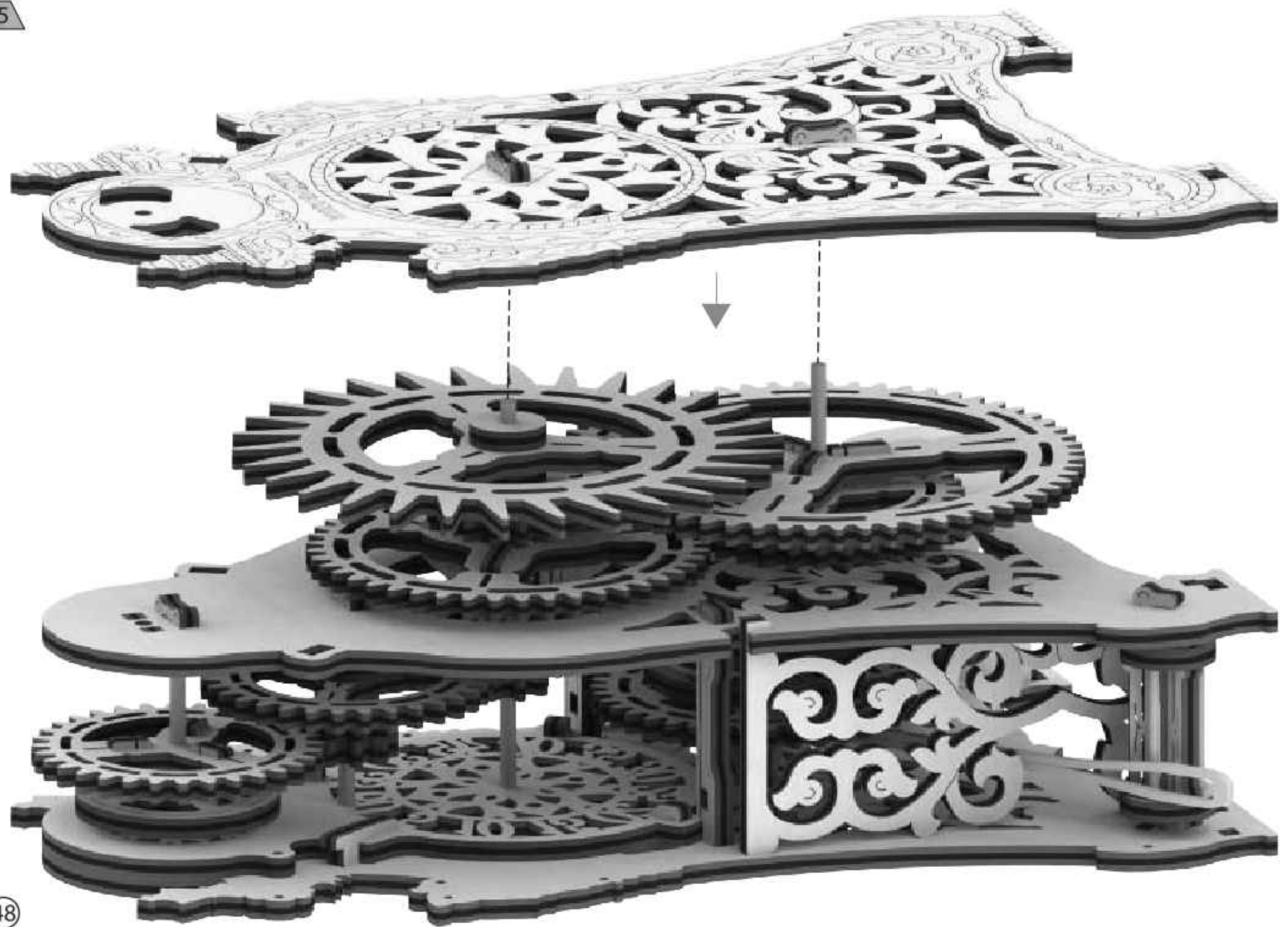



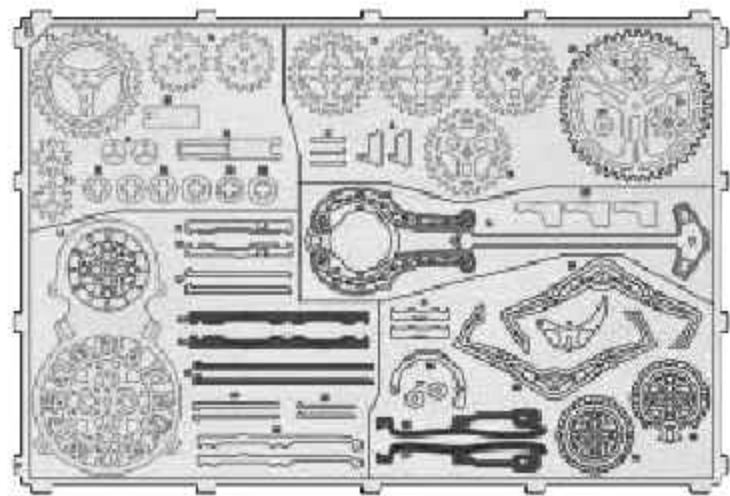

1

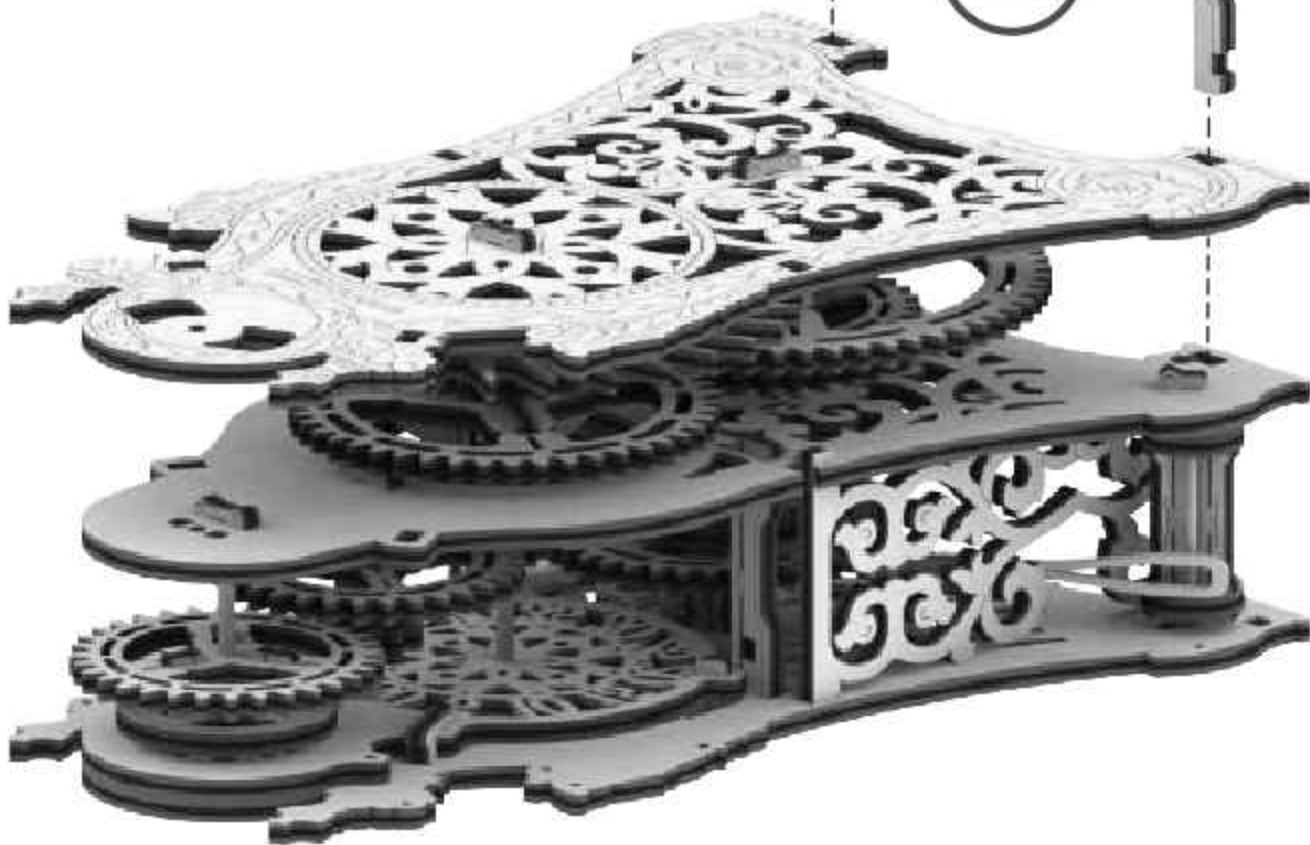
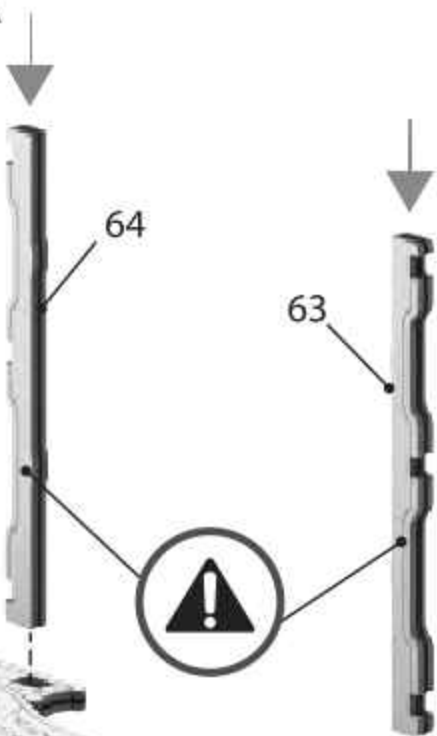

2

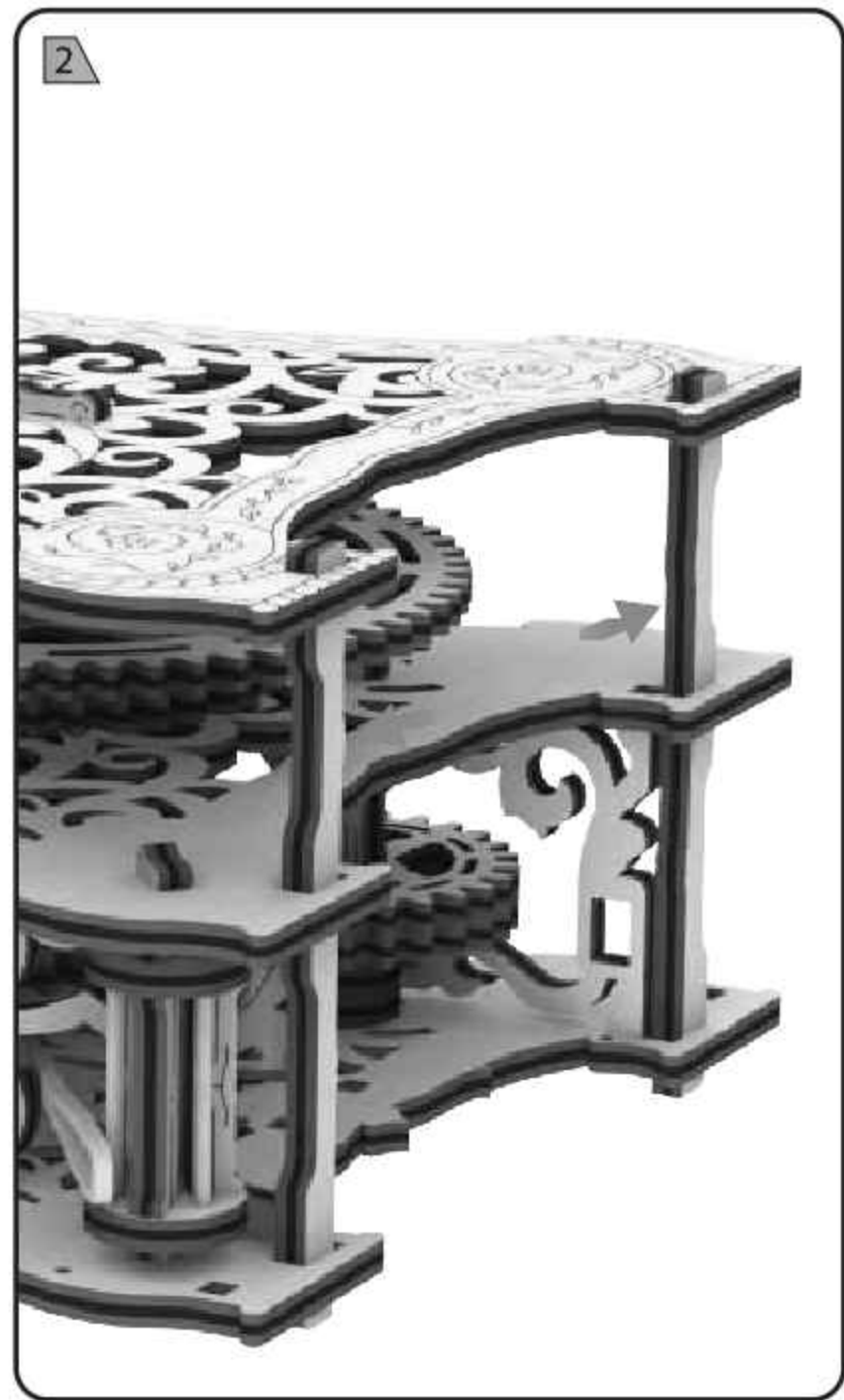

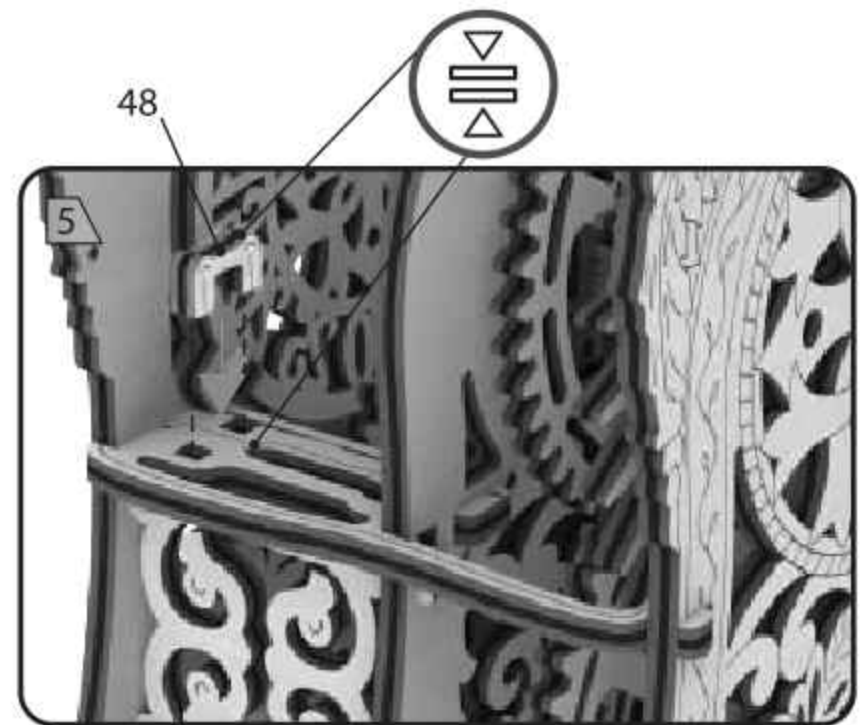
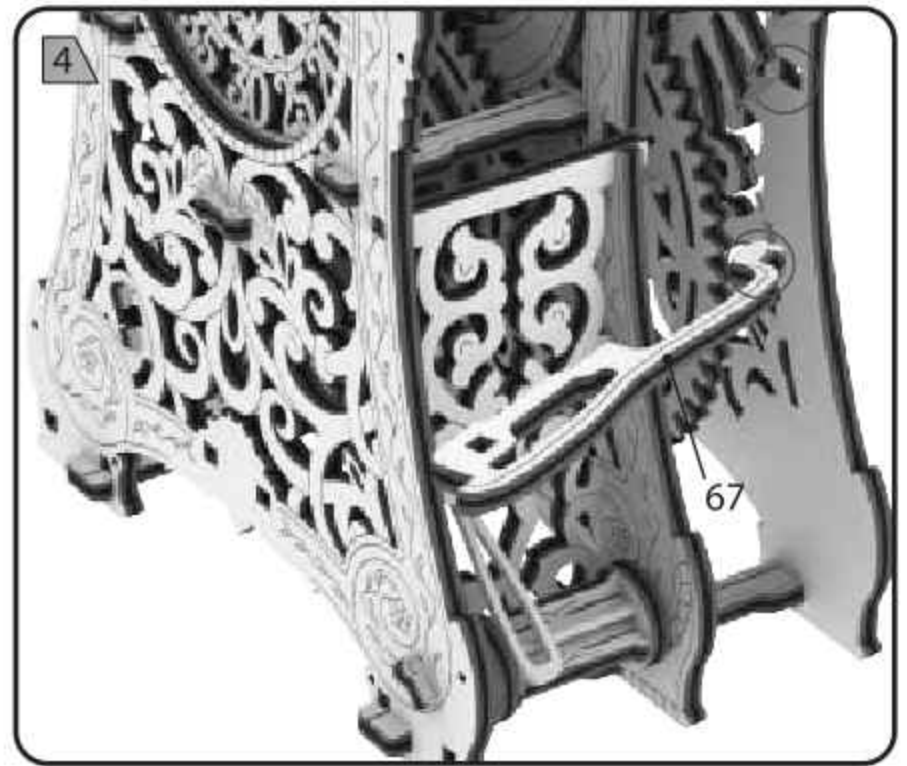
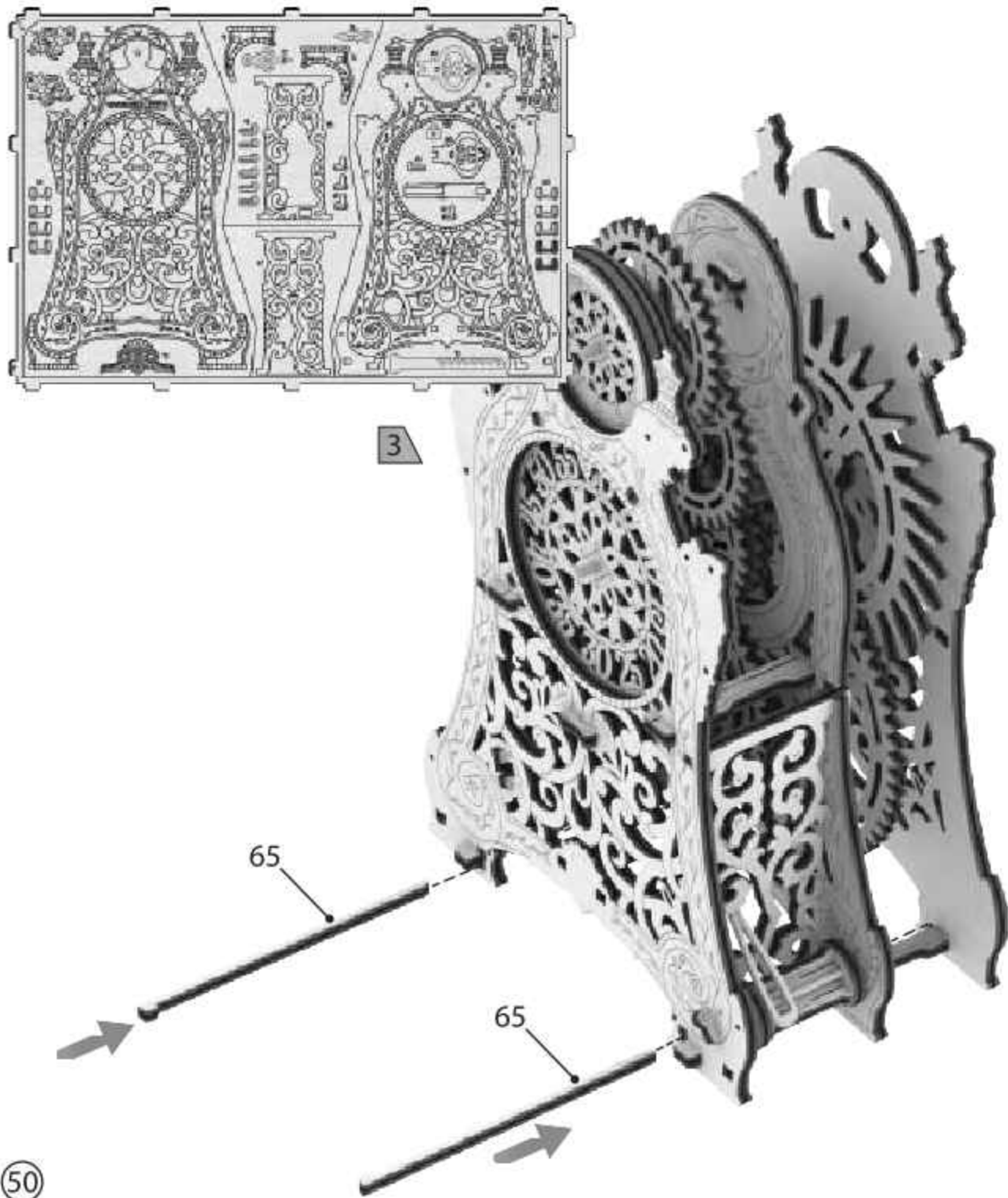

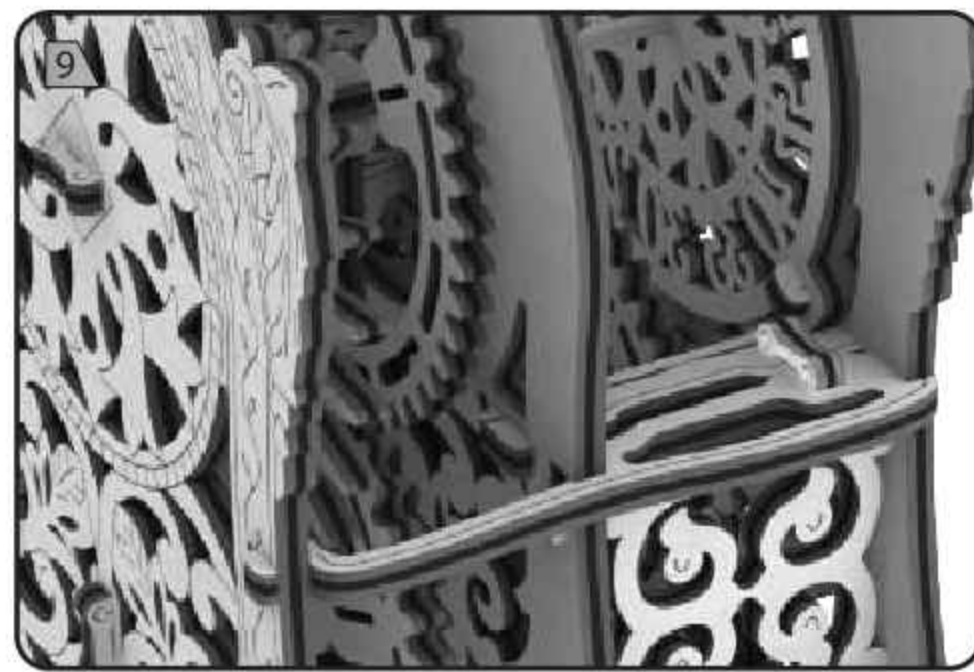
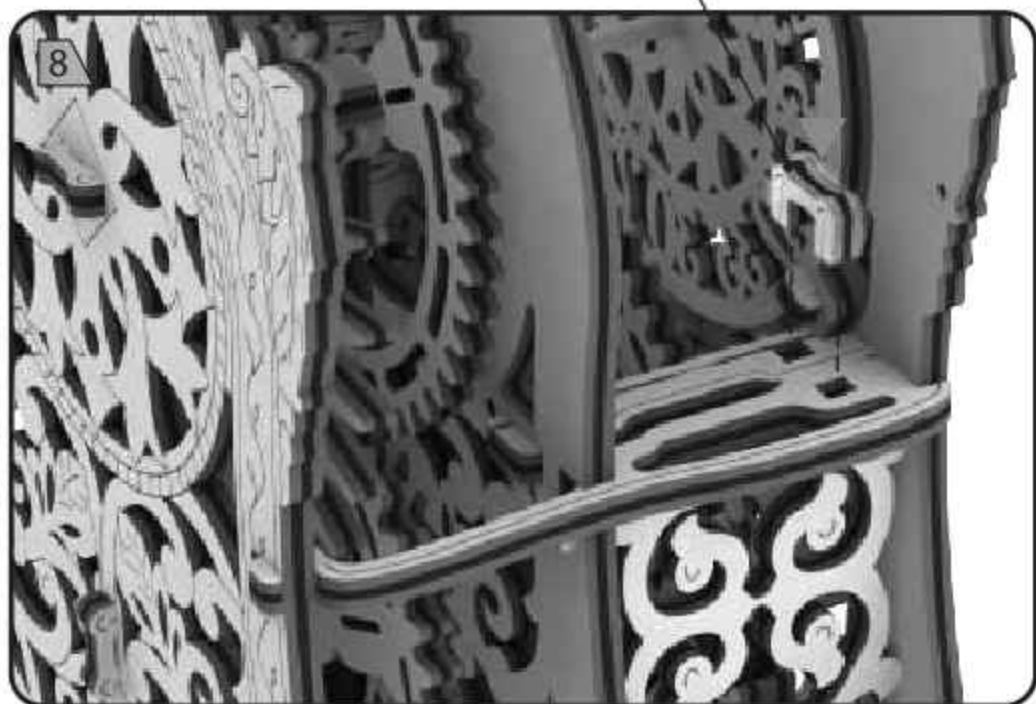
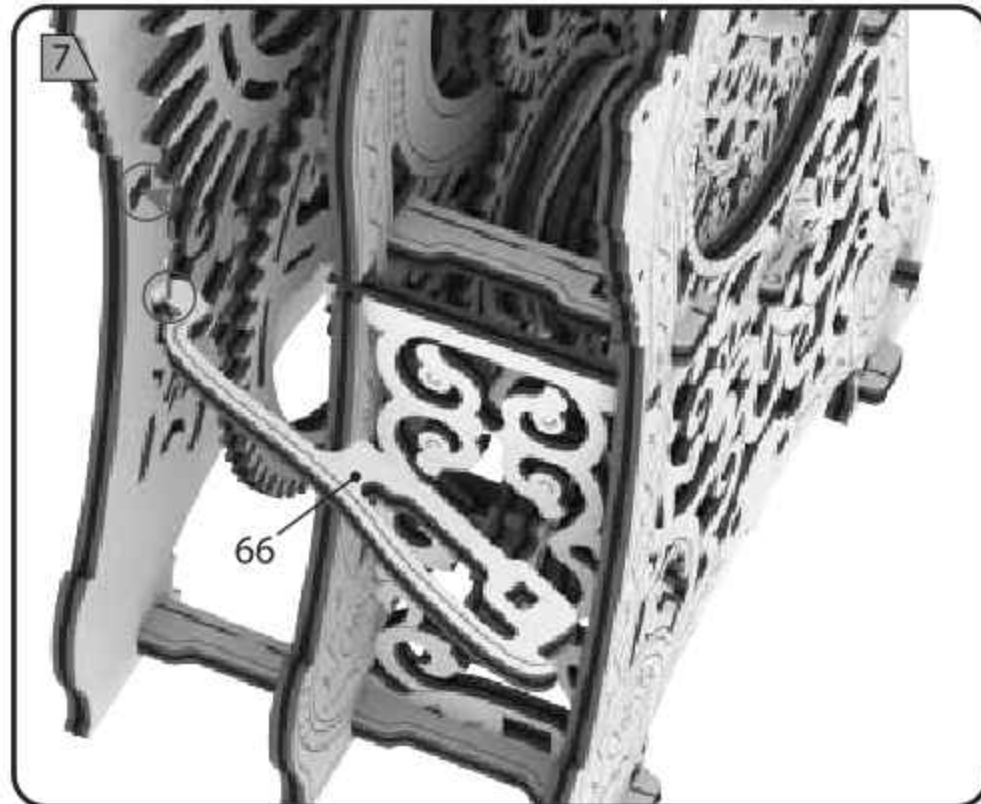

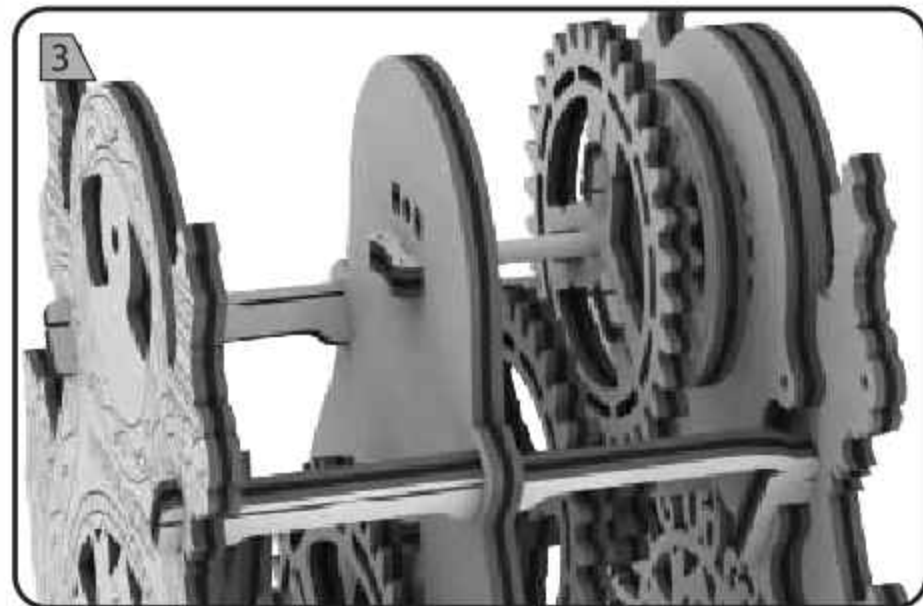
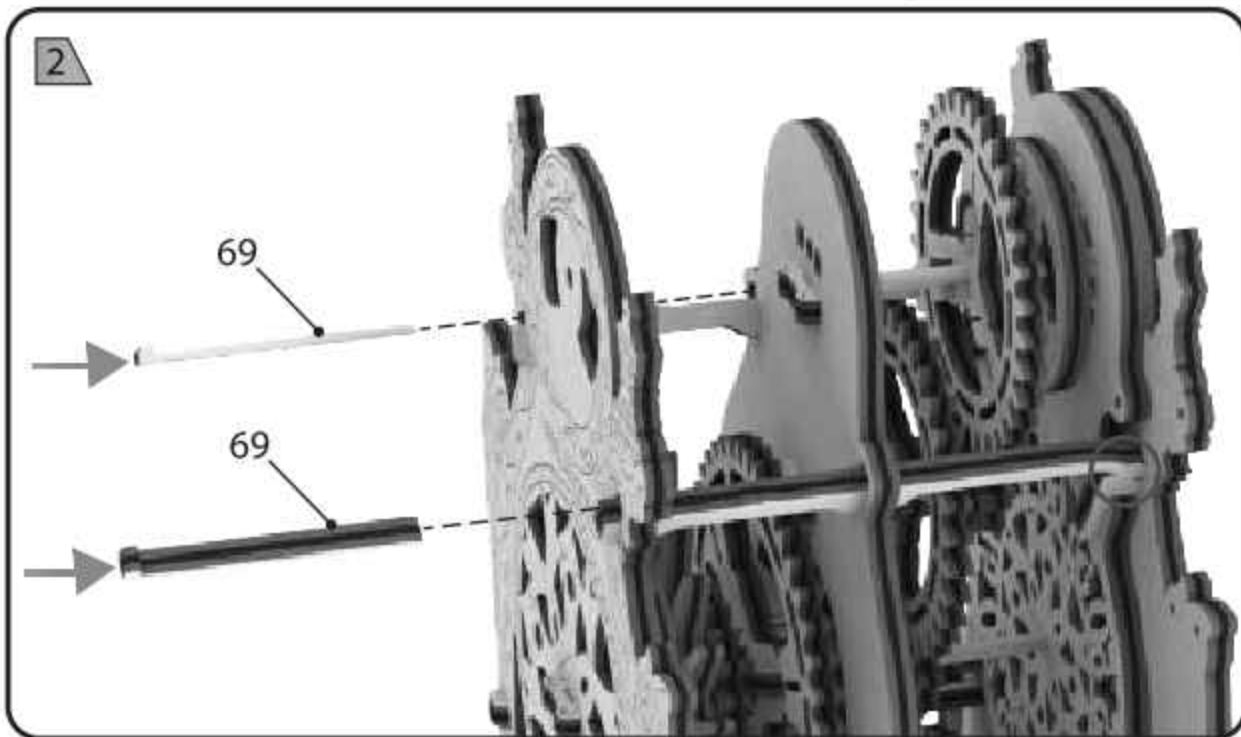
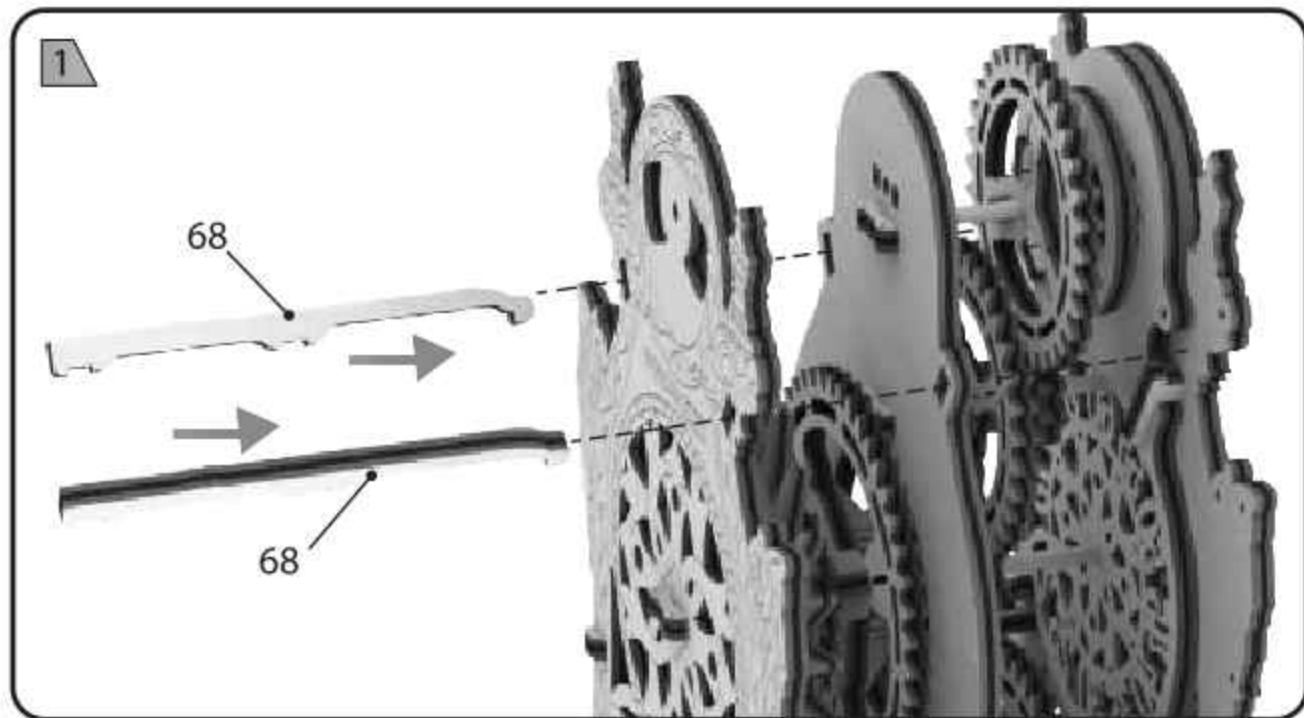
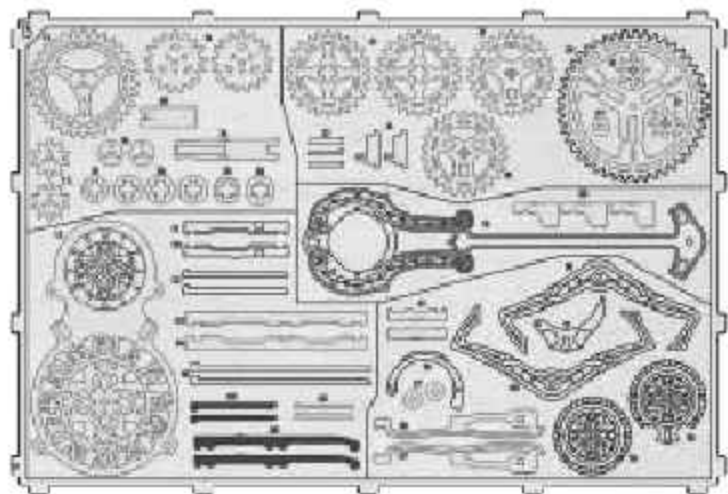



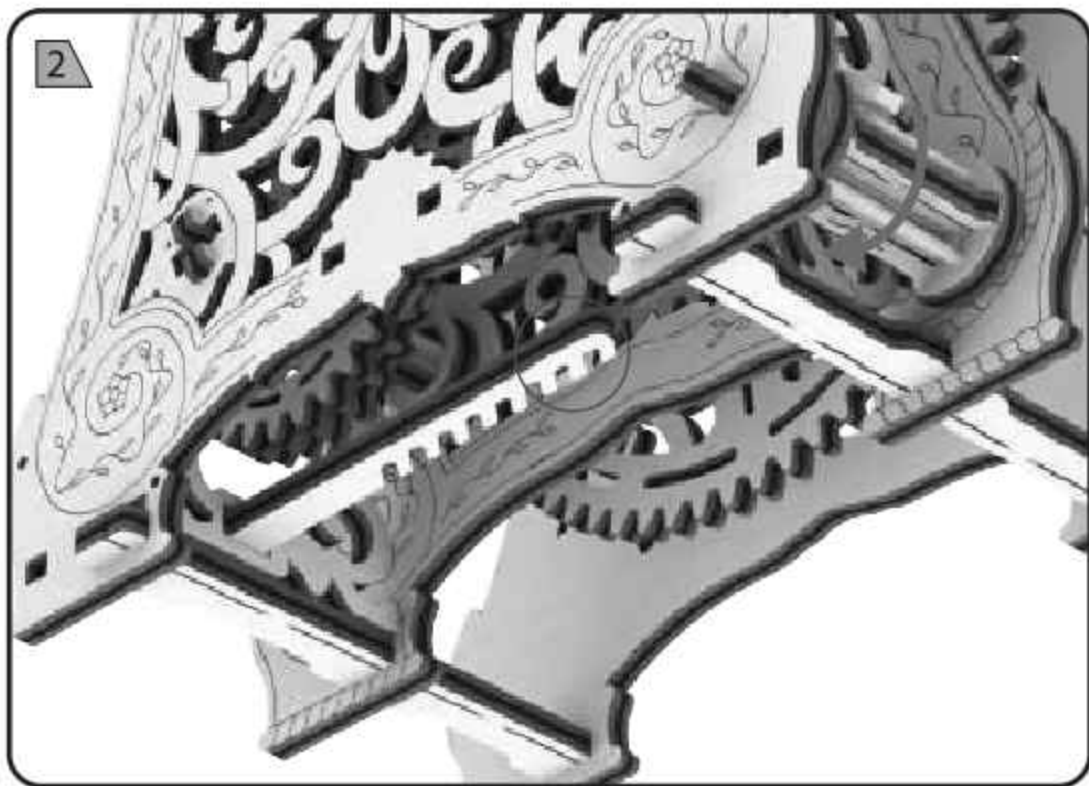
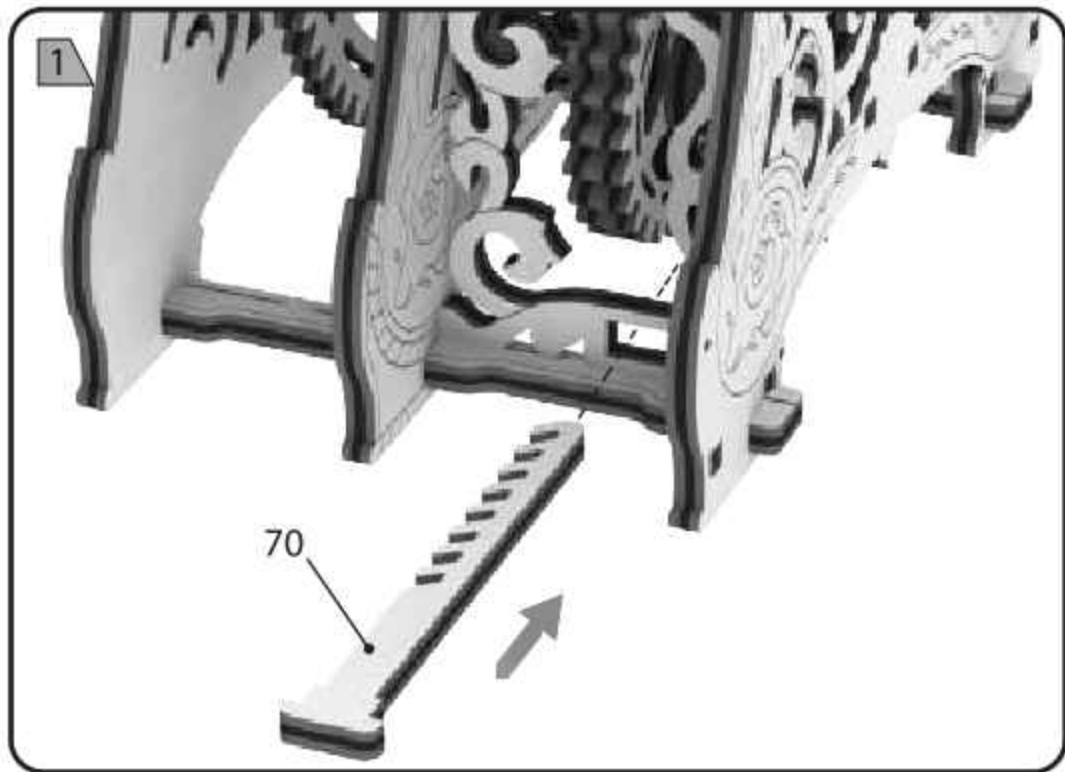
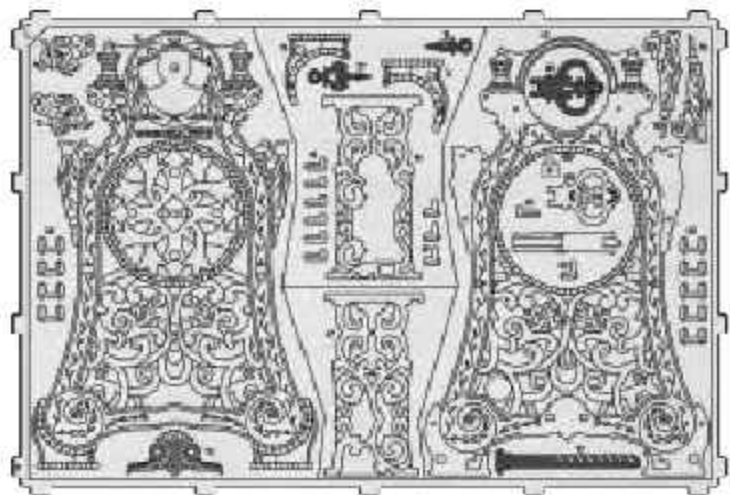



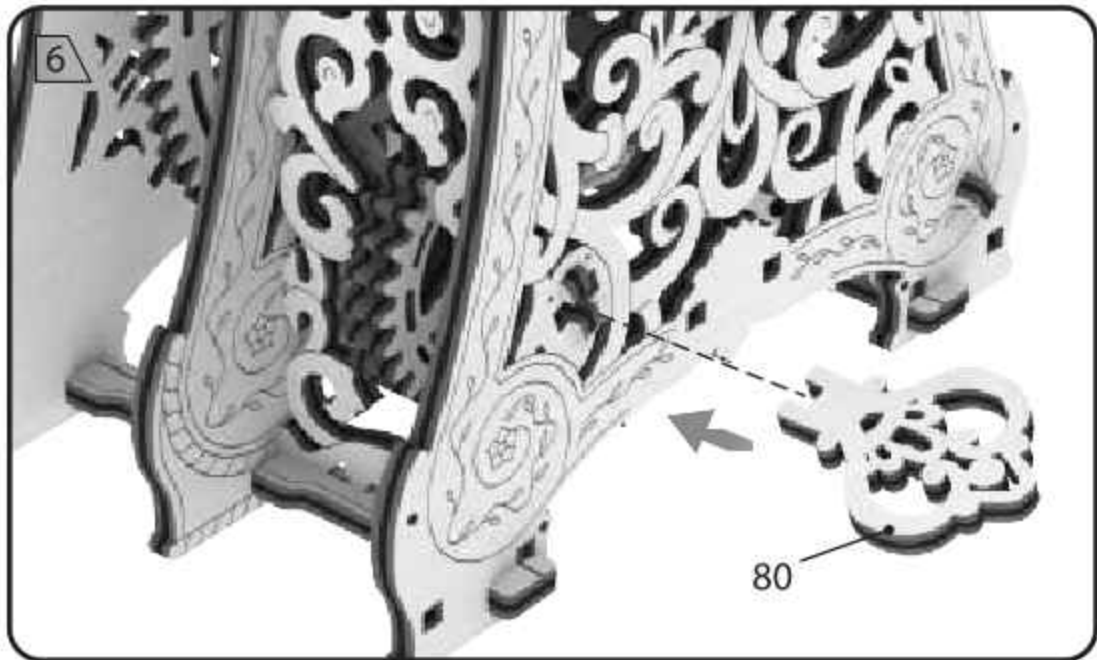
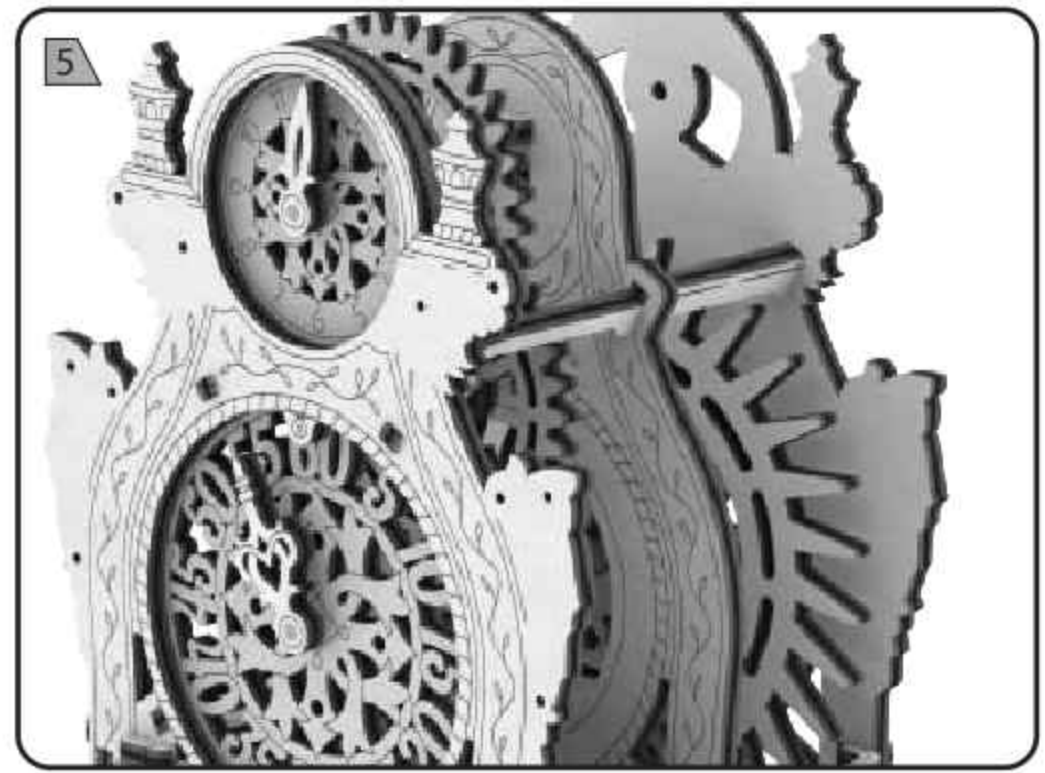
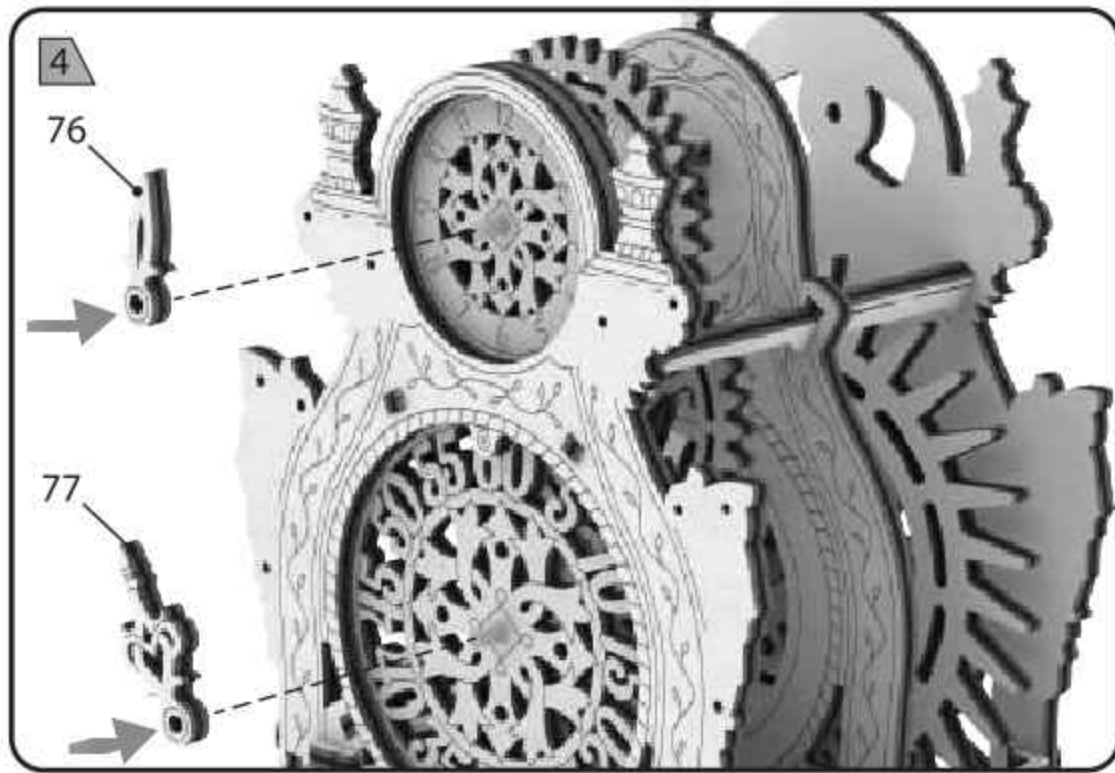



**EN** Before installing the pendulum, check operability of the clockwork mechanism. For this purpose, wind the clock up with the key and make sure that all gears are moving in a smooth and uniform manner. If during operations the mechanism gets clogged or blocked, check the surfaces of the gears, remove any flaws and grease all the teeth with candle.

**FR** Avant d'installer le pendule, vérifiez le fonctionnement du mécanisme d'horlogerie. Pour ce faire, remontez l'horloge avec la clé et assurez-vous que tous les engrenages se déplacent d'une manière lisse et uniforme. Si pendant les opérations le mécanisme est bouché ou bloqué, vérifiez la surface des engrenages, éliminez les défauts et graissez toutes les dents avec une bougie.

**ES** Antes de instalar el péndulo es necesario revisar el funcionamiento del mecanismo de reloj. Para esto es necesario darle cuerda con la llave y asegurarse de que todos los engranajes se mueven de manera regular. Si durante el funcionamiento el mecanismo se atasca, revise la superficie de piñones – no debe haber rebaba y todos los dientes deben estar encerados con una vela.

**PL** Przed założeniem wahadła sprawdź czy pracuje mechanizm zegarowy. W tym celu nastaw zegar za pomocą klucza i przekonaj się, że wszelkie koła zębate kręcą się równomiernie. Jeżeli podczas pracy mechanizm się zacina, sprawdź powierzchnię kół zębatych aby na niej nie było zadziorów i wszelkie ząbki były posmarowane świecą.

**DE** Die Funktion des Uhrwerks muss vor dem Einbau des Pendels überprüft werden. Wickeln Sie die Uhr zu diesem Zweck mit dem Schlüssel auf und stellen Sie sicher, dass sich alle Zahnräder gleichmäßig und leichtgängig bewegen. Wenn der Mechanismus während des Betriebs blockiert, dann überprüfen Sie bitte die Oberflächen der Zahnräder. Entfernen Sie eventuelle Grate und fetten Sie alle Zähne mit Kerzenwachs ein.

**RU** Перед установкой маятника следует проверить работоспособность часового механизма. Для этого нужно завести часы ключом, и убедиться, что все шестерни крутятся равномерно. Если во время работы механизм заклинивает, проверьте поверхность шестерен, чтобы на ней не было заусенцев и все зубья были смазаны свечкой.

**IT** Prima di installare il pendolo si dovrebbe verificare la funzionalità del meccanismo dell'orologio. Per fare questo, è necessario caricare l'orologio con la chiave, e assicurarsi che tutti gli ingranaggi girano senza intoppi. Se durante il funzionamento il meccanismo si inceppa, controllare la superficie degli ingranaggi per far sì che su di essa non cerano le sbavature e tutti i denti sono stati lubrificati con una candela.

**CN** 在安装钟摆之前，先确保钟表装置机构的可运行性。可以通过扭转钥匙，确认所有齿轮平稳转动且一致。如果运行过程中出现阻塞或者卡死，请检查齿轮表面，去除毛刺并用蜡加以润滑。

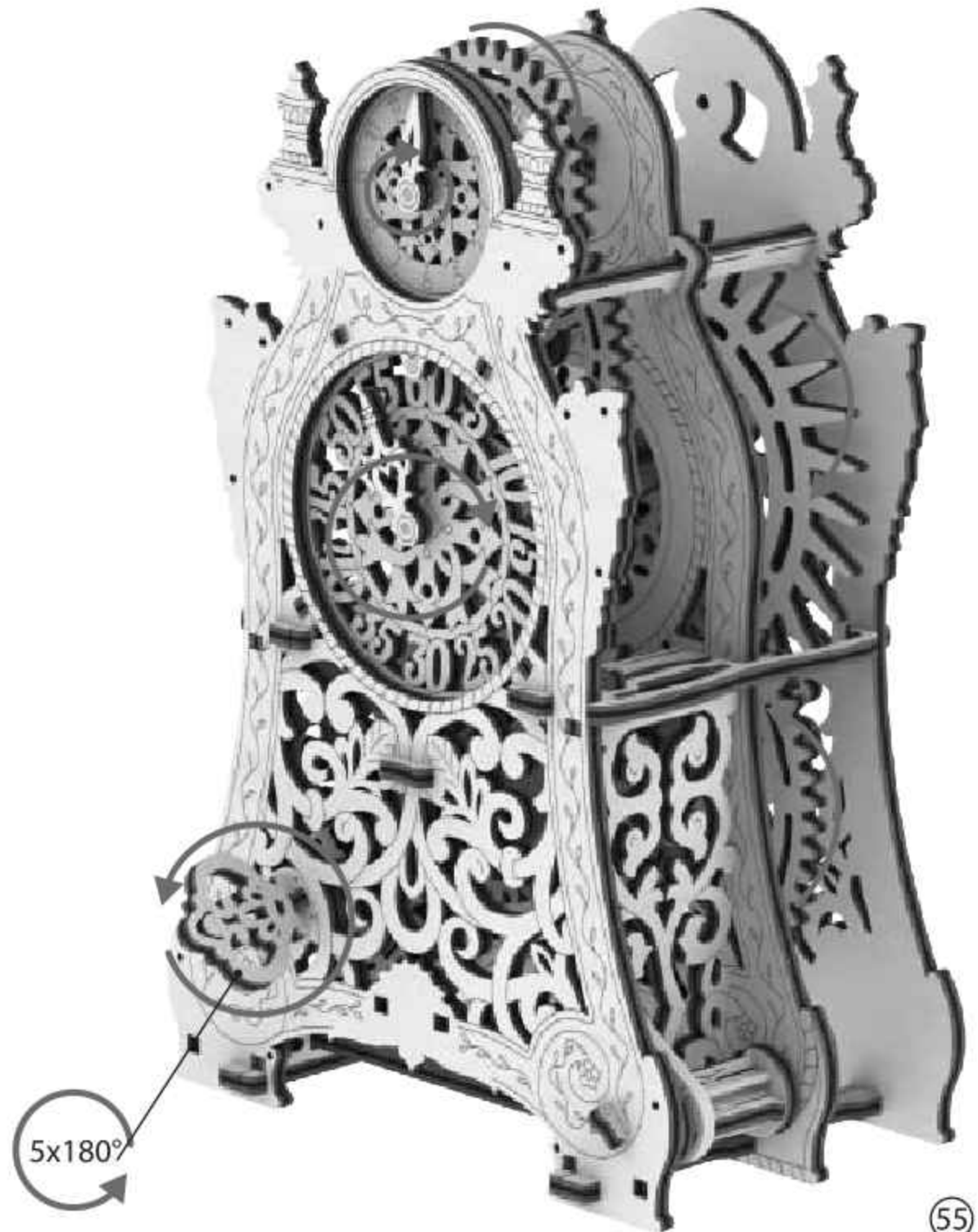

1

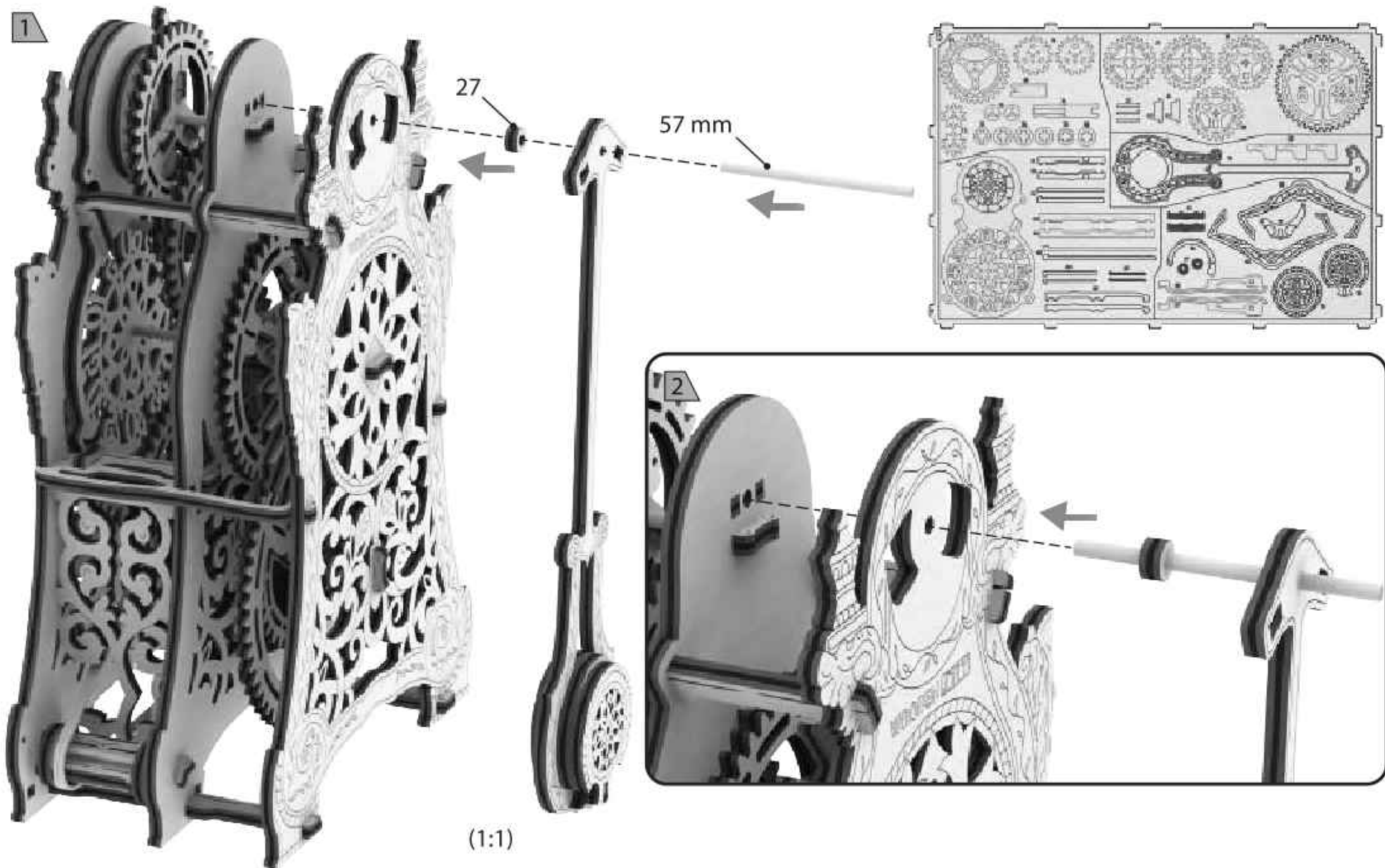

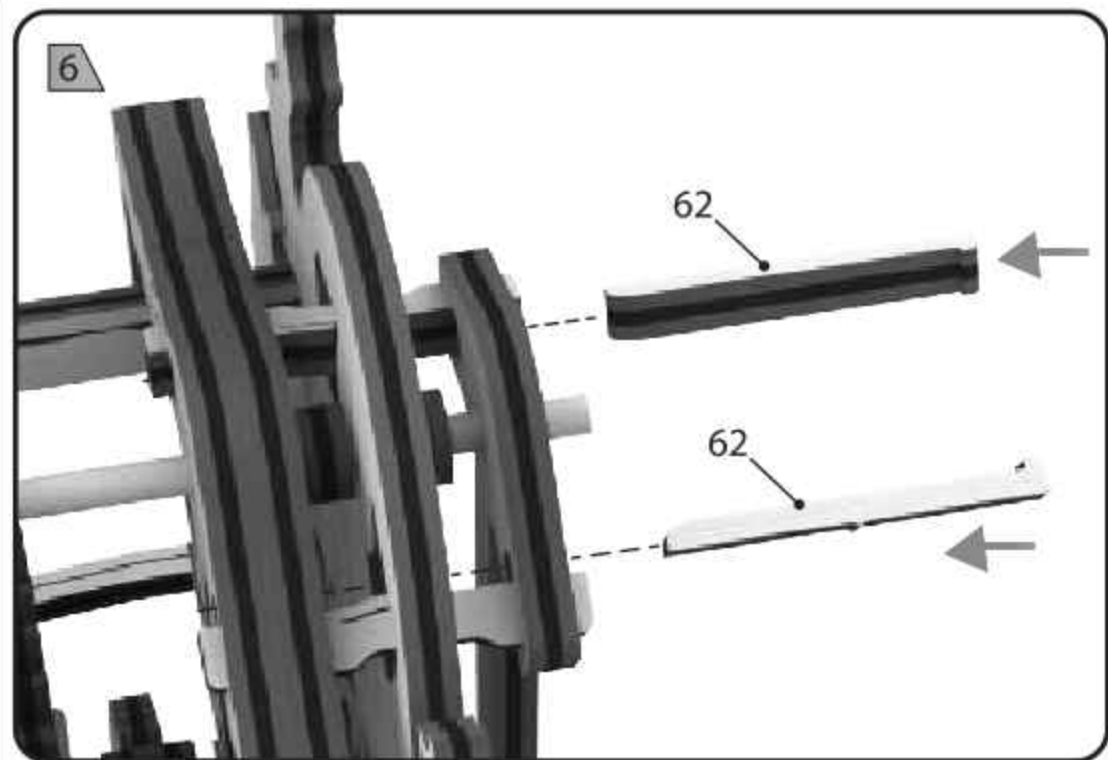
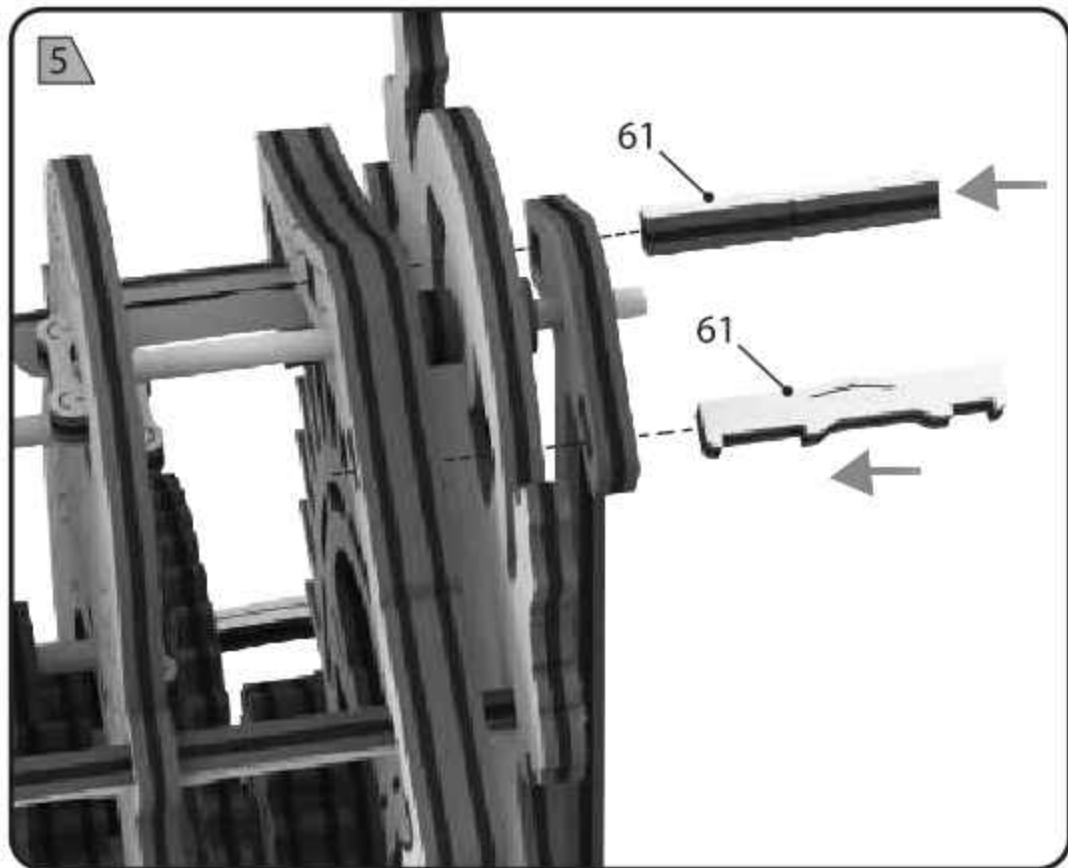
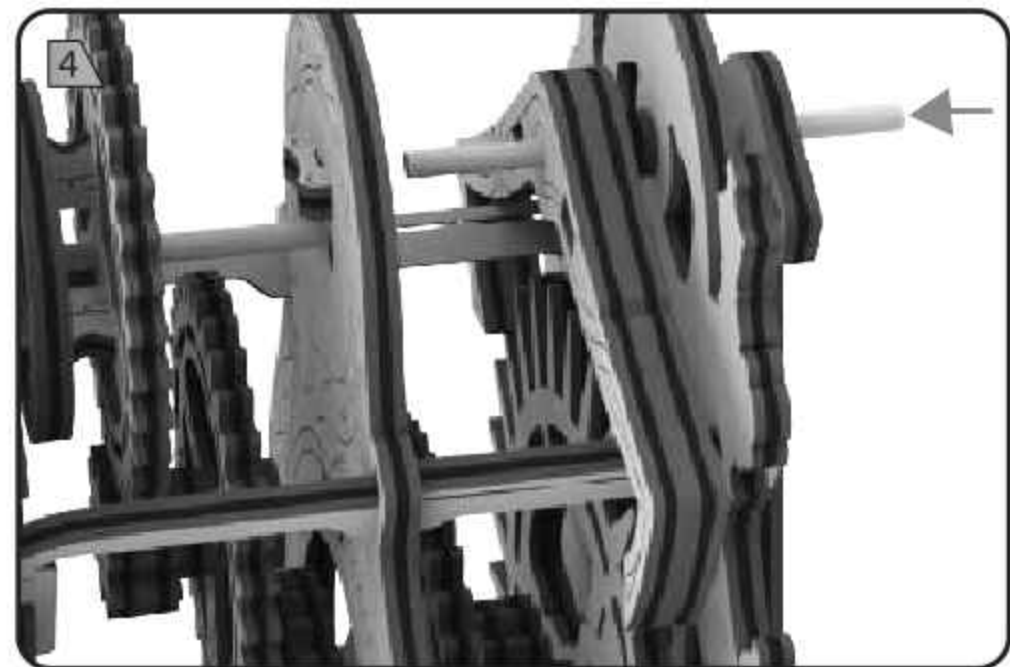
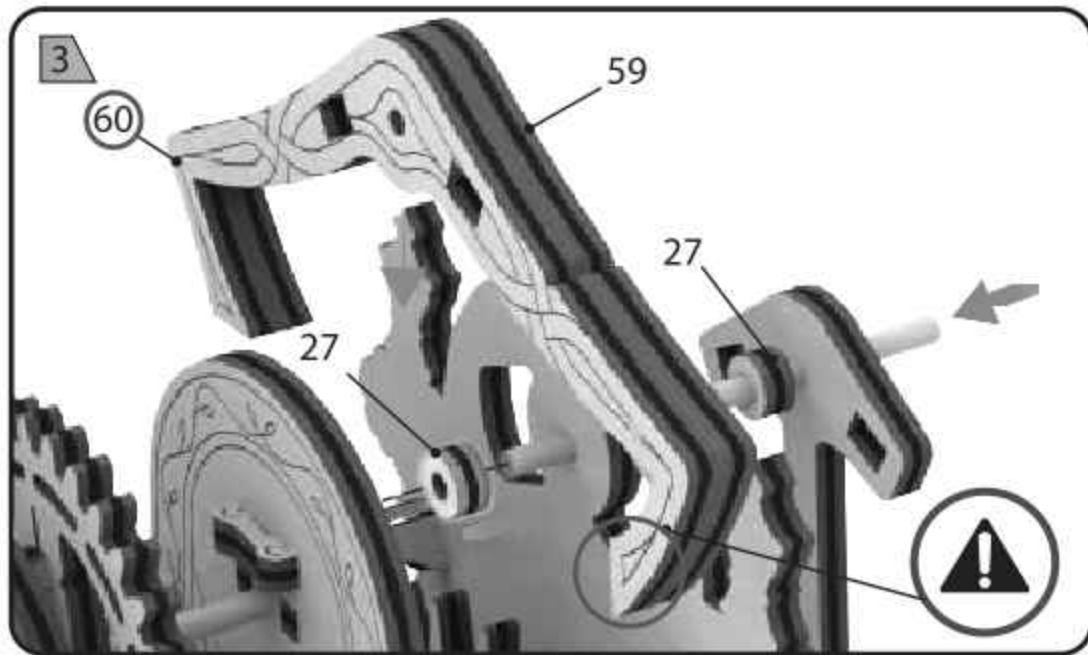



7

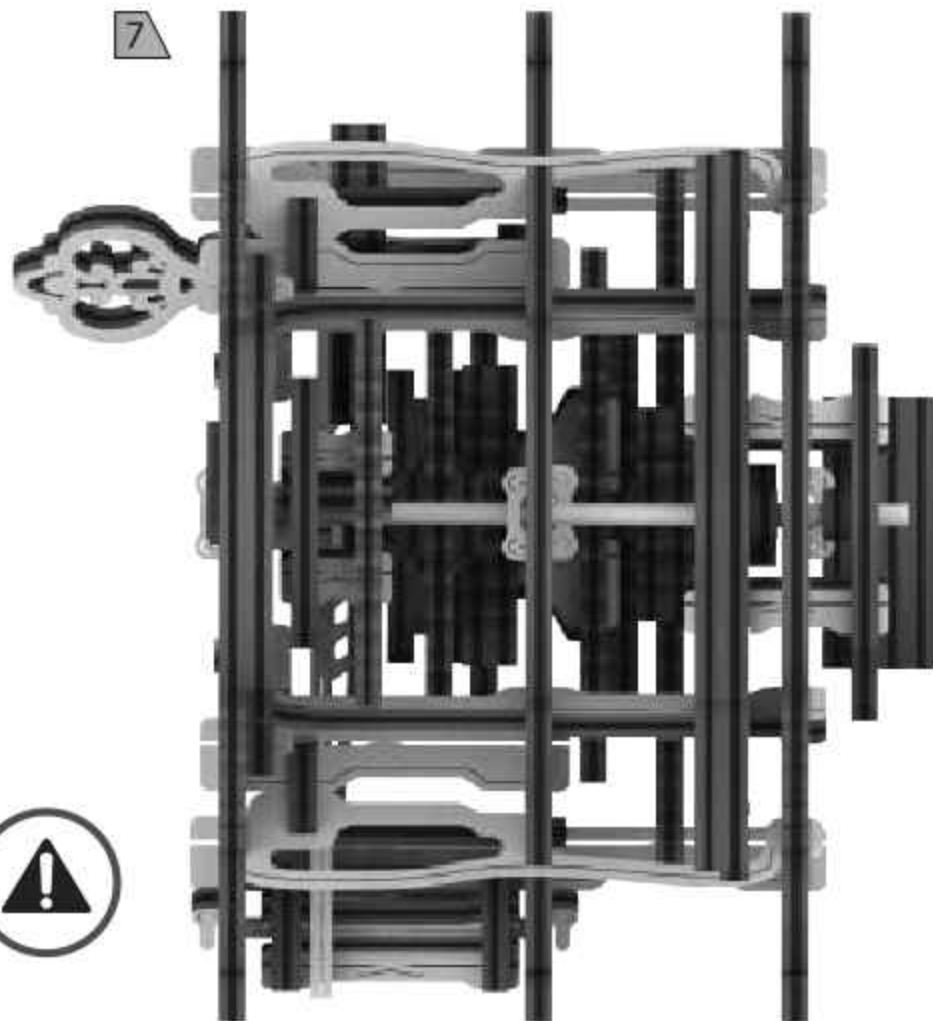

**EN** The clock should be installed on horizontal surface to avoid clogging and blocking of the mechanism.

**FR** L'horloge doit être installée sur une surface horizontale pour éviter le colmatage et blocage du mécanisme.

**ES** Para prevenir atascamiento de mecanismo instale el reloj únicamente en las superficies horizontales planas.

**PL** Aby uniknąć zacinania się mechanizmu, ustawiaj zegar tylko na poziomej powierzchni.

**DE** Die Uhr sollte auf einer horizontalen Fläche platziert werden, um den einwandfreien Lauf des Uhrwerks zu gewährleisten.

**RU** Во избежание заклинивания механизма, устанавливайте часы только на горизонтальной плоскости.

**IT** Per evitare inceppamenti del meccanismo, impostare l'orologio solo sul piano orizzontale.

**CN** 此钟应置于水平表面避免不水平造成机构阻塞和卡死。



$\angle 0^\circ$





**EN** Accuracy of movements is adjusted by the number of coins placed in the lower section of the pendulum. Use several coins of different diameter to adjust the clock in most precise manner.

**FR** La précision des mouvements est ajustée en fonction du nombre de pièces placées dans le bas section du pendule. Utilisez plusieurs pièces de diamètre différent pour ajuster le horloge de la manière la plus précise.

**ES** Precisión de funcionamiento se ajusta con ayuda de monedas que se introducen en el compartimiento situado en la parte inferior del péndulo. Utilice unas cuantas monedas de diferentes diámetros para precisar al máximo funcionamiento del reloj.

**PL** Dokładność biegu należy regulować ilością monet wkładanych w dolną część wahadła, wykorzystaj kilka monet o różnej średnicy aby jak najdokładniej wyregulować bieg zegara.

**DE** Die Genauigkeit der Pendelschläge wird durch die Anzahl und das Gewicht der Münzen im unteren Teil des Pendels eingestellt. Verwenden Sie mehrere Münzen mit unterschiedlichem Durchmesser und Gewicht, um die Uhr präzise einzustellen.

**RU** Точность хода регулируются количеством монет, которые закладываются в нижний отсек маятника. Используйте несколько монет разного диаметра, чтобы как можно точнее отрегулировать ход часов.

**IT** Precisione di funzionamento si regola con la quantità delle monete che vengono inseriti nel vano inferiore del pendolo, utilizzare un paio di monete di diverso diametro per regolare l'orologio meglio.

**CN** 在钟摆下方摆放硬币·通过数量来调整运动的精确性·也可以通过不同大小的硬币来进一步微调钟摆的运动·

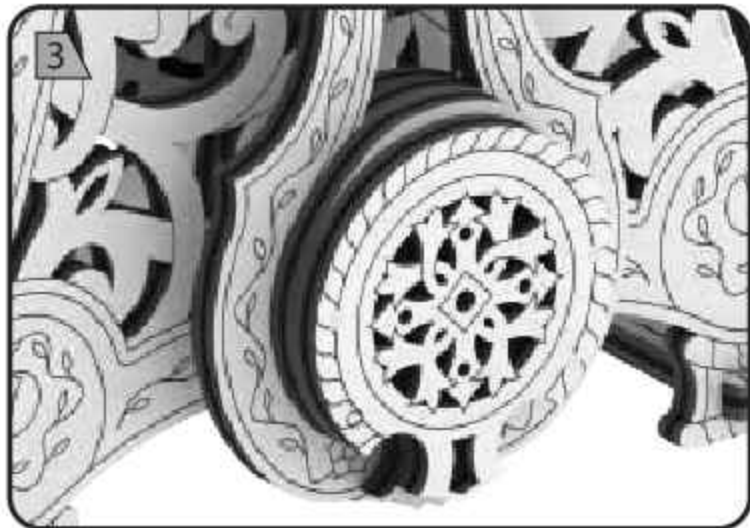
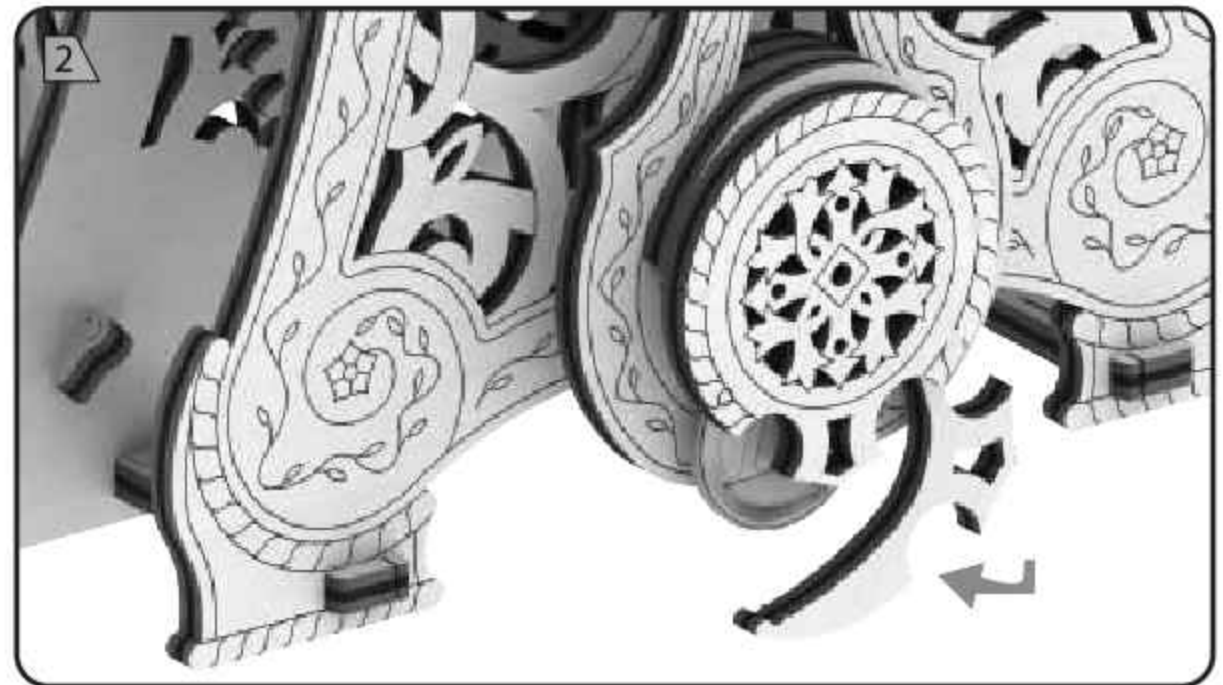

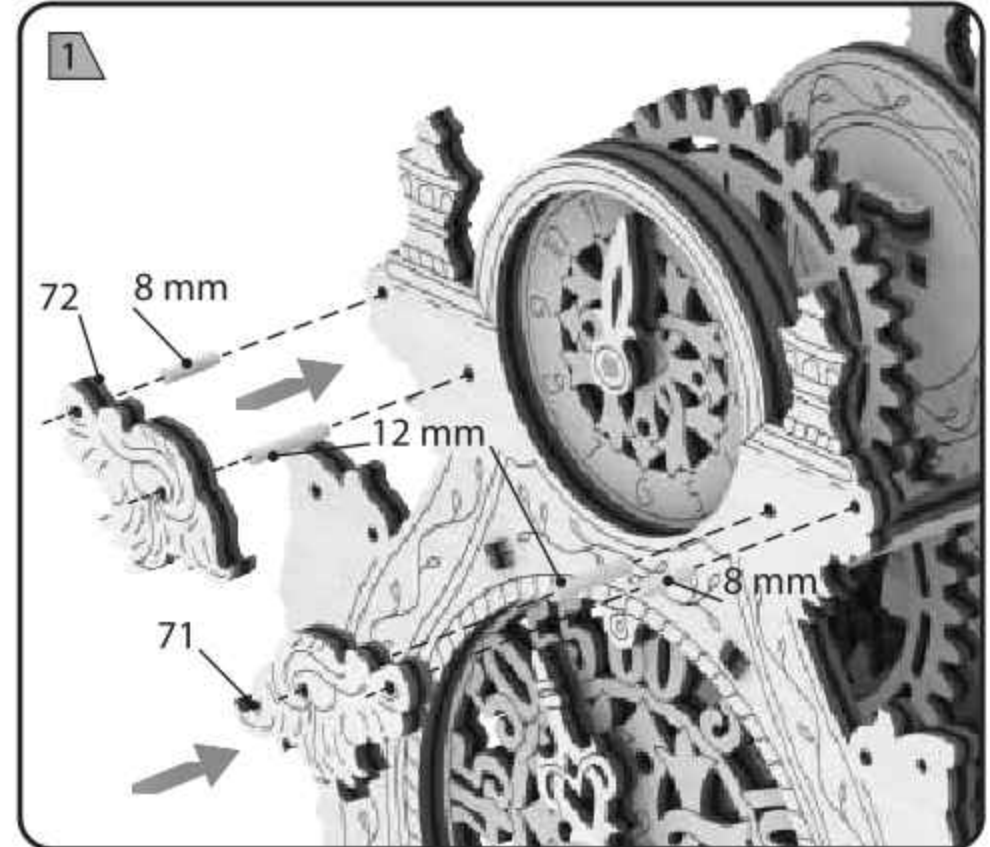
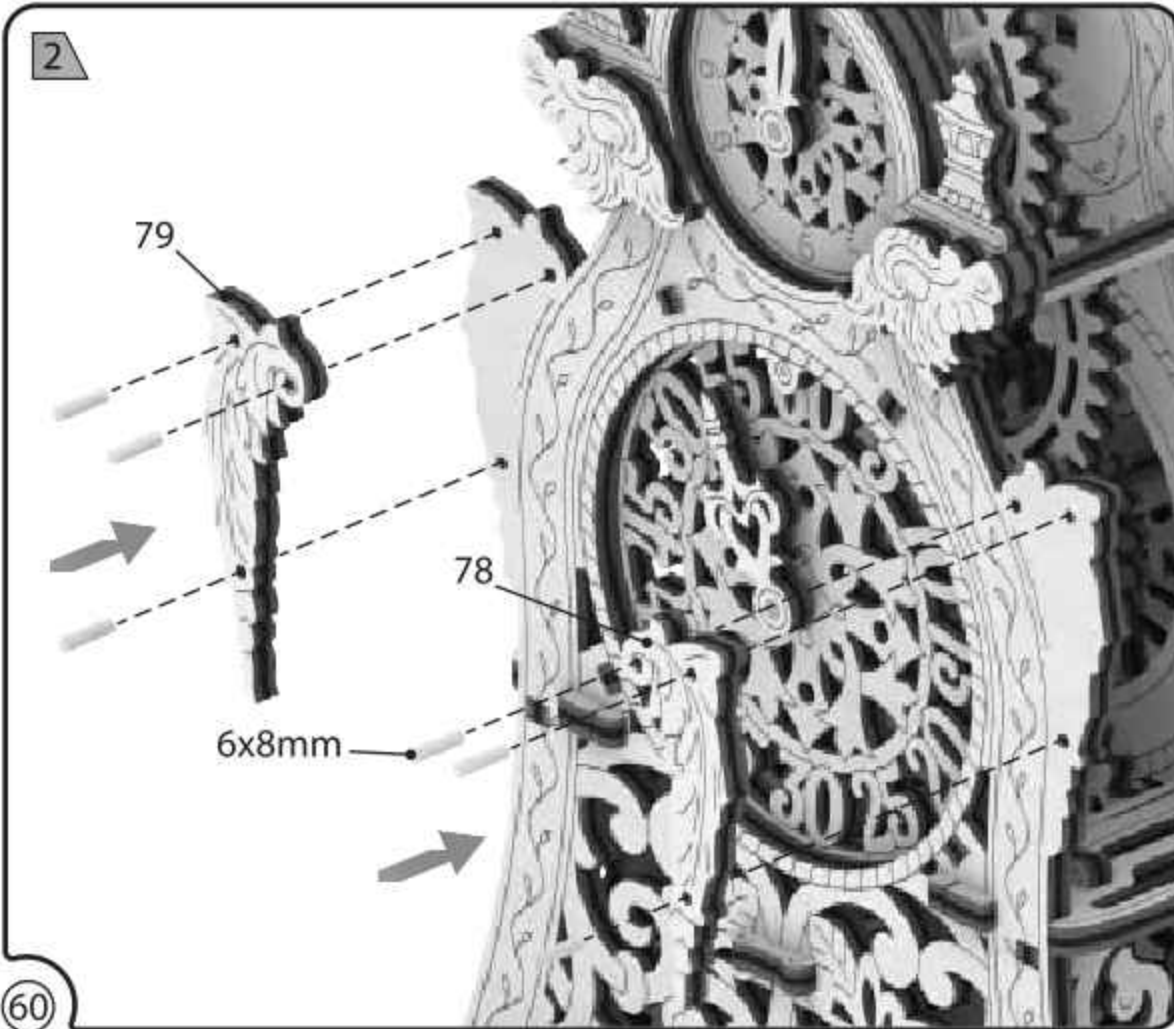
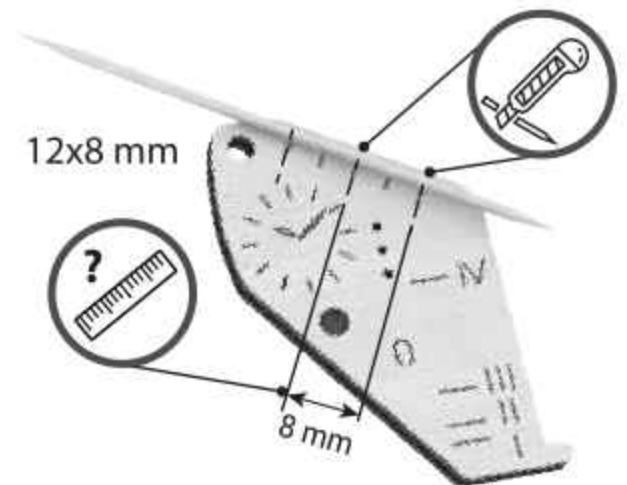
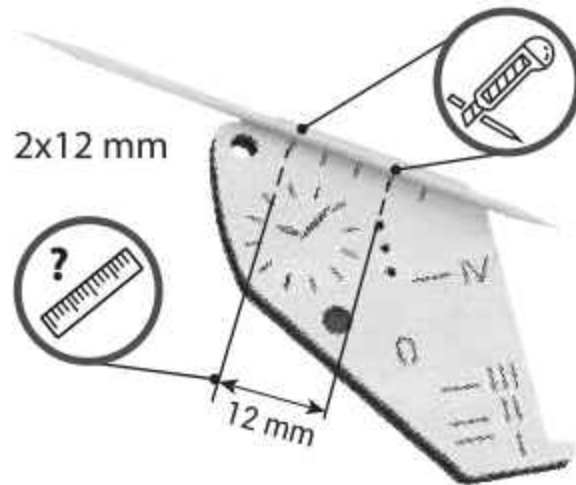
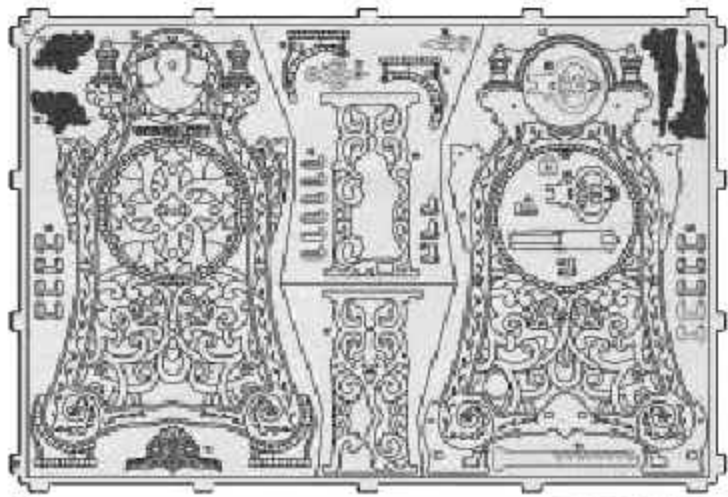

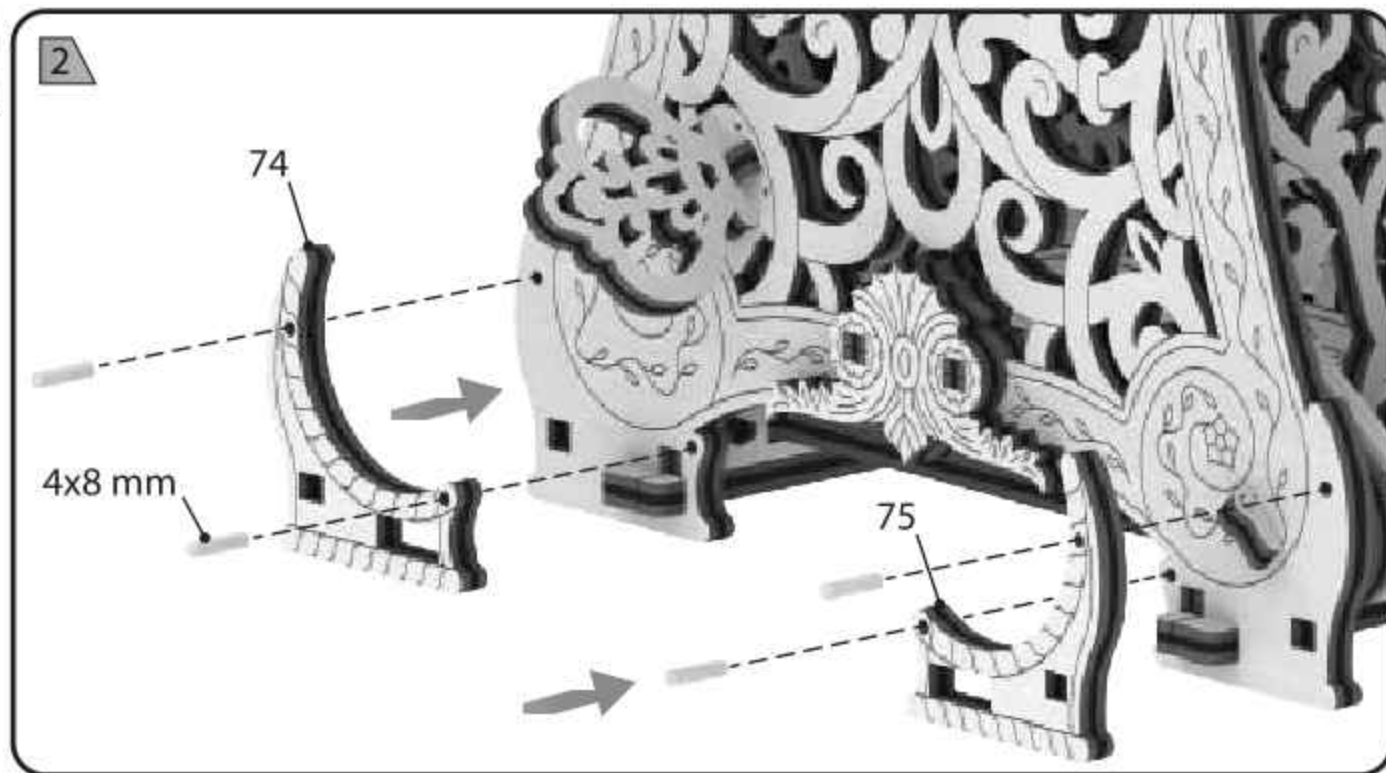
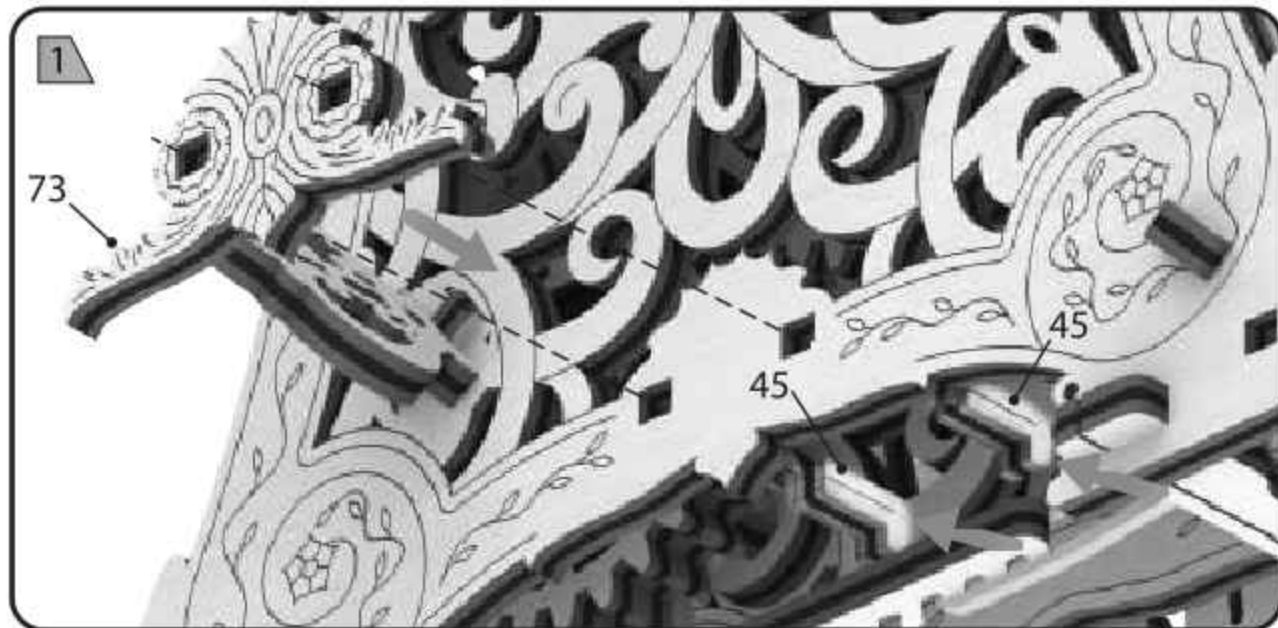
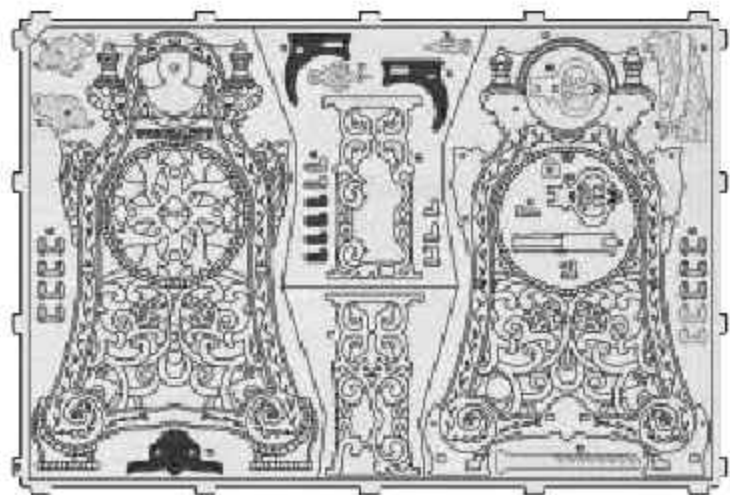
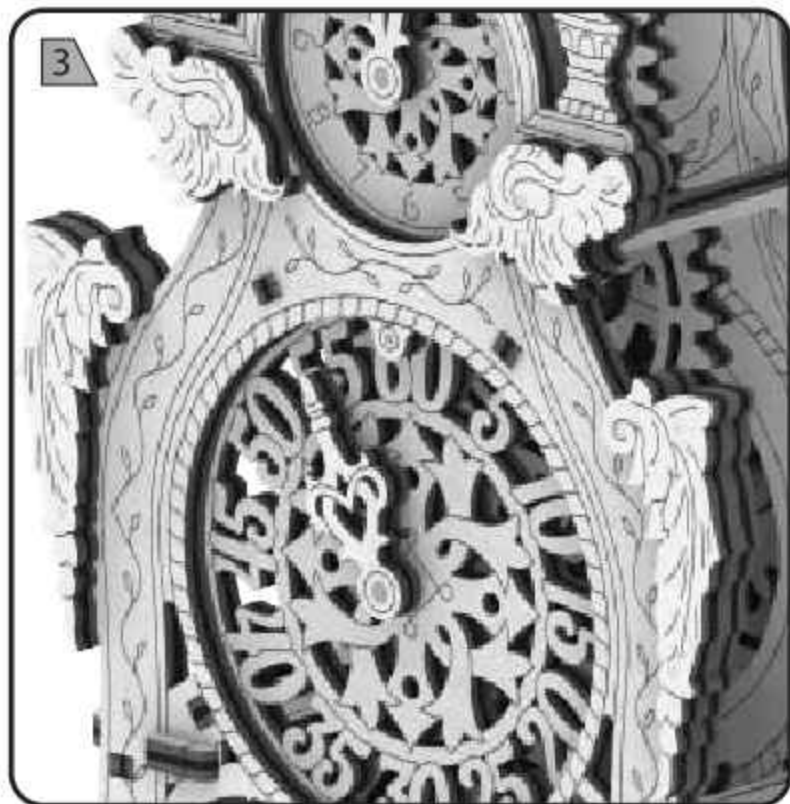



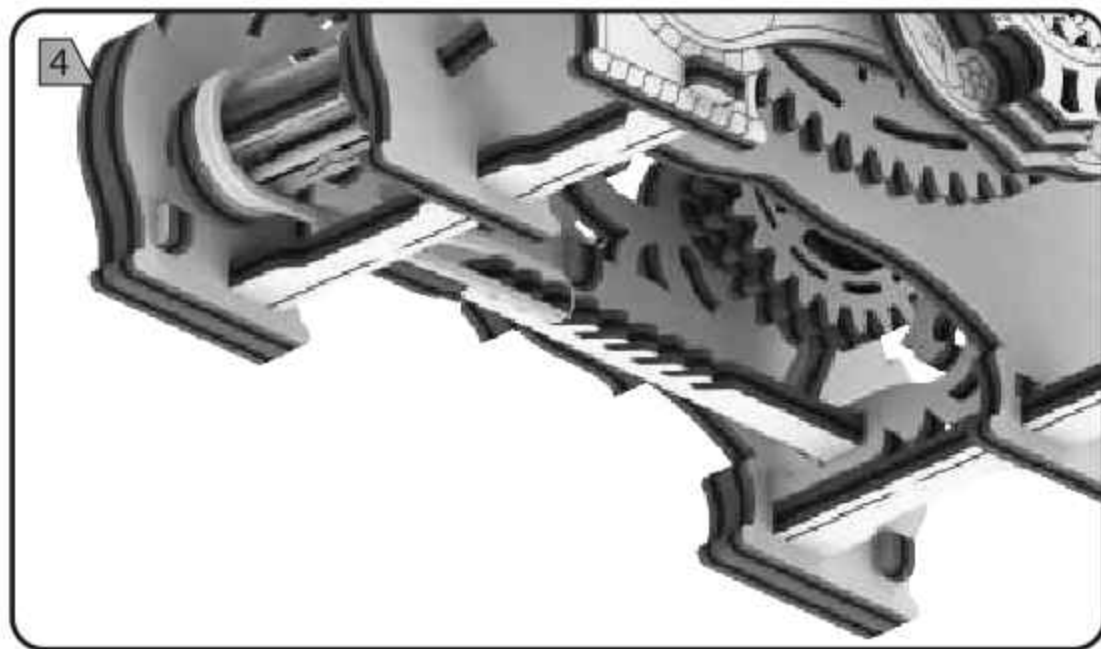
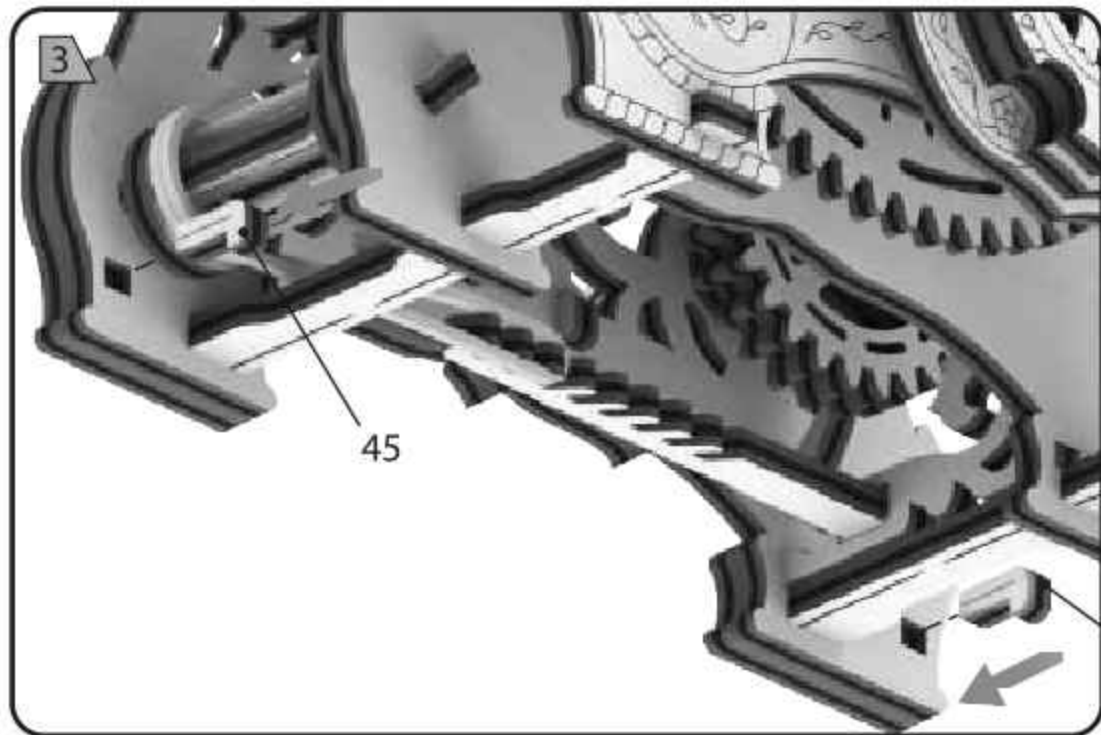

300 min

**EN** Replacing the rubber piece. If the rubber piece of the barrel drum is torn, remove the remnants, take spare rubber piece and proceed as follows:

**FR** Remplacement de la pièce en caoutchouc. Si la pièce en caoutchouc du tambour est déchirée, enlever les restes, prendre un morceau de caoutchouc de rechange et procéder comme suit.

**ES** Reemplazo de banda de caucho. En el caso de ruptura de banda de caucho del barrilete retire sus restos. Después coja una banda de reemplazo y haga siguientes pasos:

**PL** Wymiana gumki. W przypadku, gdy gumka bębna napędowego się podarła, najpierw usuń jej resztki, potem weź zapasową gumkę i wykonaj takie działania:

**DE** Austausch des Gummibandes: Wenn das Gummiband der Trommel gerissen ist, entfernen Sie die Reste, nehmen Sie ein Ersatzgummiband und gehen Sie wie folgt vor:

**RU** Замена резинки. Если резинка заводного барабана порвалась, то сначала удалите ее остатки, а затем возьмите запасную резинку и выполните следующие действия:

**IT** Sostituzione dell'elastico. Se l'elastico del tamburo di avvolgimento si è strappato, prima rimuovere i residui, e poi prendere un elastico di ricambio ed effettuare le seguenti operazioni:

**CN** 更换橡胶件。如果发条鼓的橡胶件磨损，请先将残留物去除，换上备用的橡胶件，请遵照以下流程：

